



# The NSEU Response of Static Latch Based FPGAs

Joseph J Fabula

Austin Lesea

Carl Carmichael

Saar Drimer

*This work has benefited from the use of the Los Alamos Neutron Science Center at the Los Alamos National Laboratory. This facility is funded by the US Department of Energy under Contract W-7405-ENG-36.*

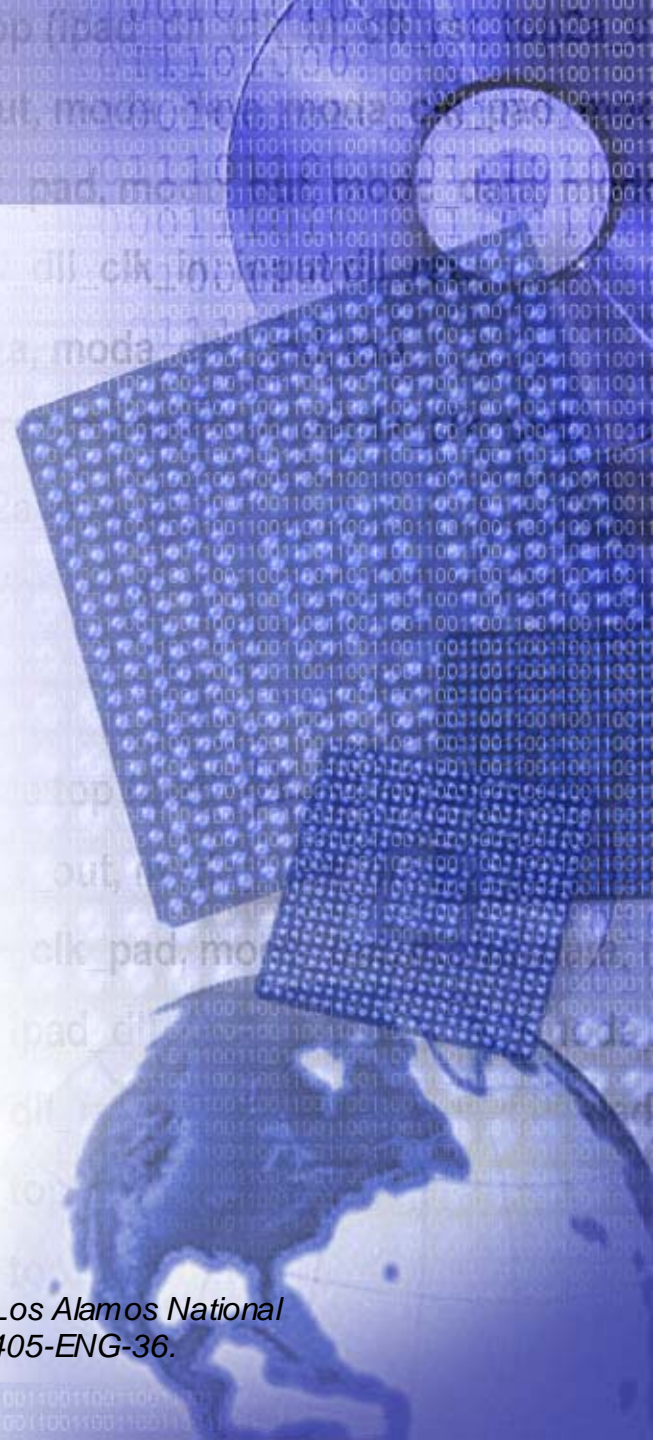

# Where Neutrons Come From

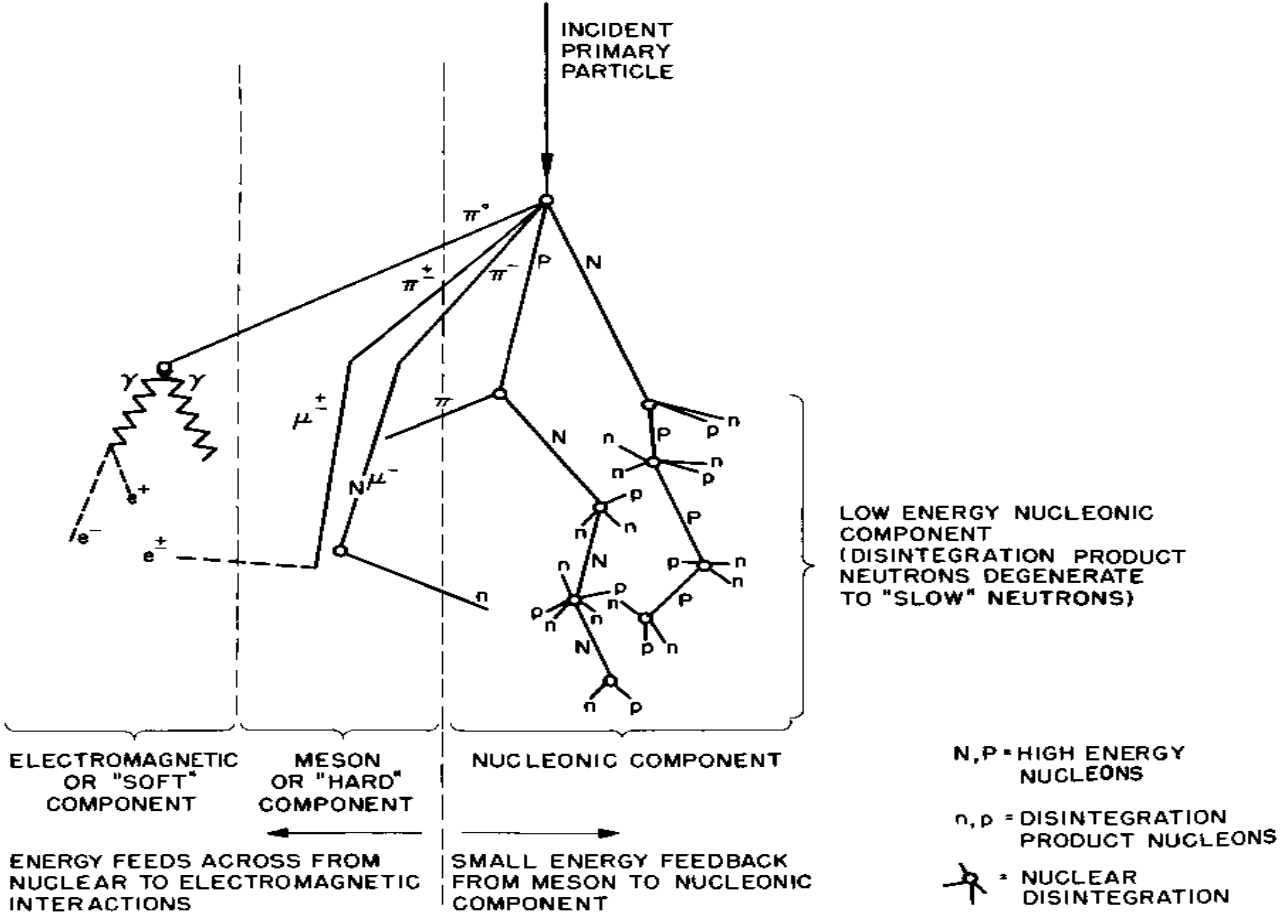

Schematic Diagram of Cosmic Ray Shower



# How Neutrons Can Generate Charged Particles in any IC

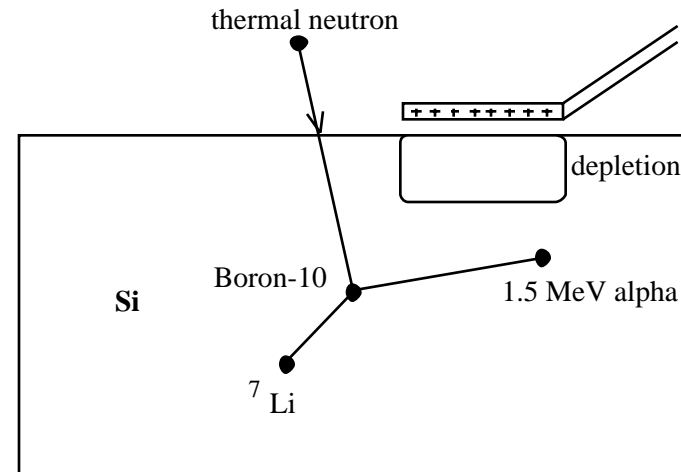
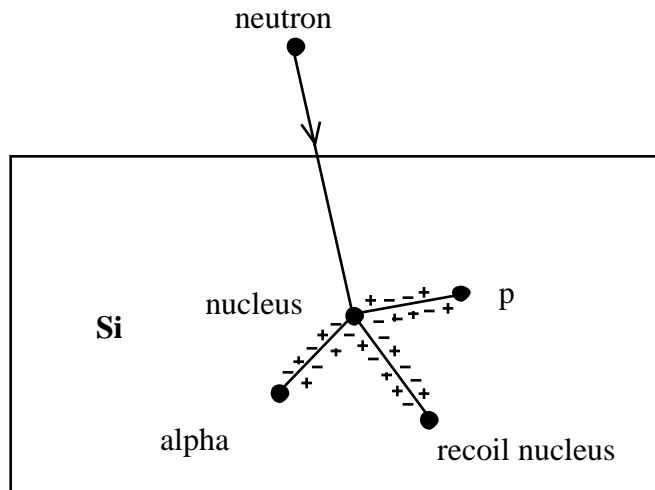

note: These alpha and other charged particles are being generated right in the silicon itself. Unlike packaging induced alphas, they do not have to penetrate the top metalization. They can be generated right where they can do the most harm.

# Single Event Upset (SEU)

*A single high-energy particle can strike a critical node and leave behind an ionized track.  
If the value of this charge is high enough, a voltage of sufficient value can cause a bit flip called soft error.*

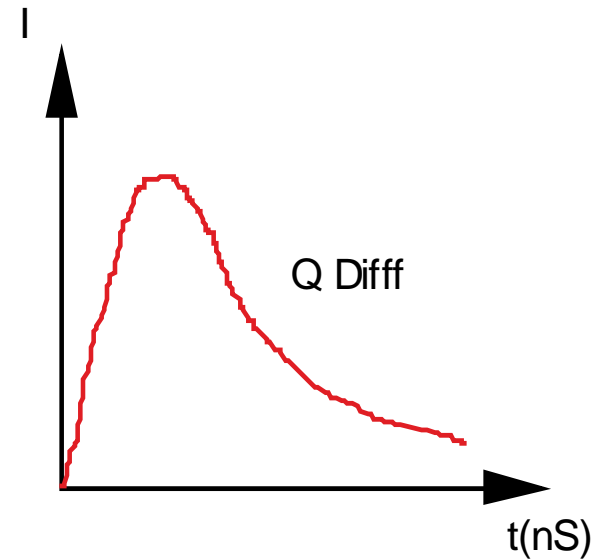
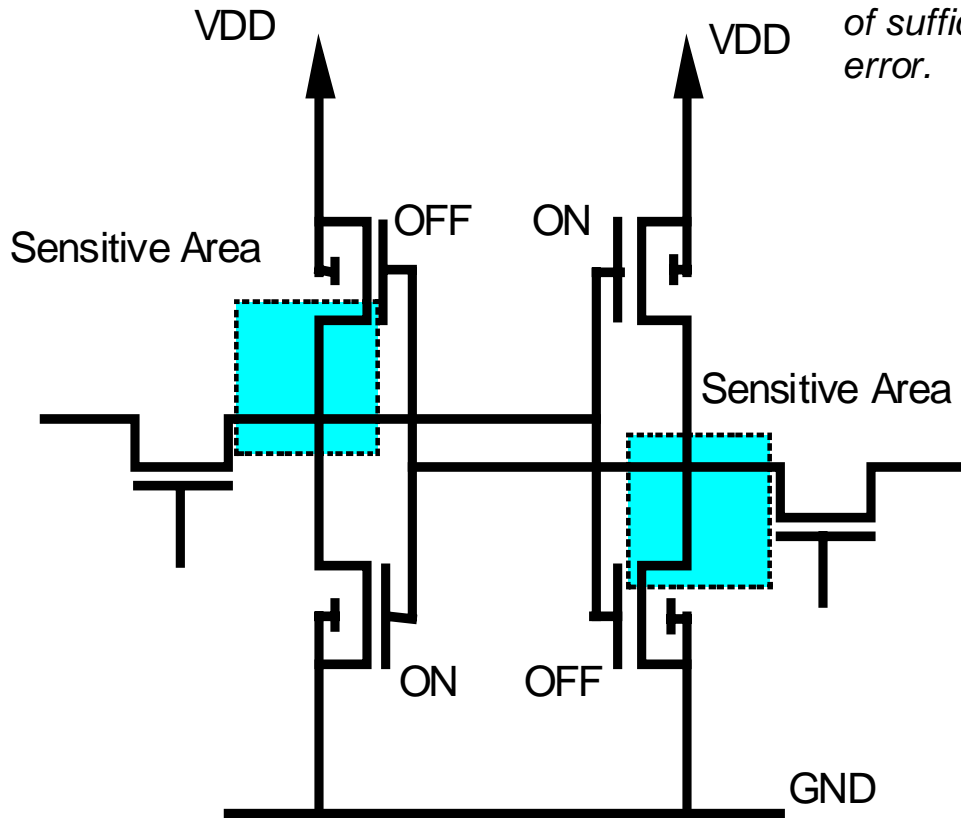

# How Neutron Flux Varies with altitude/with latitude

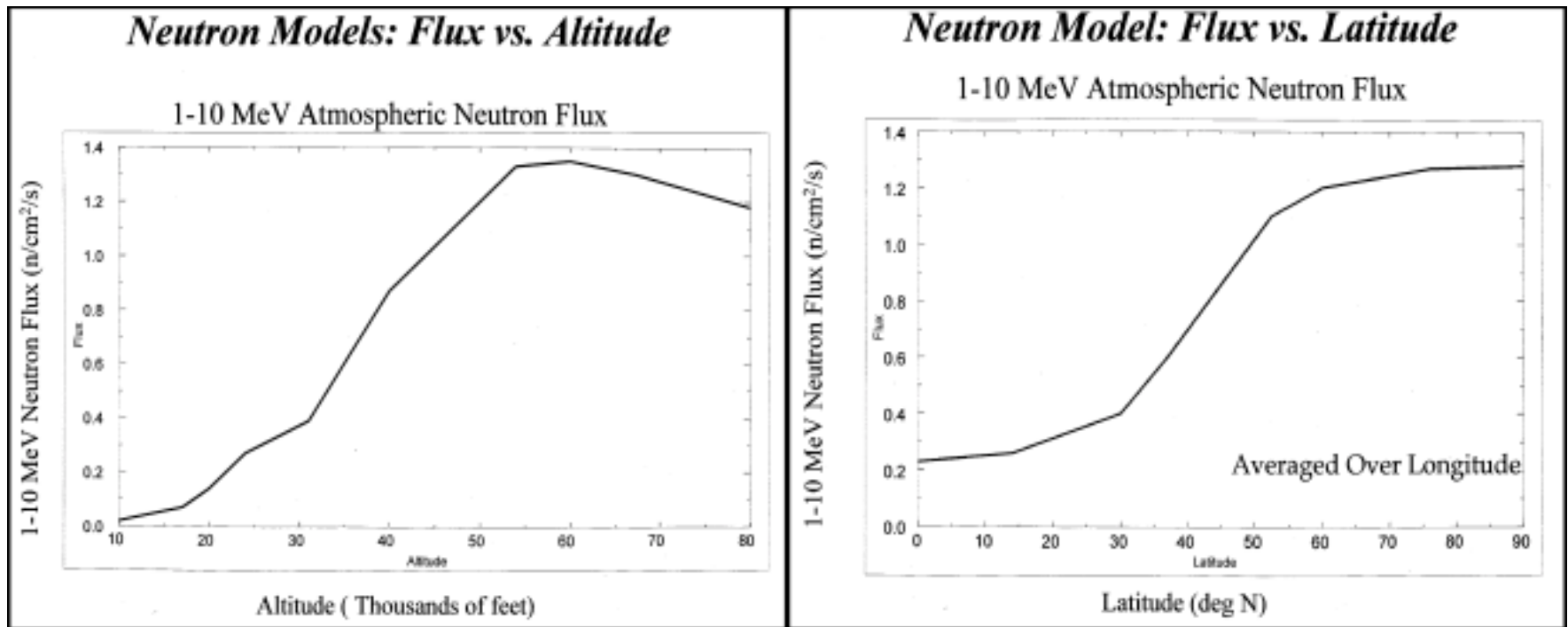

# How we can test for NSEU ?

- For accelerated neutron testing
  - Testing can be done with Protons (sort of)
    - Mass approximates a neutron, charge effects complicate
    - Proton sources are readily available (cheap)
  - Testing with Spallation Neutron sources
    - LANSCE spallation spectrum matches atmospheric neutrons
    - LANSCE source gives ~  $10^5$  to  $10^6$  acceleration
  - Testing in nuclear reactors
    - reactors yield quasi mono-energetic neutron sources
    - calculations back to Hess spectrum are difficult
- For atmospheric (applications) testing
  - We can use the natural radiation environment around us
  - Acceleration is possible only by increasing the altitude of the test
  - Due to low rates, a very large number of devices are required
  - Testing times can be very long (many month to years)
  - Acceleration (up to 10X) is achievable by testing at altitude(s)
  - However, this test is the ultimate correlation for all accelerated tests

# Choice of the LANSCE Source

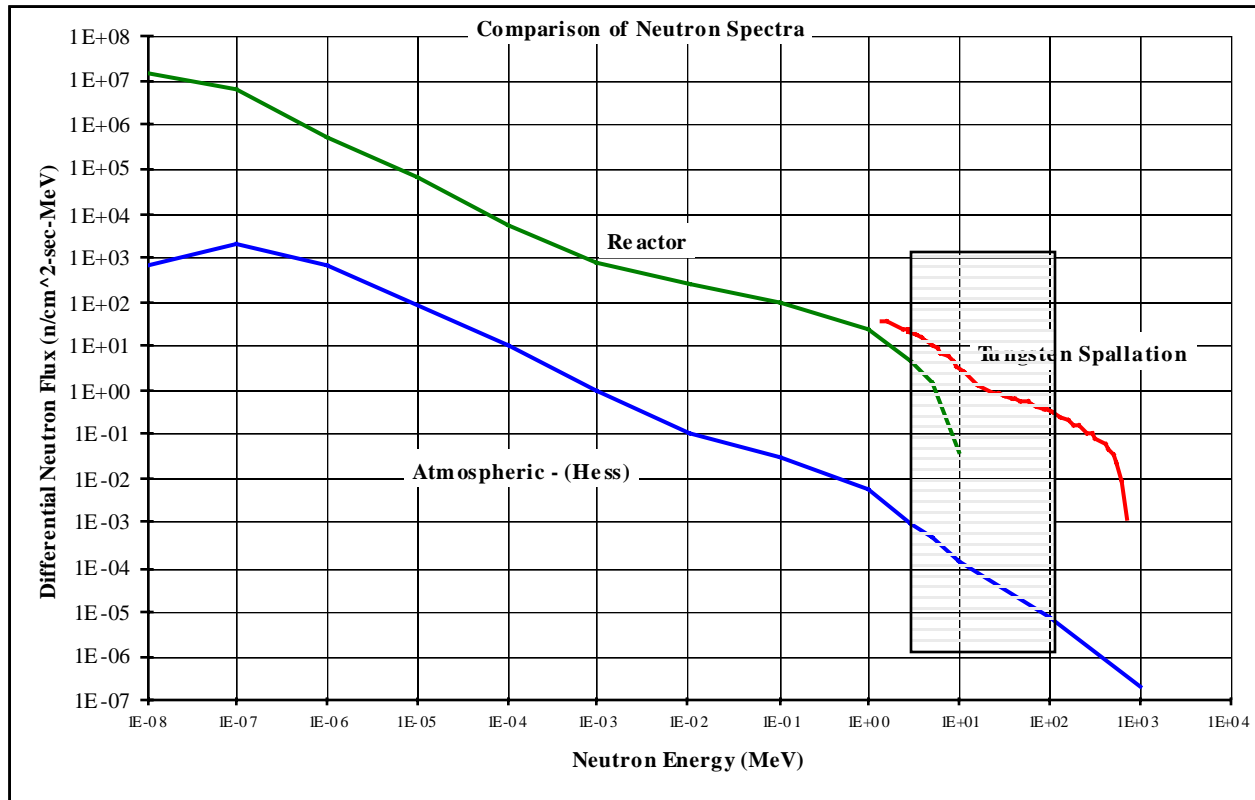

# What NSEU testing was done by Xilinx

- Proton Cross Sections
  - Taken at Crocker (Davis) and Texas A&M
  - Correlation with neutron data was disappointing
- Neutron Cross Sections
  - Taken at the LANSCE facility at Los Alamos
  - Evaluating contribution of energy spectrum models
- Atmospheric Neutron Testing (Rosetta)
  - Utilized a large population of parts
  - Testing was performed at three altitudes
  - Correlated well with some LANSCE results

# Why we did Rosetta ?

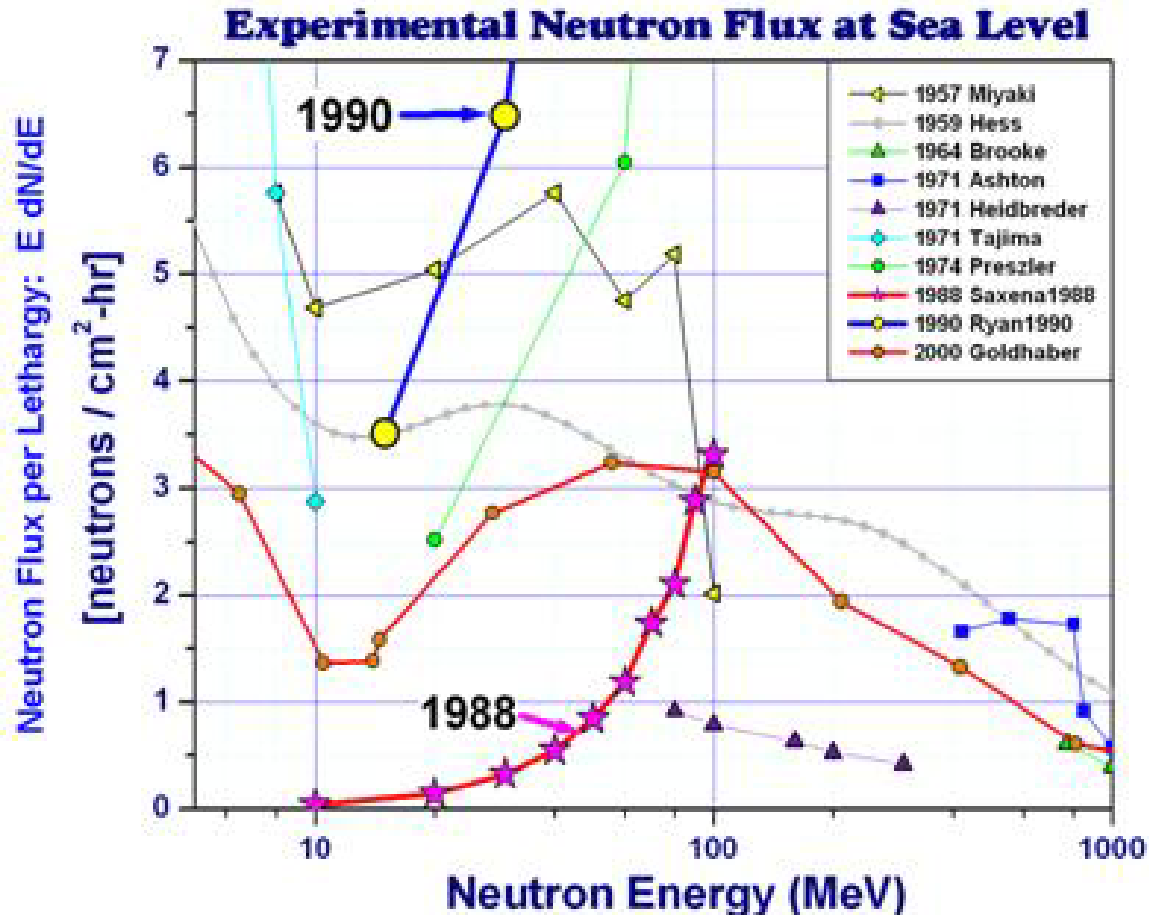

Effects of Terrestrial Cosmic Rays, J.F. Zeigler, United States Airforce Academy.

Neutron Library at Oakridge

<http://www.srim.org/SER/SERTrends.htm>

# Xilinx Rosetta Tests

- Real-life, real-time atmospheric testing
- Used to correlate LANSCE energy models
- Used large boards with 100 XC2V6000s
  - runs 24 hours a day, internet-monitored
  - read back and error logging 12 times a day
  - Each test contains >1.9 terabits of config latch
- Test currently is operational at 3 altitudes
  - At ~Sea level in San Jose
  - At 5,200 feet in Albuquerque
  - At 12,250 feet at White Mountain Research Center

# Rosetta Test Board

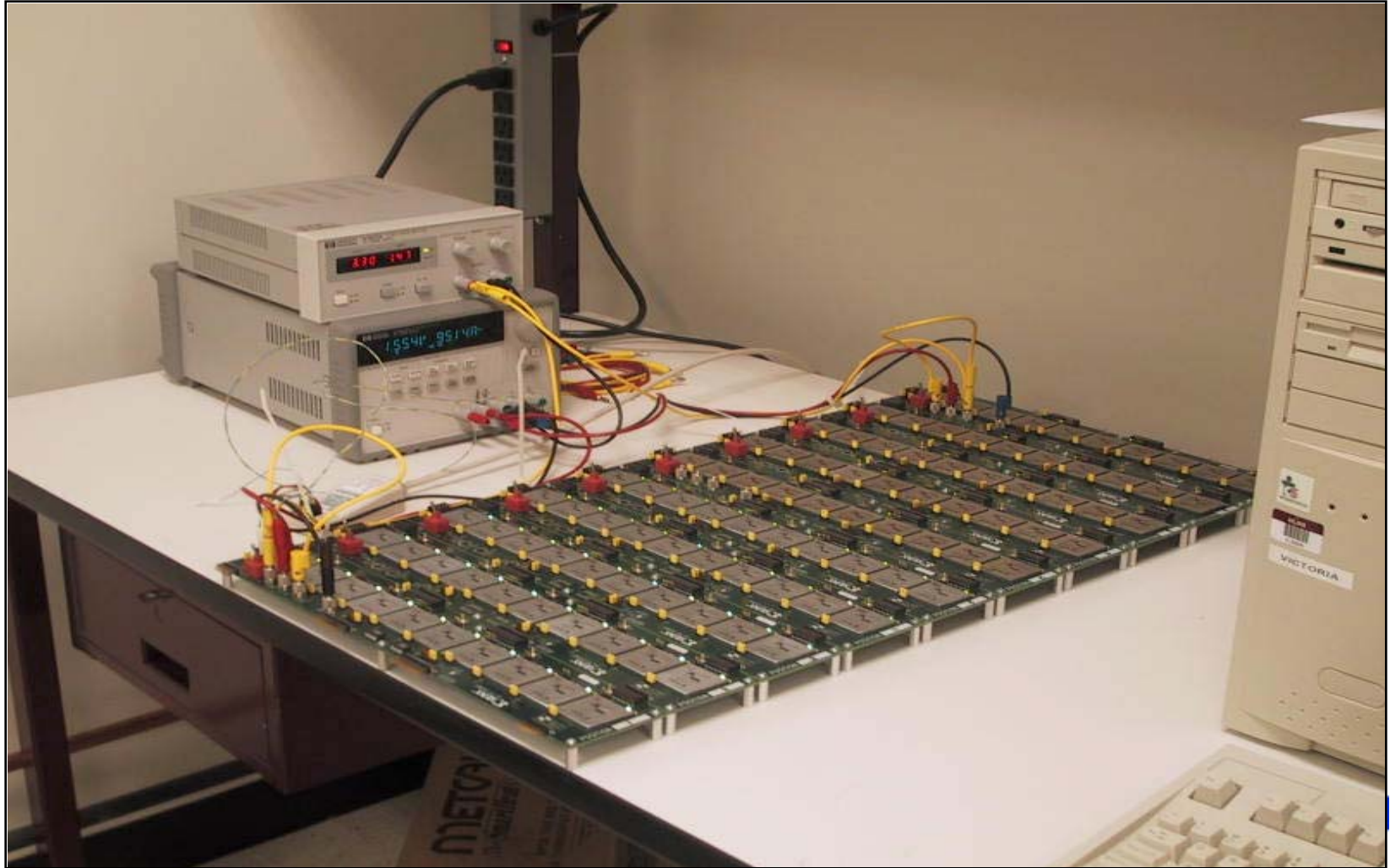

# NSEU Program Flow Chart

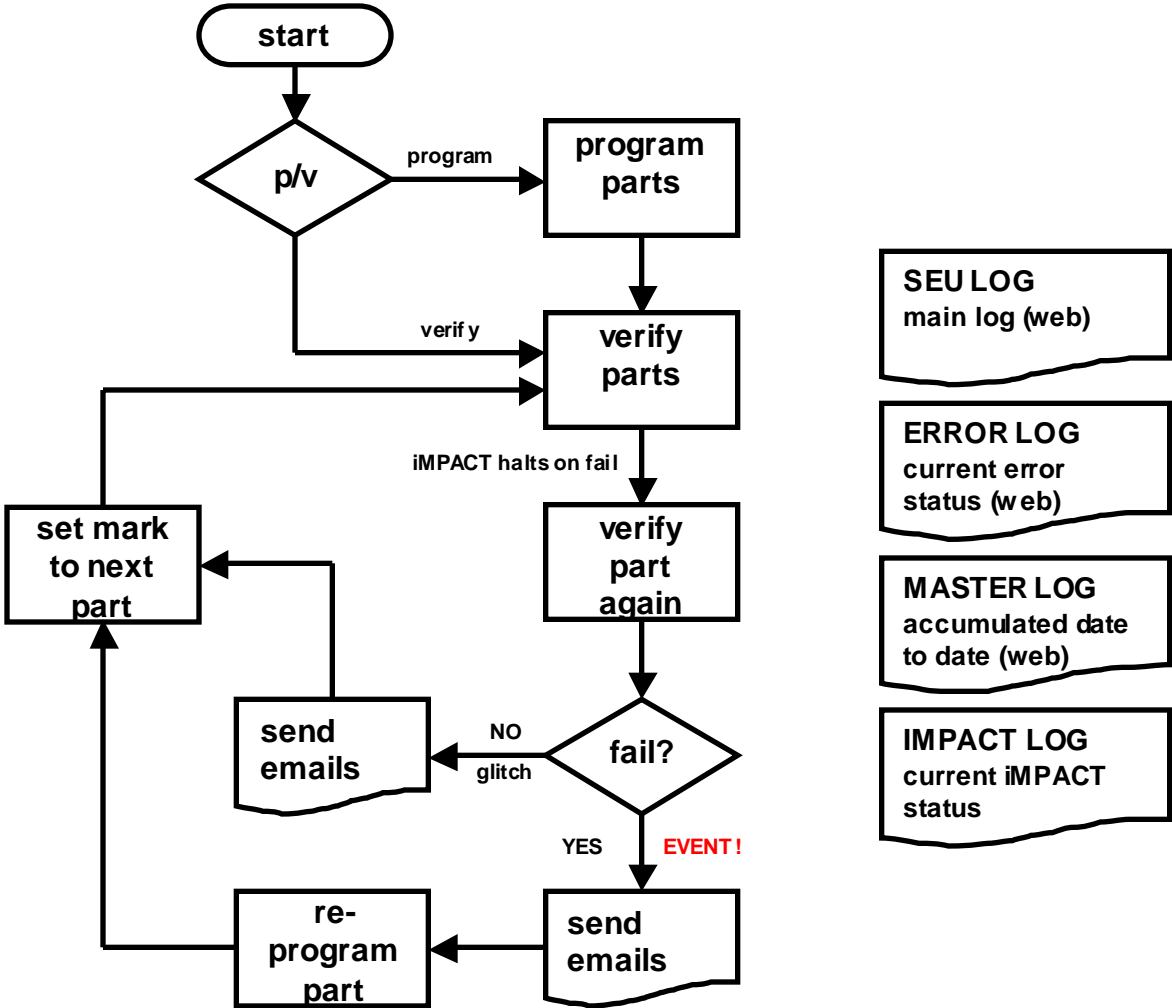

# Comparison of Results at 150 nM

- Proton Cross Section
  - 3.40e-14 cm<sup>2</sup> (10 to 100 MeV)
- Neutron Cross Sections (LANSCE Hess Spectrum)
  - >1.5 MeV 1.80e-14 cm<sup>2</sup>
  - >10.0 MeV 3.43e-14 cm<sup>2</sup>
- Neutron Cross Sections (Rosetta Data)
  - >1.5 MeV 5.29e-15 cm<sup>2</sup>
  - >10.0 MeV 3.17e-14 cm<sup>2</sup>

Voltage	Altitude	Flux Mult	Bits	Hours	>1.5MEV Flux	>1.5MEV Fluence	>10MEV Flux	>10MEV Fluence	Errors	>1.5Mev Cross Section	>10Mev Cross Section
1.5	sea level	1	1958546400	3246	120	389520	20	64920	4	5.243E-15	3.146E-14
1.5	5200	1.67	1958546400	8645	200	1732458	33	288743	18	5.305E-15	3.183E-14
1.5	12250	9.2	1958546400	2084	1104	2300736	184	383456	24	5.326E-15	3.196E-14
							Average Sea Level Cross Section			5.291E-15	3.175E-14

# Particle Cross Sections by Technology

Family	Technology	Proton 10-100 MeV	LANSCE >1.5 MeV	Rosetta >1.5 MeV	LANSCE >10 MeV	Rosetta > 10 MeV
Virtex	220 nM	2.41E-14	5.50E-15	1.65E-15	1.29E-14	1.16E-14
Virtex E	180 nM	3.40E-14	7.69E-15	2.31E-15	1.45E-14	1.31E-14
Virtex II	150 nM	7.48E-14	1.80E-14	5.29E-15	3.43E-14	3.17E-14
Virtex II-Pro	130 nM	5.26E-14	1.56E-14	4.68E-15	3.44E-14	3.10E-14
Spartan 3	90 nM	3.29E-14	1.53E-14	4.59E-15	3.17E-14	2.85E-14

Proton data was taken at Crocker Nuclear Laboratories and Texas A&M  
 Neutron data was taken at the Los Alamos Neutron Science Center  
 Rosetta data was taken at San Jose, Albuquerque and White Mountain

## Neutron Cross Section vs Technology

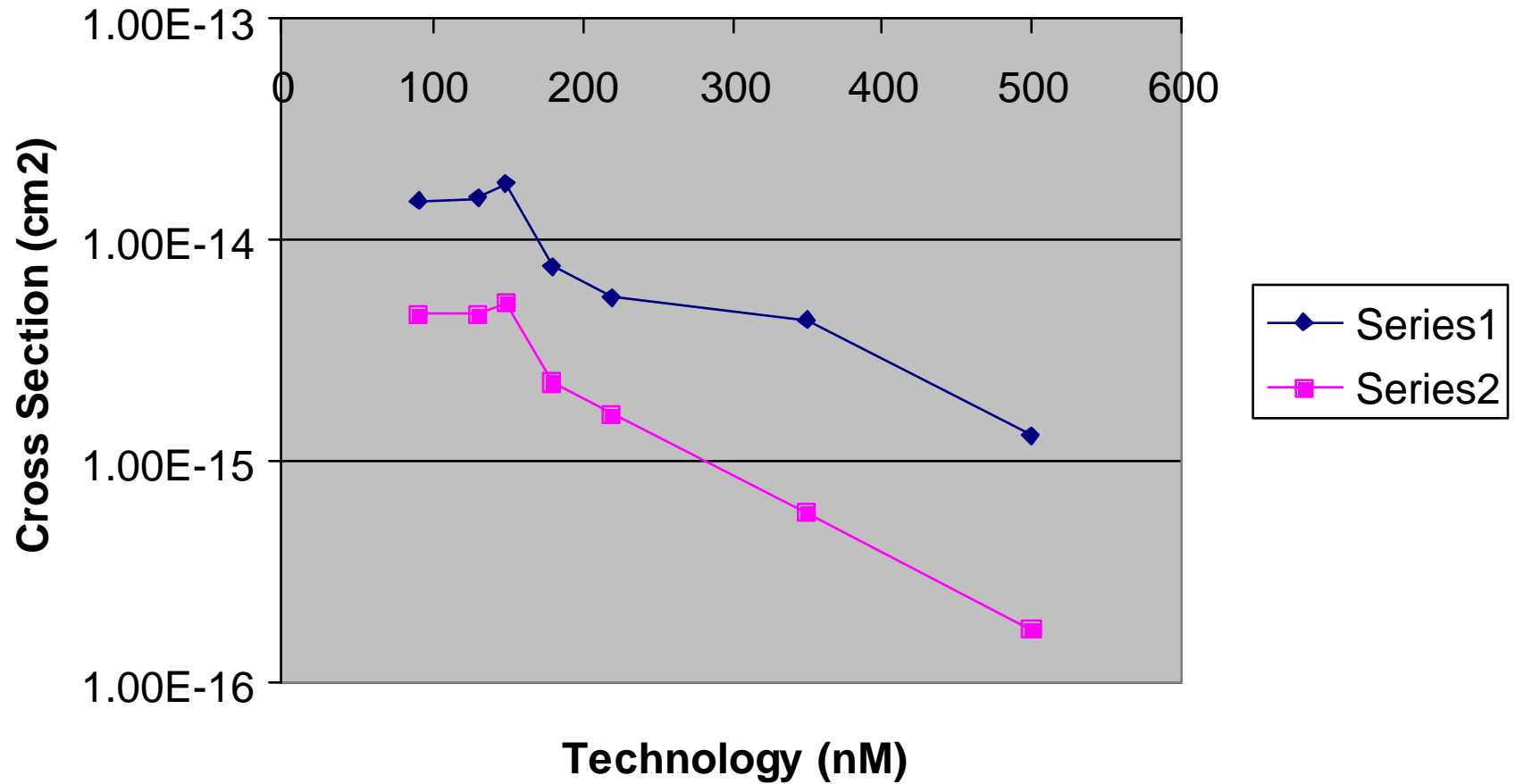

# Configuration Latch Cross Section versus Core Voltage

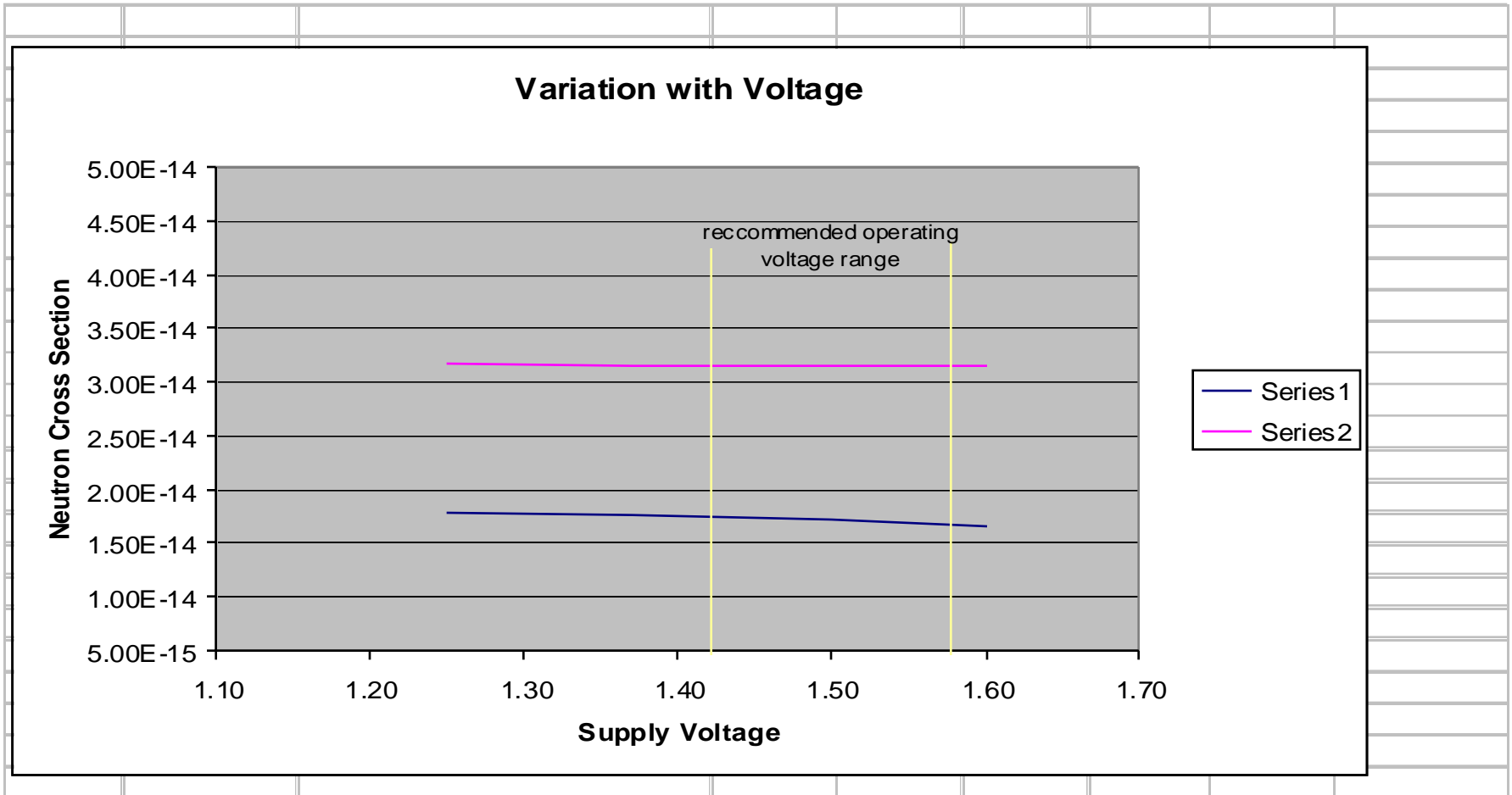

# Neutron Irradiation versus Package Angle Issues

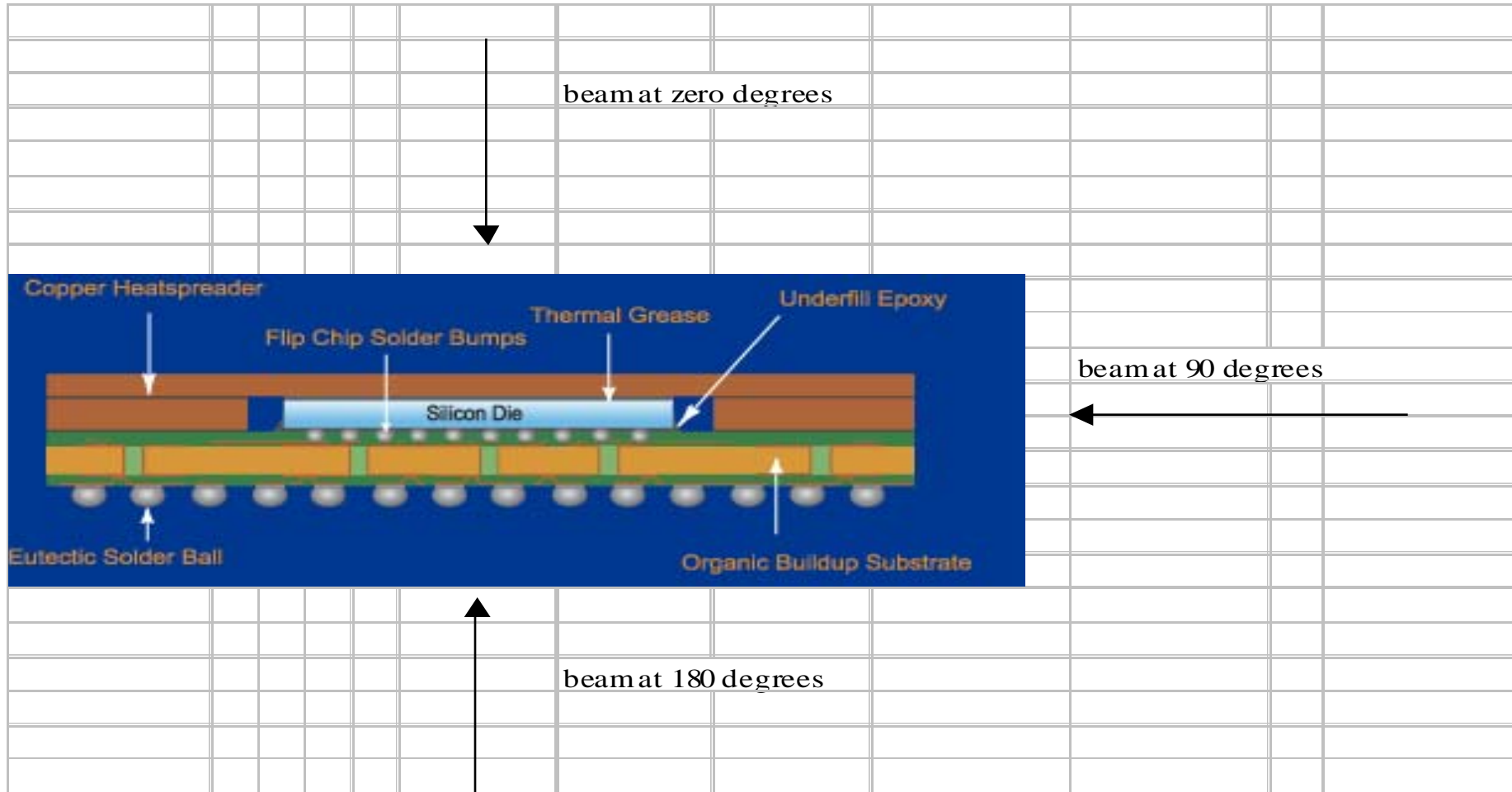

# Neutron Cross Section versus Neutron Beam Incidence

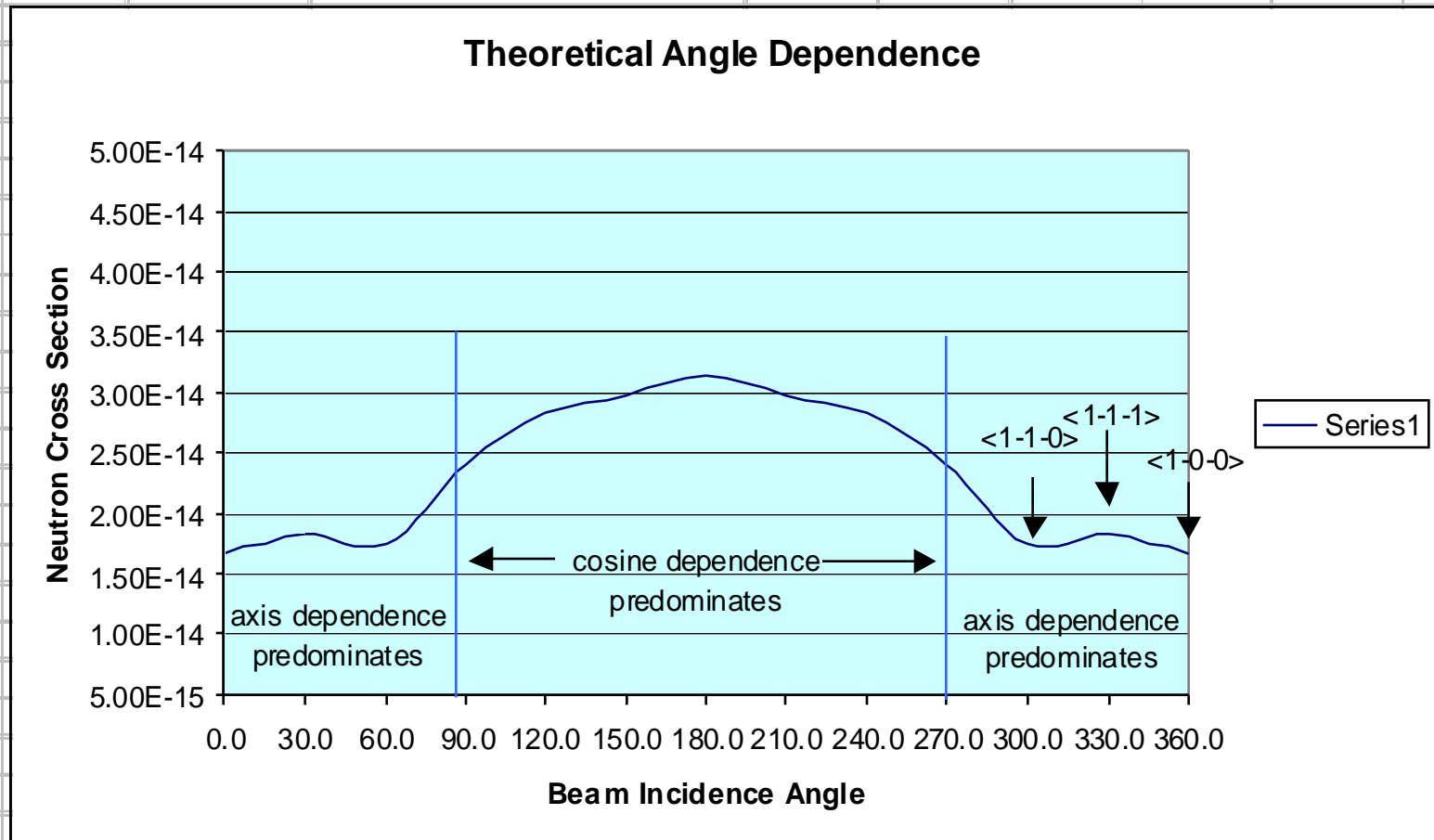

# What's the real Logic MTBF?

- Analysis of many typical designs shows:
  - Only 1 of 10...40 config cells is used
  - 90 to 98% are not used,
  - their SEUs cause no problem whatsoever
- Conservatively we can multiply the MTBF by a factor ten.

# Independent Confirmation

- An early HI experiment by Novus Technologies on the V300 had indicated a logic upset multiplier of between 6 and 40
- Work by BYU and LANL indicated that the logic upset multiplier can be as high as 25 - 100 for specific designs in a V1000
- By logical extension, the larger the FPGA the higher the multiplier for any given logic implementation
- BYU and LANL have developed a bit flip logic impact simulator for the V1000 that has been verified in Proton testing
- Xilinx has extensive data on PIP utilization from the many EasyPath applications that we are supporting
- Xilinx laboratories are developing software algorithms (SEUPI) to identify "critical" bits which may affect user logic

# The Impact of Technology

Device	Technology nM	Config Bits	Neu Sect cm <sup>2</sup>	Rosetta cm <sup>2</sup>	MTTE hours	MTBF years
<b>Calculations based on "&gt;1.5 MEV" model for neutron flux, Rosetta factor = 4.10</b>						
XCV1000	220 nM	5.10E+06	5.50E-15	1.34E-15	1.22E+07	1390
XCV1000E	180 nM	5.90E+06	7.69E-15	1.88E-15	7.53E+06	860
XC2V1000	150 nM	2.57E+06	1.80E-14	4.39E-15	7.39E+06	843
XC2VP4	130 nM	3.00E+06	1.56E-14	3.80E-15	7.30E+06	833
XC3S1000	90 nM	1.70E+06	1.56E-14	3.80E-15	1.29E+07	1471
<b>Calculations based on "&gt;10.0 MEV" model for neutron flux, Rosetta factor = 1.08</b>						
XCV1000	220 nM	5.10E+06	1.29E-14	1.19E-14	8.21E+06	937
XCV1000E	180 nM	5.90E+06	1.45E-14	1.34E-14	6.31E+06	721
XC2V1000	150 nM	2.57E+06	3.43E-14	3.18E-14	6.13E+06	699
XC2VP4	130 nM	3.00E+06	3.44E-14	3.19E-14	5.23E+06	597
XC3S1000	90 nM	1.70E+06	3.17E-14	2.94E-14	1.00E+07	1144



# The Impact of Altitude

Device	Technology nM	Config Bits	Neu Sect cm <sup>2</sup>	Rosetta cm <sup>2</sup>	MTBF yrs sea level	MTBF yrs 10,000 ft	MTBF yrs 40,000 ft
<b>Calculations based on "&gt;1.5 MEV" model for neutron flux, Rosetta factor = 4.10</b>							
XCV1000	220 nM	5.10E+06	5.50E-15	1.34E-15	1390	139	24
XCV1000E	180 nM	5.90E+06	7.69E-15	1.88E-15	860	86	15
XC2V1000	150 nM	2.57E+06	1.80E-14	4.39E-15	843	84	15
XC2VP4	130 nM	3.00E+06	1.56E-14	3.80E-15	833	83	15
XC3S1000	90 nM	1.70E+06	1.56E-14	3.80E-15	1471	147	26
<b>Calculations based on "&gt;10.0 MEV" model for neutron flux, Rosetta factor = 1.08</b>							
XCV1000	220 nM	5.10E+06	1.29E-14	1.19E-14	937	94	16
XCV1000E	180 nM	5.90E+06	1.45E-14	1.34E-14	721	72	13
XC2V1000	150 nM	2.57E+06	3.43E-14	3.18E-14	699	70	12
XC2VP4	130 nM	3.00E+06	3.44E-14	3.19E-14	597	60	10
XC3S1000	90 nM	1.70E+06	3.17E-14	2.94E-14	1144	114	20



# Conclusions

- Proton measurements should be used only as a qualitative indicator of NSEU rates
- LANSCE data can provide a good match to atmospheric testing with the correct energy model
- ROSETTA data indicates clear support for using the  $>10.0$  MeV model for current process technology
- The sky is not falling as technology continues to shrink below 220 nM (Moore's law still lives)
- The neutron cross section can be stabilized as technology shrinks (compensating a sensitivity increase by a probability decrease function)
- Designers can and are increasing the robustness of state of the art latches to NSEU effects