



M1535D+ South Bridge

Product Brief

For Multimedia Desktop PCs

Introduction

The M1535D+ provides the best desktop system solution. The M1535D+ integrates AC-Link Host Controller, Hardware SoundBlaster Pro/16 compatibility, Host Signal Processing (HSP) software modem solution, ACPI support, green function, 2-channel dedicated UDMA/ATA-100 IDE Master controller, 2 USB controllers, SMBus controller, PS/2 Keyboard/Mouse controller, the Super I/O (Floppy Disk Controller, 2 serial port/1 parallel port) support and Fast IR into one chip.

The built-in I/O in M1535D+ is an advanced Super I/O controller containing all of the basic IBM PC, XT, AT peripherals. It incorporates three full function universal asynchronous receiver/transmitters (UARTs), a flexible high performance internal data separator with send/receive 16 byte FIFOs. It is also suitable for notebook computers since it has Fast Infra Red for wireless communications with other devices. It can swap the floppy drives A & B. It supports SPP, PS/2, EPP and ECP parallel port. It also has a programmable baud rate generator. It has high performance power management for the FDC, UART and parallel port.

The built-in audio in M1535D+ is an advanced PCI audio accelerator providing wave table synthesis, DirectMusic, DirectSound, and DirectSound3D for the high performance, cost-sensitive consumer market. It also supports full Sound Blaster compatibility and is fully PC'98/PC'99 compliant. The M1535D+ Audio, combined with a standard AC'97/AC'98 Codec, provides better than CD quality audio with sound-to-noise ratio of > 90 db, up to 48 KHz sample rate, full duplex audio with independent playback and recording sample rate, 6-channel mixer and optional 3D surround sound enhanced output. In the legacy DOS game environment, the M1535D+ audio accelerator provides SoundBlaster Pro/16 compatibility, OPL2 and OPL3 emulation, and 1 to 8 MB of general MIDI music through the MPU 401 compatible interface. With built-in support of the legacy mode analog game port, the M1535D+ audio can replace all the functions of a wave table based legacy audio ISA card. In addition, the M1535D+ supports consumer audio digital interface (SPDIF) to connect external digital audio equipment.

The M1535D+ will provide the AC'97 2.1 compliant digital controller interface for third parties (such as the AMC Codec's vendor) to enable the software modem solution. The M1535D+ provides 4 separate telephony bus master channels. One for modem output, one for modem input, one for handset input, and one for handset output. The M1535D+ supports the Modem on-demand variable sample rate transfer, power management, wake-up, and caller ID string transmission.

The M1535D+ will support the security feature such as the platform firmware protection. The M1535D+ also provides the ability to meet the Legacy-Free and Legacy Reduction specification of PC2001.

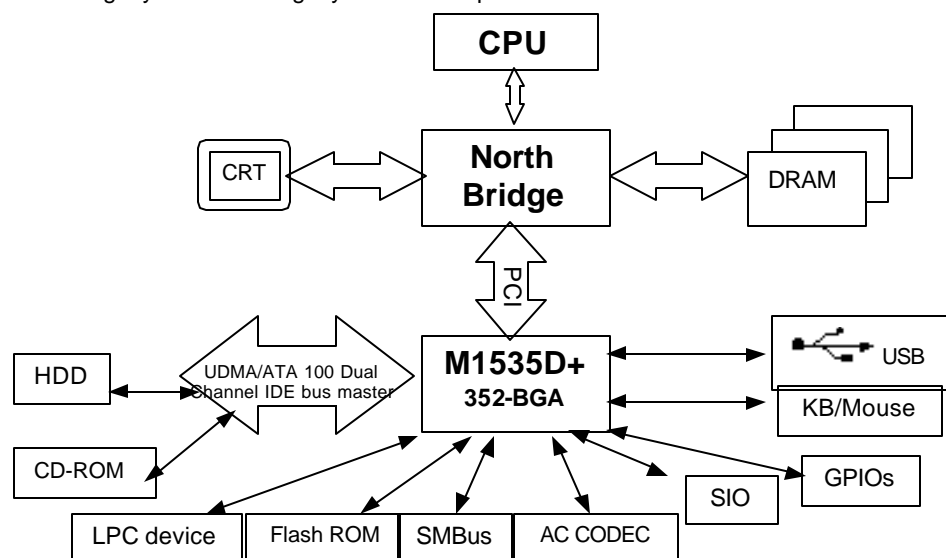

Features

- **Provides a High Integration Bridge (with Audio, HSP Modem, Super I/O & Fast IR) between the PCI Bus and Peripheral Bus for both Desktop and Notebook Systems**

PCI 3.3V/5V Tolerance Interface

- Supports PCI Master and Slave Interface
- Supports PCI Master and Slave Initiated Termination
- Concurrent PCI Architecture
 - PCI spec. 2.2 Compliant
 - PCI Power Management Interface spec. 1.1 Compliant

Provides Steerable PCI Interrupts for PCI Device Plug-and-Play

- Up to 8 PCI Interrupts Routing
- Level to Edge Trigger Transfer

Enhanced DMA Controller

- Provides 7 Programmable Channels, 4 for 8-bit Data Size, 3 for 16-bit Data Size
- 32-bit Addressability

Interrupt Controller

- Provides 14 Interrupt Channels
- Independent Programmable Level/Edge Triggered Channels

Counter/Timers

- Provides 8254 Compatible Timers for System Timer, Refresh Request, Speaker Output Use

Distributed DMA Supported

- 7 DMA Channels can be Arbitrarily Programmed as Distributed Channels

PC/PCI DMA Supported

- 1 PC/PCI DMA Channel Interface Provided

Serialized IRQ Supported

- Quiet/Continuous Mode
- Programmable (Default 21) IRQ/DATA Frames
- Programmable START Frame Pulse Width

Low Pin Count (LPC) Host Controller

- Provides Low Pin Count Host Controller based on Low Pin Count Interface Spec. 1.0

Plug-and-Play Supported

- 2 Programmable Chip Select lines
- 2 Steerable Interrupt Request lines

Built-in Keyboard Controller

- Built-in PS2/AT Keyboard and PS2 Mouse Controller

- **Supports up to 512 KB ROM Size Decoding**

PMU Features

- Full Support for ACPI and OS Directed Power Management to meet system requirement of PC98/PC99
- Full Support for Instantly Available PC feature
- CPU SMM Legacy Mode and SMI Feature Supported
- Full Support for Clock Control Functions of both Pentium and Pentium II CPUs.
- Supports I/O Trap for I/O Restart Feature

PMU Operation States :

1. G0 State
 - On
 - Standby Mode
 2. G1 State (Suspend Mode 1)
 - S1 State (Power On Suspend)
 - S3 State (Suspend To RAM)
 - S4 State (Suspend To DISK)
 3. G2 State (Suspend Mode 2)
 - S5 State (Soft-Off)
 4. G3 State (Mechanical-Off)
- APM State Detection and Control Logic Supported
- Global and Local Device Power Control Logic
- 10 Monitor Timers : Standby/ APMA~D/ Global-Display/ HDD A~B/ SIO & Audio/ GPIO.
- 2 Low Battery timers supported.
- Provides System Activity and Display Activity Monitoring, including
- Video
 - Audio
 - Hard Disk
 - Floppy Disk
 - Serial Ports
 - Parallel Port
 - Keyboard
 - 4 Programmable I/O Groups
 - 2 Programmable Memory Spaces
- Provides Hot Plugging Event Detection
- Docking Insert
- Multiple External Wakeup Events of Standby Mode (G0)
- Power Button
 - Sleep Button
 - Modem Ring
 - RTC Alarm
 - DRQ2
- Resume Events Detected Wake Up from Suspend Mode (G1, G2)
- 9 resume events supported.
 - Power Button
 - Sleep Button
 - RTC Alarm
 - PCI PMEJ Signal
 - Modem Ring
 - USB Events
 - AC' 97
 - Hotkey KBD & MS
 - IRQ1 & 12
- CLKRUN# Function Supported for PCI Mobile Design Guide Ver. 1.1
- Thermal Alarm Supported
- Clock Generator Control Logic Supported

- CPUCLK Stop Control
- PCICLK Stop Control
- L2 Cache Power Down Control Logic Supported
- Up to 25 Run Time Events Supported (included 8 Extended Run Time Events).

Up to 12 General Purpose Input Signals, up to 15 General Purpose Output Signals and up to 30 General Purpose Input/Output Signals

16 Extended General Purpose Input Signals, 16 Extended General Purpose Output Signals, and 8 Extended Run Time Events supported.

All Registers Readable/Restorable for Proper Resume from Suspend State

Hotkey for Power on Button Function through Keyboard or Mouse

Supports Power Loss Recovery

Watch Dog Timer for

-- Setting a Bit in Register

-- Generating an SMIJ/SCI/NMI/INIT

-- Generating System Reset

Built-in PCI IDE Controller

Supports Ultra DMA Mode Transfers up to Mode 5 Timing (100 Mbytes/sec)

Supports PIO Modes up to Mode 4 Timings, and Multiword DMA Mode 0,1,2 with Independent Timing of up to 4 Drives

Integrated 48 x 16-bit Read Ahead & Posted Write Buffers for each channel (Total : 48 DWords)

- Dedicated ATA Interface signals for each channel
 - Supports Tri-state IDE Signals for Swap Bay
- Supports Command Queue IDE enhancement

USB Interface

- Up to six (6) USB ports with two (2) USB host controllers based on the OpenHCI 1.0a Specification
- Supports FS (12Mbits/sec) and LS (1.5Mbits/sec) Serial Transfer
- Supports Legacy Keyboard and Mouse Software with USB-based Keyboard and Mouse

■ SMBus Interface

System Management Bus Interface meets the V1.0 Specification

SMBALERT# Support

Super I/O Interface

Supports Windows Plug-and-Play

Supports 2 Serial/ 1 Parallel/ FDC Functions

Supports 16-bit Address Decoder

- Automatic media sense support
- 2.88 MB (Formatted) Floppy Disk Controller
- Software Compatible with 82077 and Supports 16-byte Data FIFOs
- High Performance Internal Data Separator
- Supports Standard 1 Mbps/ 500 Kbps/ 300 Kbps/ 250 Kbps Data Transfer Rate
- Supports 3 modes of 3.5" FDD (720KB/ 1.2MB/ 1.44MB)
- Swappable Drives A and B
- Programmable 7-bit I/O Base Address
- Various Mode Parallel Port
- Standard Mode
- Programmable 8-bit I/O Base Address
- Multiplexing of FDC Signals through Parallel Port Pins
- 12 IRQ Channel Options
- 4 8-bit DMA Channel Options
- IBM PC/XT, PC/AT and PS/2 Compatible Bi-directional Parallel Port
- Enhanced Mode
- Enhanced Parallel Port (EPP) Compatible
- EPP is compatible with EPP1.9 (IEEE 1284 Compliant), also supports EPP1.7 of Xircom Specification
- High Speed Mode
- Microsoft and Hewlett Packard Extended Capabilities Port (ECP) Compatible
- IEEE 1284 Compatible ECP
- Includes Protection Circuit against damage caused when printer is powered up, or operated at higher voltages
- Serial Ports
- Three High Performance 16450/16550 Compatible UARTs with Send/Receive 16-byte FIFOs
- Programmable Baud Rate Generator
- Wireless Communications
- Dedicated signals and COM Port for Infrared Transmission
- Supports IrDA 1.0 (SIR) and IrDA 1.1 (MIR and FIR)
- Supports Sharp-IR
- MIDI (Musical Instrument Digital Interface) Compatible
- High Performance Power Management for FDC, UART and Parallel Port
- Option between Programmable 7-bit I/O Base Addresses, 12 IRQs, and 4 DMA Channels for each device

Audio System

- Fully Plug-and-Play PCI controller and software
- PCI 2.2 compliant bus master optimized for multiple stream operation.
- On-chip per voice cache to minimize PCI bandwidth use
- Hardware multi-channel digital mixer
- 32 voices polyphony wavetable synthesizer supports all combinations of stereo/mono, 8-/16-bit, and signed/unsigned samples.
- Per channel for wave table synthesis with envelop, pitch shift, tremolo and vibrato
- DLS1-compliant Downloadable Sample support
- DirectMusic with unlimited downloadable samples in system memory
- Legacy game audio with SoundBlaster Pro/16 compatibility
- Legacy game FM and wave table synthesis supported
- MPU-401 compatible MIDI I/O with FIFO
- AC97 2.1 support with full duplex, independent sample rate converter for recording and playback
- High precision internal 26-bit digital mixer with 20-bit digital audio output
- Microsoft WDM streaming architecture compliant and "Re-routable endpoint" support
- 32-voice DirectSound channels
- 16-voice DirectSound3D accelerator with IID, ITD and Doppler effect on 3D positional audio buffer

- DirectSound accelerator with volume, pan and pitch shift control on streaming or static buffers
- DirectInput support with digital enhanced game port enables an analog joystick to emulate digital joystick performance using DirectInput driver. This eliminates up to 12% CPU overhead wasted on joystick polling.
- DirectX timer for video/audio synchronization
- Hardware digital volume control
- Supports Consumer SPDIF Output
- Supports Consumer SPDIF Input

Software Modem Interface

- The M1535+ provides the AC' 97 2.1 compliant digital controller interface for third parties (such as the AMC Codec's vendor) to enable the software modem solution.
- 4 separate telephony bus master channels. One for modem output, one for modem input, one for handset input, and one for handset output.
- AC' 97 2.1 Modem variable sample rate support for "On Demand" sample transport scheme.
- AC' 97 2.1 GPIO signal status and control support.
- Power Management and wake-up event support
- Caller ID string transmission via AC-link support

352-pin (27mmx27mm) BGA Package