

All rights strictly reserved. Reproduction or issue to third parties in any form whatever is not permitted without written authority from the proprietor. Property of Rosenberger Hochfrequenztechnik.

fuer diese technische Unterlage behalten wir uns alle Rechte vor (DIN 34)

AL_GESAMTZ_D00
Reihen: 99-10-26

ISO-Projektion
Methode E

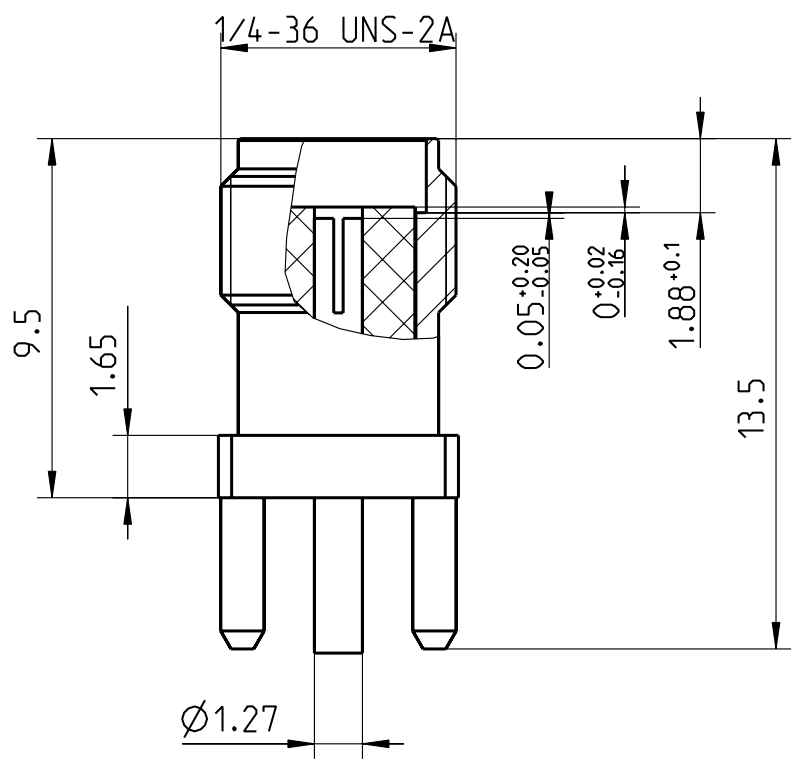
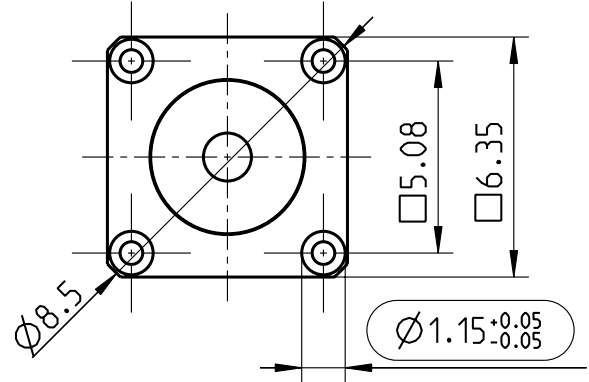

Rosenberger Hochfrequenztechnik 84526 Tittmoning Pro/ENGINEER			<i>assembly instr.:</i> --- <i>panel piercing:</i> B 30		<i>scale:</i> 5:1 (1:1)	<i>crimp insert:</i> --- <i>cable:</i> ---
			<i>date</i> drawn 09.06.99 check.	<i>name</i> F_OELLER	<i>series:</i> SMA MIL-C-39012	
			<i>finish:</i> D3		<i>title:</i> Gehaeusekuppler Bulkhead Jack Loet solder	
b	00-0212	09.05.00	F_OE	<i>part-no.:</i> 32K10E-400		<i>edv-no.:</i> 1320.91200
a	---	09.06.99	F_OE	<i>sheet.</i> 1		<i>of:</i> 1
rev.	<i>change-no</i>	<i>date</i>	<i>name</i>	<i>distrib-</i> FE . AZ QSM RMT . tion to: . . X . .	<i>remarks:</i> x	