



## 3.3V EEPROM PROGRAMMABLE CLOCK GENERATOR

**IDT5V9885  
ADVANCE  
INFORMATION**

### FEATURES:

- Three internal PLLs
- Internal non-volatile EEPROM
- JTAG and FAST mode I<sup>2</sup>C serial interfaces
- Input Frequency Ranges: 1MHz to 400MHz
- Output Frequency Ranges: 4.9kHz to 500MHz
- Reference Crystal Input with programmable oscillator gain and programmable linear load capacitance
  - Crystal Frequency Range: 8MHz to 50MHz
- Each PLL has an 8-bit pre-scaler and a 12-bit feedback-divider
- 10-bit post-divider blocks
- Fractional Dividers
- Two of the PLLs support Spread Spectrum Generation capability
- I/O Standards:
  - Outputs - 3.3V LVTTTL/LVCMOS, LVPECL, and LVDS
  - Inputs - 3.3V LVTTTL/LVCMOS
- Programmable Slew Rate Control
- Programmable Loop Bandwidth Settings
- Programmable output inversion to reduce bimodal jitter
- Redundant clock inputs with glitchless auto and manual switchover options
- JTAG Boundary Scan
- Individual output enable/disable
- Power-down mode
- 3.3V V<sub>DD</sub>
- Available in TQFP and VQFPN packages

### DESCRIPTION:

The IDT5V9885 is a programmable clock generator intended for high performance data-communications, telecommunications, consumer, and networking applications. There are three internal PLLs, each individually programmable, allowing for three unique non-integer-related frequencies. The frequencies are generated from a single reference clock. The reference clock can come from one of the two redundant clock inputs. A glitchless automatic or manual switchover function allows any one of the redundant clocks to be selected during normal operation.

The IDT5V9885 can be programmed through the use of the I<sup>2</sup>C or JTAG interfaces. The programming interface enables the device to be programmed when it is in normal operation or what is commonly known as in-system programmable. An internal EEPROM allows the user to save and restore the configuration of the device without having to reprogram it on power-up. JTAG boundary scan is also implemented.

Each of the three PLLs has an 8-bit pre-scaler and a 12-bit feedback divider. This allows the user to generate three unique non-integer-related frequencies. The PLL loop bandwidth is programmable to allow the user to tailor the PLL response to the application. For instance, the user can tune the PLL parameters to minimize jitter generation or to maximize jitter attenuation. Spread spectrum generation and fractional divides are allowed on two of the PLLs.

There are 10-bit post dividers on five of the six output banks. Two of the six output banks are configurable to be LVTTTL, LVPECL, or LVDS. The other four output banks are LVTTTL. The outputs are connected to the PLLs via the switch matrix. The switch matrix allows the user to route the PLL outputs to any output bank. This feature can be used to simplify and optimize the board layout. In addition, each output's slew rate and enable/disable function can be programmed.

## FUNCTIONAL BLOCK DIAGRAM

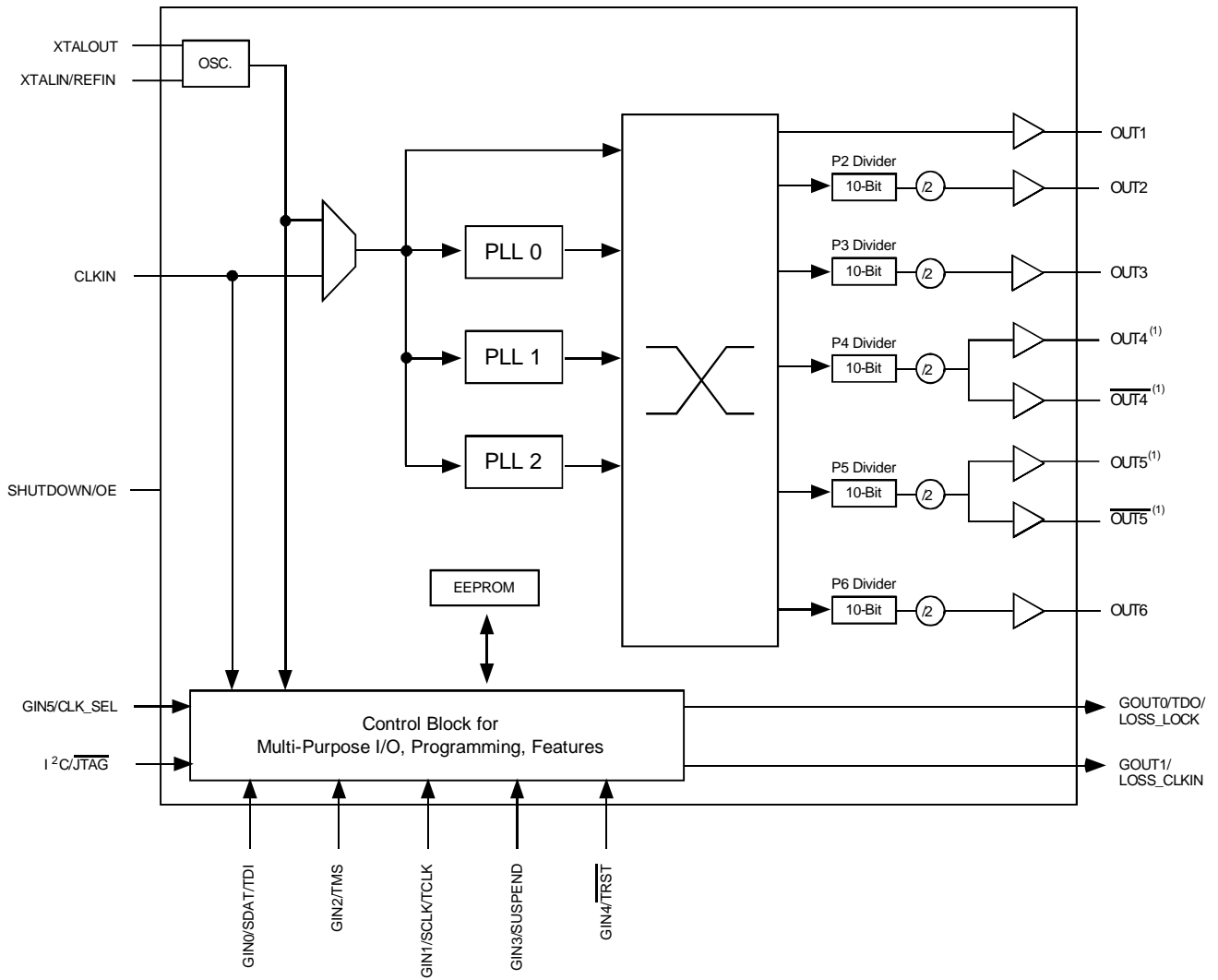

**NOTE:**  
1. OUT4 and OUT5 pairs can be configured to be LVDS, LVPECL, or two single-ended LVTTTL outputs. As LVTTTL,  $\overline{\text{OUT4}}$  and  $\overline{\text{OUT5}}$  can be configured to be non-inverting.

## PIN CONFIGURATION

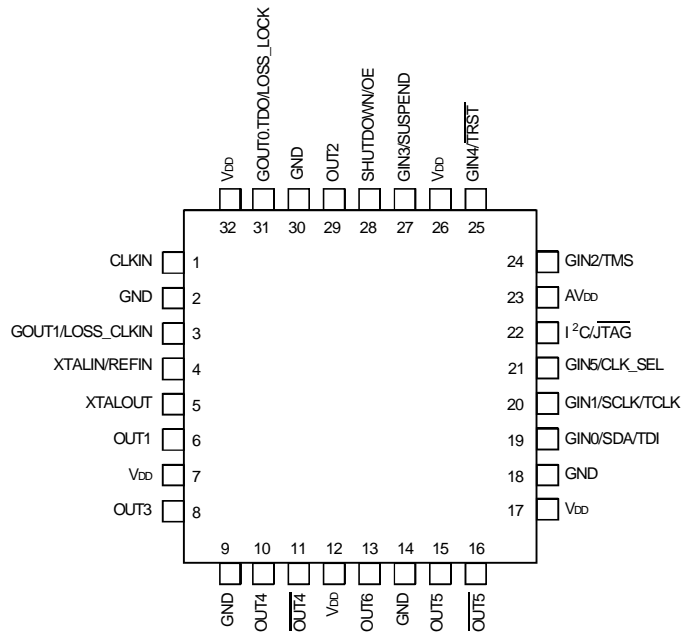

TQFP  
TOP VIEW

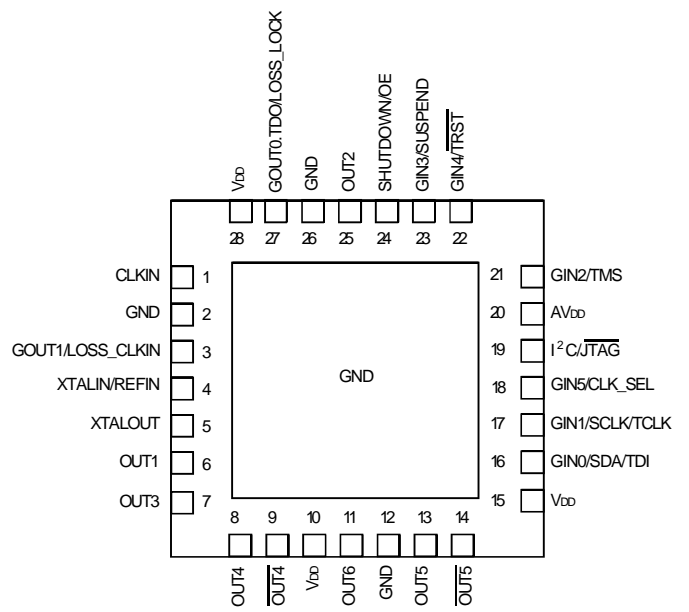

VFQFPN  
TOP VIEW

## PIN DESCRIPTION

Pin Name	PF32 Pin#	NL28 Pin#	I/O	Type	Description
CLKIN	1	1	I	LVTTTL	Input Clock
XTALIN/REFIN	4	4	I	LVTTTL	CRYSTAL_IN - Reference crystal input or external reference clock input
XTALOUT	5	5	O	LVTTTL	CRYSTAL_OUT - Reference crystal feedback
GIN0/SDAT/TDI	19	16	I	LVTTTL <sup>(3)</sup>	Multi-purpose inputs. Can be used for Frequency Control, SDAT(I <sup>2</sup> C), or TDI(JTAG).
GIN1/SCLK/TCK	20	17	I	LVTTTL <sup>(3)</sup>	Multi-Purpose inputs. Can be used for Frequency Control, SCLK(I <sup>2</sup> C), or TCK(JTAG).
GIN2/TMS	24	21	I	LVTTTL <sup>(3)</sup>	Multi-Purpose inputs. Can be used for Frequency Control or TMS (JTAG)
GIN3/SUSPEND	27	23	I	LVTTTL <sup>(3)</sup>	Multi-Purpose inputs. Can be used for Frequency Control or as a suspend mode control input (active HIGH).
GIN4/ $\overline{\text{TRST}}$	25	22	I	LVTTTL <sup>(3)</sup>	Multi-Purpose inputs. Can be used for Frequency Control or $\overline{\text{TRST}}$ (JTAG)
GIN5/CLK_SEL	21	18	I	LVTTTL <sup>(3)</sup>	Multi-Purpose inputs. Can be used for Frequency Control or input clock selector.
SHUTDOWN/OE	28	24	I	LVTTTL <sup>(3)</sup>	Enables/disables the outputs or powers down the chip. The SP bit (0x1C) controls the polarity of the signal to be either active HIGH or LOW. (Default is active HIGH.)
I <sup>2</sup> C/JTAG	22	19	I	3-level <sup>(2)</sup>	I <sup>2</sup> C (HIGH) or MFC Mode (MID) or JTAG Programming (LOW)
OUT1	6	6	O	LVTTTL	Configurable clock output 1. Can also be used to buffer the reference clock.
OUT2	29	25	O	LVTTTL	Configurable clock output 2
OUT3	8	7	O	LVTTTL	Configurable clock output 3
OUT4	10	8	O	Adjustable <sup>(1)</sup>	Configurable clock output 4, Single-Ended or Differential when combined with $\overline{\text{OUT4}}$
$\overline{\text{OUT4}}$	11	9	O	Adjustable <sup>(1)</sup>	Configurable complementary clock output 4, Single-Ended or Differential when combined with OUT4
OUT5	15	13	O	Adjustable <sup>(1)</sup>	Configurable clock output 5, Single-Ended or Differential when combined with $\overline{\text{OUT5}}$
$\overline{\text{OUT5}}$	16	14	O	Adjustable <sup>(1)</sup>	Configurable complementary clock output 5, Single-Ended or Differential when combined with OUT5
OUT6	13	11	O	LVTTTL	Configurable clock output 6
GOUT0/TDO/LOSS_LOCK	31	27	O	LVTTTL <sup>(3)</sup>	Multi-Purpose Output. Can be programmed to use as PLL LOCK signal, LOSS_LOCK or TDO in JTAG mode
GOUT1/LOSS_CLKIN	3	3	O	LVTTTL	Multi-Purpose Output. Can be programmed to use as LOSS_CLKIN
V <sub>DD</sub>	7,12,17,26,32	10,15,28			Power Supply for the output buffers
A <sub>V</sub> DD	23	20			Analog power supply
GND	2,9,14,18,30	2,12,26			Ground

### NOTES:

- Outputs are user programmable to drive single-ended 3.3V LVTTTL, differential LVDS, or differential LVPECL interface levels.
- 3-level inputs are static inputs and must be tied to V<sub>DD</sub> or GND or left floating. These inputs are internally biased to V<sub>DD</sub>/2. They are not hot-insertable or over voltage tolerant.
- The JTAG (TDO, TMS, TCLK,  $\overline{\text{TRST}}$ , and TDI) and I<sup>2</sup>C (SCLK and SDAT) signals share the same pins with GIN signals.

## PLL FEATURES AND DESCRIPTIONS

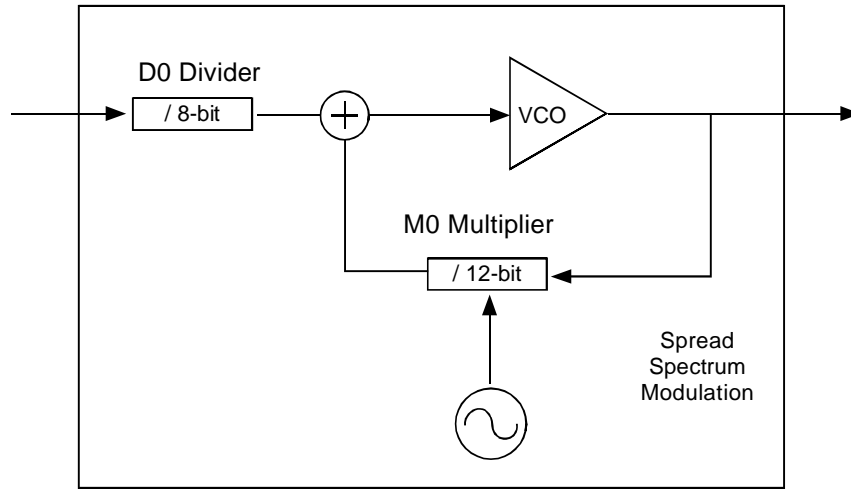

*PLL0 Block Diagram*

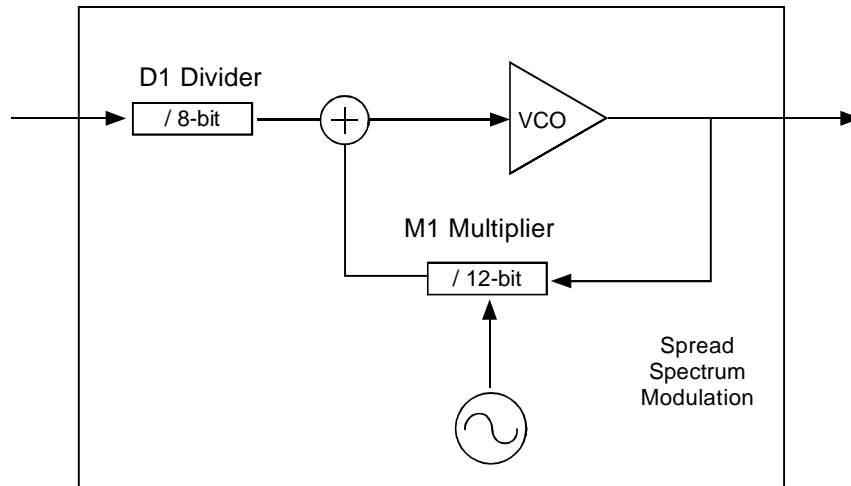

*PLL1 Block Diagram*

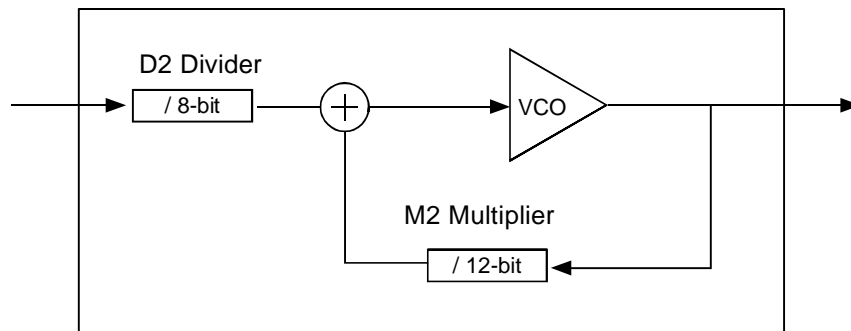

*PLL2 Block Diagram*

	Pre-Divider (D) Values	Multiplier (M) Values	Programmable Loop Bandwidth	Spread Spectrum Generation Capability
PLL0	1 - 255	2 - 8190	yes	yes
PLL1	1 - 255	2 - 8190	yes	yes
PLL2	1 - 255	1 - 4095	yes	no

## REFERENCE CLOCK INPUT PINS AND SELECTION

The 5V9885 supports up to two clock inputs. One of the clock inputs (XTALIN/REFIN) can be driven by either an external crystal or a reference clock. The second clock input (CLKIN) can only be driven from an external reference clock. Either clock input can be set as the primary clock. The primary clock designation is to establish which is the main reference clock to the PLLs. The non-primary clock is designated as the secondary clock in case the primary clock goes absent and a backup is needed. The PRIMCLK bit (0x34) determines which clock input will be the primary clock. When PRIMCLK bit is "0", it will select XTALIN/REFIN as the primary, and when "1", it will select CLKIN as the primary. The two external reference clocks can be manually selected using the GIN5/CLK\_SEL pin, except in Manual Frequency Control (MFC) mode 2, or via programming by hard wiring the CLK\_SEL pin and toggling the PRIMCLK bit. For more details on the MFC modes, refer to the CONFIGURING MULTI-PURPOSE I/Os section. When CLK\_SEL is LOW, the primary clock is selected and when HIGH, the secondary clock is selected. The SM bits (0x34) must be set to "0x" for manual switchover which is detailed in SWITCHOVER MODES section.

GIN5/CLK_SEL	Selected Clock Input
L	Primary
H	Secondary

### Crystal Input (XTALIN/REFIN)

The crystal oscillators should be fundamental mode quartz crystals: overtone crystals are not suitable. Crystal frequency should be specified for parallel resonance with 50Ω maximum equivalent series resonance.

When the XTALIN/REFIN pin is driven by a crystal, it is important to set the internal oscillator inverter drive strength and internal tuning/load capacitor values correctly to achieve the best clock performance. These values are programmable through either I<sup>2</sup>C or JTAG interface to allow for maximum compatibility with crystals from various manufacturers, processes, performances, and qualities. The internal load capacitors are true parallel-plate capacitors for ultra-linear performance. Parallel-plate capacitors were chosen to reduce the frequency shift that occurs when non-linear load capacitance interacts with load, bias, supply, and temperature changes. External non-linear crystal load capacitors should not be used for applications that are sensitive to absolute frequency requirements. The value of the internal load capacitors are determined by XTALCAP[7:0] bits, (0x07). The load capacitance can be set with a resolution of 0.125 pF for a total crystal load range of 3.5pF to 35.4pF. Check with the vendor's crystal load capacitance specification for the exact setting to tune the internal load capacitor. The following equation governs how the total internal load capacitance is set.

$$XTAL \text{ load cap} = 3.5\text{pF} + XTALCAP[7:0] * 0.125\text{pF} \quad (\text{Eq. 1})$$

Parameter	Bits	Step	Min	Max	Units
XTALCAP	8	0.125	0	32	pF

When using an external reference clock instead of a crystal on the XTAL/REFIN pin, the input load capacitors may be completely bypassed. This allows for the input frequency to be up to 200MHz. When using an external reference clock, the XTALOUT pin must be left floating, XTALCAP must be programmed to the default value of "0", and crystal drive strength bit, XDRV (0x06), must be set to the default value of "11".

### CLKIN Pin

CLKIN pin is a regular clock input pin, and can be driven up to 400MHz.

## PRE-SCALER, FEEDBACK-DIVIDER, AND POST-DIVIDER

Each PLL incorporates an 8-bit pre-scaler and a 12-bit feedback divider which allows the user to generate three unique non-integer-related frequencies. For output banks OUT2-OUT6, each bank has a 10-bit post-divider. The following equation governs how the frequency on output banks OUT2-6 is calculated.

$$F_{OUT} = \frac{F_{IN} * \left(\frac{M}{D}\right)}{P * 2} \quad (\text{Eq. 2})$$

Where F<sub>IN</sub> is the reference frequency, M is the total feedback-divider value, D is the pre-scaler value, P is the total post-divider value, and F<sub>OUT</sub> is the resulting output bank frequency. The value 2 in the denominator is due to the divide-by-2 on each of the output banks OUT2-6. Note that OUT1 does not have any type of post-divider. Also, programming any of the dividers may cause glitches on the outputs.

### Pre-Scaler

D[7:0] are the bits used to program the pre-scaler for each PLL, D0 for PLL0, D1 for PLL1, and D2 for PLL2. The pre-scalers divide down the reference clock with integer values ranging from 1 to 255. To maintain low jitter, the divided down clock must be higher than 400KHz; it is best to use the smallest D divider value possible. If D is set to '0x00', then this will power down the PLL and all the outputs associated with that PLL.

### Feedback-Divider

N[11:0] and A[3:0] are the bits used to program the feedback-divider for PLL0 (N0 and A0) and PLL1 (N1 and A1). If spread spectrum generation is enabled for either PLL0 or PLL1, then the SS\_OFFSET[5:0] bits (0x61, 0x69) would be factored into the overall feedback divider value. See the SPREAD SPECTRUM GENERATION section for more details on how to configure PLL0 and PLL1 when spread spectrum is enabled. The two PLLs can also be configured for fractional divide ratios. See FRACTIONAL DIVIDER for more details. For PLL2, only the N[11:0] bits (N2) are used to program its feedback divider and there is no spread spectrum generation and fractional divides capability. The 12-bit feedback-divider integer values range from 1 to 4095.

The following equations govern how the feedback divider value is set. Note that the equations are different for PLL0/PLL1 and PLL2

#### PLL0 and PLL1:

$$M = 2 * N[11:0] + A[3:0] + 1 + SS\_OFFSET[5:0] * 1/64 \quad (\text{Eq. 3})$$

$$M = 2 * N[11:0] + A[3:0] + 1 \quad (\text{spread spectrum disabled}) \quad (\text{Eq. 4})$$

- A[3:0] = 0000 = -1
- = 0001 = 1
- = 0010 = 2
- = 0011 = 3
- .
- .
- .
- = 1111 = 15

Note: A[3:0] < (N[11:0] - 1), must be met when using A.

#### PLL2:

$$M = N[11:0] \quad (\text{Eq. 5})$$

The user can achieve an even or odd integer divide ratio for both PLL0 and PLL1 by setting the A[3:0] bits accordingly and disabling the spread spectrum. A fractional divide can also be set for PLL0 and PLL1 by using the A[3:0] bits in conjunction with the SS\_OFFSET[5:0] bits, which is detailed in the FRACTIONAL DIVIDER section. Note that the VCO has a frequency range of 10MHz to 1100MHz. To maintain low jitter, it is best to maximize the VCO frequency. For example, if the reference clock is 100MHz and a 200MHz clock is required, to achieve the best jitter performance, multiply the 100MHz by 11 to get the VCO running at the highest possible frequency of 1100MHz and then divide it down to get 200MHz. Or if the reference clock is 25MHz and 20MHz is the required clock, multiply the 25MHz by 40 to get the VCO running at 1000MHz and then divide it down to get 20MHz. If N is set to '0x00', the VCO will slew to the minimum frequency.

### Post-Divider

Q[9:0] are the bits used to program the 10-bit post-dividers on output banks OUT2-6. OUT1 bank does not have a 10-bit post-divider or any other post-divide along its path. The 10-bit post-dividers will divide down the output banks' frequency with integer values ranging from 1 to 1023.

There is the option to choose between disabling the post-divider, utilizing a div/1, a div/2, or the 10-bit post-divider by using the PM[1:0] bits. Each bank, except for OUT1, has a set of PM bits. When disabling the post-divider, no clock will appear at the outputs, but will remain powered on. The values are listed in the table below.

PM[1:0]	P Post-Divider
00	disabled
01	div/1
10	div/2
11	Q[9:0] + 2 (Eq. 6)

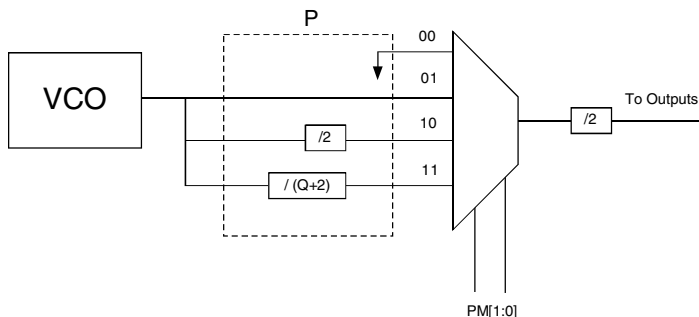

Post-Divider Diagram

Note that the actual 10-bit post-divider value has a 2 added to the integer value Q and the outputs are routed through another div/2 block. The post-divider should never be disabled unless the output bank will never be used during normal operation. The output frequency range for LVTTTL outputs are from 4.9KHz to 200MHz. The output frequency range for LVPECL/LVDS outputs are from 4.9KHz to 500MHz.

## SPREAD SPECTRUM GENERATION

PLL0 and PLL1 support spread spectrum generation capability, which users have the option of turning on and off. Spread spectrum profile, frequency, and spread are fully programmable (within limits). The programmable spread spectrum generation parameters are TSSC[3:0], NSSC[3:0], SS\_OFFSET[5:0], SD[3:0], DITH, and X2 bits. These bits are in the memory address range of 0x60 to 0x67 for PLL0 and 0x68 to 0x6F for PLL1. The spread spectrum generation on PLL0 & PLL1 can be enabled/disabled using the TSSC[3:0] bits. To enable spread spectrum, set TSSC > '0' and set NSSC, SD[3:0], SD[5:0], and the A[3:0] in the total M value accordingly. And to disable, set TSSC = '0'.

### TSSC[3:0]

These bits are used to determine the number of phase/frequency detector cycles per spread spectrum cycle (ssc) steps. The modulation frequency can be calculated with the TSSC bits in conjunction with the NSSC bits. Valid TSSC integer values for the modulation frequency range from 5 to 14.

### NSSC[3:0]

These bits are used to determine the number of delta-encoded samples used for a single quadrant of the spread spectrum waveform. All four quadrants of the spread spectrum waveform are mirror images of each other. The modulation frequency is also calculated based off the NSSC bits in conjunction with the TSSC bits. Valid NSSC integer values range from 1 to 6.

### SS\_OFFSET[5:0]

These bits are used to program the fractional offset with respect to the nominal M integer value. For center spread, the SS\_OFFSET should be set to '0' so the spread spectrum waveform is about the nominal M (Mnom) value. For down spread, the SS\_OFFSET > '0' so the spread spectrum waveform is about the (Mideal - 1 = Mnom) value. The downspread percentage can be thought of in terms of center spread. For example, a downspread of -1% can also be considered as a center spread of ±0.5% but with Mnom shifted down by one and offset. The SS\_OFFSET has integer values ranging from 0 to 63.

### SD[3:0]

These bits are used to shape the profile of the spread spectrum waveform. These are delta-encoded samples of the waveform. There are twelve sets of SD samples for each PLL. The NSSC bits determine how many of these samples are used for the waveform. The sum of these delta-encoded samples (sigma-delta-encoded samples) determine the amount of spread and should not exceed (63 - SS\_OFFSET). The maximum spread is inversely proportional to the nominal M integer value.

### DITH

This bit is for dithering the sigma-delta-encoded samples. This will randomize the least-significant bit of the input to the spread spectrum modulator. Set the bit to '1' to enable dithering.

### X2

This bit will double the total value of the sigma-delta-encoded-samples which will increase the amplitude of the spread spectrum waveform by a factor of two. When X2 is '0', the amplitude remains nominal but if set to '1', the amplitude is increased by x2.

The following equations govern how the spread spectrum is set:

$$T_{ssc} = TSSC[3:0] + 2 \quad (\text{Eq. 7})$$

$$N_{ssc} = NSSC[3:0] * 2 \quad (\text{Eq. 8})$$

$$SD[3:0]_k = S_{j+1}(\text{unencoded}) - S_j(\text{unencoded}) \quad (\text{Eq. 9})$$

where  $S_j$  is the unencoded sample out of a possible 12 and  $SD_k$  is the delta-encoded sample out of a possible 12.

$$\text{Amplitude} = \frac{(2 * N[11:0] + A[3:0] + 1) * \text{Spread\%} / 100}{2} \quad (\text{Eq. 10})$$

if  $1 < \text{Amp} < 2$ , then set X2 bit to '1'.

**Modulation frequency:**

$$F_{\text{PFD}} = F_{\text{IN}} / D \quad (\text{Eq. 11})$$

$$F_{\text{VCO}} = F_{\text{PFD}} * M_{\text{NOM}} \quad (\text{Eq. 12})$$

$$F_{\text{SSC}} = F_{\text{PFD}} / (4 * N_{\text{SSC}} * T_{\text{SSC}}) \quad (\text{Eq. 13})$$

**Spread:**

$$\Sigma\Delta = SD_0 + SD_1 + SD_2 + \dots + SD_{11}$$

the number of samples used depends on the N<sub>SSC</sub> value

$$\Sigma\Delta \leq 63 - \text{SS\_OFFSET}$$

$$\pm\text{Spread\%} = \frac{\Sigma\Delta * 100}{64 * (2 * N[11:0] + A[3:0] + 1)} \quad (\text{Eq. 14})$$

$$\pm\text{Max Spread\%} / 100 = 1 / M_{\text{NOM}} \text{ or } 2 / M_{\text{NOM}} (X2=1)$$

**Profile:**

Waveform starts with SS\_OFFSET, SS\_OFFSET + SD<sub>J</sub>, SS\_OFFSET + SD<sub>J+1</sub>, etc.

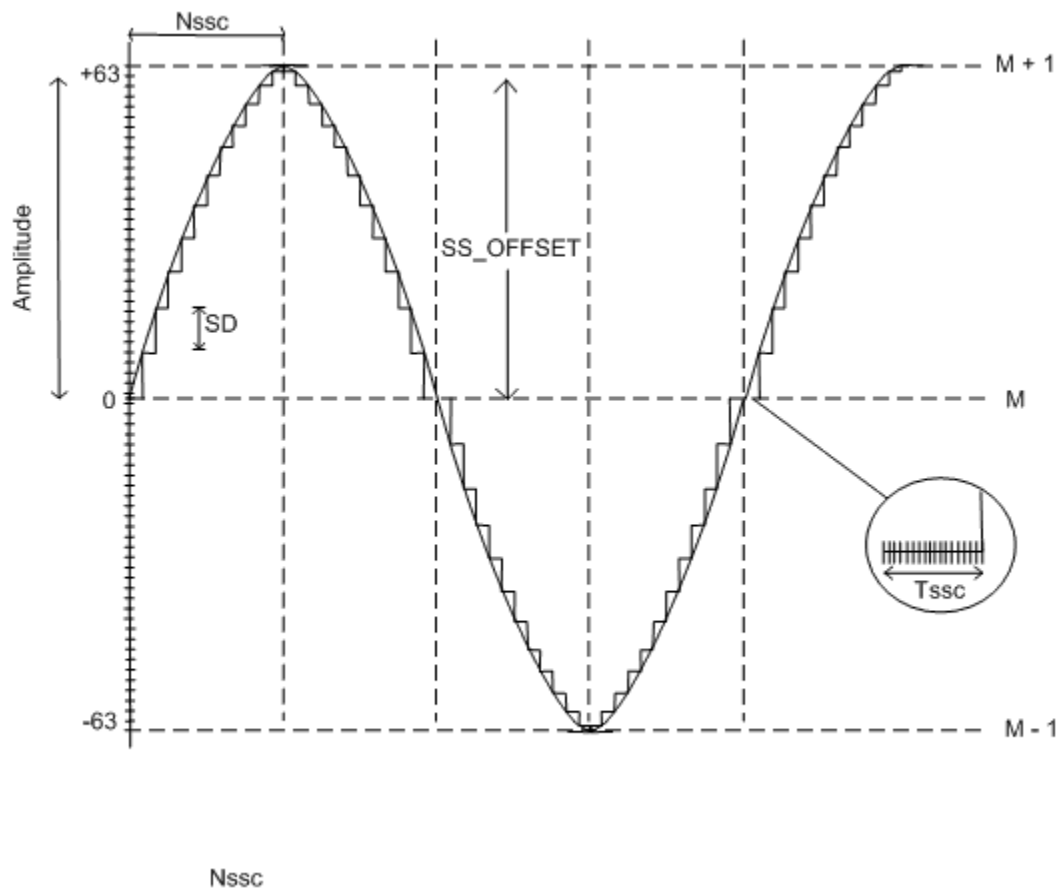

*Spread Spectrum Using Sinusoidal Profile*

### Example

$F_{IN} = 25\text{MHz}$ ,  $F_{OUT} = 100\text{MHz}$ ,  $F_{SSC} = 33\text{KHz}$  with center spread of  $\pm 2\%$ . Find the necessary spread spectrum register settings.

Since the spread is center, the SS\_OFFSET can be set to '0'. Solve for the nominal M value; keep in mind that the nominal M should be chosen to maximize the VCO. Start with  $D = 1$ , using Eq.10 and Eq.11.

$$M_{NOM} = 1100\text{MHz} / 25\text{MHz} = 44$$

Using Eq.4, we arbitrarily choose  $N = 20$ ,  $A = 3$ . Now that we have the nominal M value, we can determine TSSC and NSSC by using Eq.12.

$$N_{SSC} * T_{SSC} = 25\text{MHz} / (33\text{KHz} * 4) = 190$$

However, using Eq. 7 and Eq.8, we find that the closest value is when  $TSSC = 14$  and  $NSSC = 6$ . Keep in mind to maximize the number of samples used to enhance the profile of the spread spectrum waveform.

$$T_{SSC} = 14 + 2 = 16$$

$$N_{SSC} = 6 * 2 = 12$$

$$N_{SSC} * T_{SSC} = 192$$

Use Eq.14 to determine the value of the sigma-delta-encoded samples.

$$\pm 2\% = \frac{\Sigma\Delta * 100}{64 * 44}$$

$$\Sigma\Delta = 56.32$$

Either round up or down to the nearest integer value. Therefore, we end up with 56 or 57 for sigma-delta-encoded samples. Since the sigma-delta-encoded samples must not exceed 63 with SS\_OFFSET set to '0', 56 or 57 is well within the limits. It is the discretion of the user to define the shape of the profile that is better suited for the intended application.

Using Eq.14 again, the actual spread for the sigma-delta-encoded samples of 56 and 57 are  $\pm 1.99\%$  and  $\pm 2.02\%$ , respectively.

Use Eq.10 to determine if the X2 bit needs to be set;

$$\text{Amplitude} = \frac{44 * (1.99 \text{ or } 2.02) / 100}{2} = 0.44 < 1$$

Therefore, the X2 = '0'. The dither bit is left to the discretion of the user.

The example above was of a center spread using spread spectrum. For down spread, the nominal M value can be set one integer value lower to 43.

Note that the 5v9885 should not be programmed with  $TSSC > '0'$ ,  $SS\_OFFSET = '0'$ , and  $SD = '0'$  in order to prevent an unstable state in the modulator. The PLL loop bandwidth must be at least 10x the modulation frequency along with higher damping (larger  $\omega_{uz}$ ) to prevent the spread spectrum from being filtered and reduce extraneous noise. Refer to the LOOP FILTER section for more detail on  $\omega_{uz}$ . The A[3:0] must be used for spread spectrum, even if the total multiplier value is an even integer.

## FRACTIONAL DIVIDER

There is the option for the feedback-divider to be programmed as a fractional divider for only PLL0 and PLL. By setting  $TSSC > '0'$  and SD bits to '0', the SS\_OFFSET bits would determine the fractional divide value. See the SPREAD SPECTRUM GENERATION section for more details on the TSSC, SD, and SS\_OFFSET bits. The following equation governs how the fractional divide value is set.

$$M = 2 * N[11:0] + A[3:0] + 1 + SS\_OFFSET[5:0] * 1/64$$

The spread spectrum parameters such as the modulation frequency and profile will not be enabled nor will it have any impact on the PLL output when the PLL is programmed for fractional divide.

The following is an example of how to set the fractional divider.

#### Example

$$F_{IN} = 20\text{MHz}, F_{OUT1} = 168.75\text{MHz}, F_{OUT2} = 350\text{MHz}$$

Solving for 350MHz using Eq.2 and Eq.3 with PLL0 and spread spectrum off,

$$350\text{MHz} = \frac{20\text{MHz} * (M / D)}{P * 2}$$

For better jitter performance, keep D as small as possible

$$\frac{350\text{MHz} * 2}{20\text{MHz}} = \frac{M}{P} = \frac{35}{1}$$

Therefore, we have D = 1, M = 35 (N = 16, A = 2) for PLL0 with P = 1 on output bank4 resulting in 350MHz.

Solving for 168.75MHz with PLL1 and fractional divide enabled:

$$168.75\text{MHz} = \frac{20\text{MHz} * (M / D)}{P * 2}$$

$$\frac{168.75\text{MHz} * 2}{20\text{MHz}} = \frac{M}{P} = \frac{16.875}{1} \text{ or } \frac{33.75}{2}$$

The 33.75 value is chosen to achieve the highest VCO frequency possible. Next step is to figure out the setting for the fractional divide using Eq.3.

$$33.75 = 2 * N + A + 1 + \text{SS\_OFFSET} * 1/64$$

Integer value 33 can be determined by N and A, thus leaving 0.75 left to be solved.

$$2 * N + A + 1 = 33$$

$$\text{SS\_OFFSET} = 64 * 0.75 = 48$$

Therefore, we have D=1, M=33.75 (N=15, A=2, SS\_OFFSET=48) for PLL1 with P=2 on an output bank resulting in 168.75MHz.

The fractional divider can be determined if it is needed by following the steps in the previous example. Note that the 5v9885 should not be programmed with TSSC > '0', SS\_OFFSET = '0', and SD = '0' in order to prevent an unstable state in the modulator. The A[3:0] must be used and set to be greater than '2' for a more accurate fractional divide.

## LOOP FILTER

The loop filter for each PLL can be programmed to optimize the jitter performance. The low-pass frequency response of the PLL is the mechanism that dictates the jitter transfer characteristics. The loop bandwidth can be extracted from the jitter transfer. A narrow loop bandwidth is good for jitter attenuation while a wide loop bandwidth is best for low jitter generation. The specific loop filter components that can be programmed are the resistor via the RZ[3:0] bits, pole capacitor via the CZ[3:0] bits, zero capacitor via the CP[3:0] bits, and the charge pump current via the IP[2:0] bits.

The following equations govern how the loop filter is set.

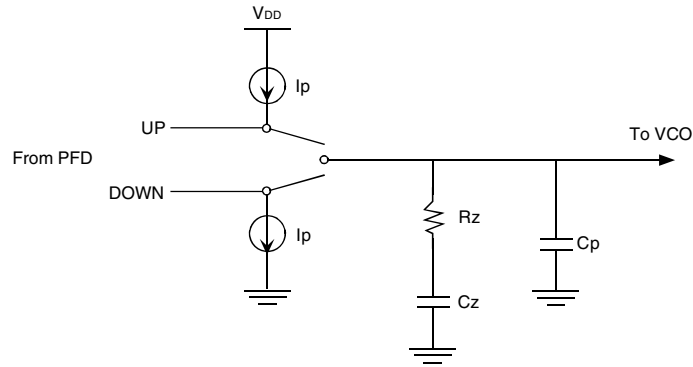

*Charge Pump and Loop Filter Configuration*

$$\text{Resistor (Rz)} = 0.3\text{K}\Omega + \text{RZ}[3:0] * 1\text{K}\Omega \quad (\text{Eq. 15})$$

$$\text{Zero capacitor (Cz)} = 6\text{pF} + \text{CZ}[3:0] * 27.2\text{pF} \quad (\text{Eq. 16})$$

$$\text{Pole capacitor (Cp)} = 1.3\text{pF} + \text{CP}[3:0] * 0.75\text{pF} \quad (\text{Eq. 17})$$

$$\text{Charge pump current (Ip)} = 5 * 2^{\text{IP}[2:0]} \mu\text{A} \quad (\text{Eq. 18})$$

Parameter	Bits	Step	Min	Max	Units
RZ	4	1	0.3	15.3	KΩ
CZ	4	27.2	6	414	pF
CP	4	0.75	1.3	12.55	pF
IP	3	2 <sup>n</sup>	5	640	μA

PLL loop filter design is beyond the scope of this datasheet. Refer to design procedures for 3-order charge-pump based PLLs. For the sake of simplicity, the fastest and easiest way to calculate the PLL loop bandwidth (Fc) given the programmable loop filter parameters is as follows.

### PLL Loop Bandwidth:

$$\text{Charge pump gain (K}\phi\text{)} = \text{Ip} / 2\pi \quad (\text{Eq. 19})$$

$$\text{VCO gain (Kvco)} = 950\text{MHz/V} * 2\pi \quad (\text{Eq. 20})$$

M = Total multiplier value (See the PRE-SCALERS, FEEDBACK-DIVIDERS, POST-DIVIDERS section for more detail)

$$\omega_c = \frac{\text{Rz} * \text{K}\phi * \text{Kvco} * \text{Cz}}{\text{M} * (\text{Cz} + \text{Cp})} \quad (\text{Eq. 21})$$

$$\text{Fc} = \omega_c / 2\pi \quad (\text{Eq. 22})$$

Note, the phase/frequency detector frequency (F<sub>PFD</sub>) is typically seven times the PLL closed-loop bandwidth (Fc) but too high of a ratio will reduce your phase margin thus compromising loop stability.

To determine if the loop is stable, the phase margin ( $\phi_m$ ) would need to be calculated as follows.

**Phase Margin:**

$$\omega_z = 1 / (R_z * C_z) \quad (\text{Eq. 23})$$

$$\omega_p = \frac{C_z + C_p}{R_z * C_z * C_p} \quad (\text{Eq. 24})$$

$$\phi_m = (360 / 2\pi) * [\tan^{-1}(\omega_c / \omega_z) - \tan^{-1}(\omega_c / \omega_p)] \quad (\text{Eq. 25})$$

To ensure stability in the loop, the phase margin is recommended to be  $> 60^\circ$  but too high will result in the lock time being excessively long. Certain loop filter parameters would need to be compromised to not only meet a required loop bandwidth but to also maintain loop stability.

Example

$F_c = 150\text{KHz}$  is the desired loop bandwidth. The total M value is 850. The ratio of  $\omega_p / \omega_c$  should be at least 4. A rule of thumb that will help to aid the way, the  $\omega_p / \omega_c$  ratio should be at least 4. Given  $F_c$  and M, an optimal loop filter setting needs to be solved for that will meet both the PLL loop bandwidth and maintain loop stability.

The charge pump gain should be relatively small as possible to achieve a low loop bandwidth.

$$I_p = 40\mu\text{A}$$

$$K\phi * K_{VCO} = 950\text{MHz/V} * 40\mu\text{A} = 38000\text{A/Vs}$$

Loop Bandwidths

$$\omega_c = 2\pi * F_c = 9.42 \times 10^5 \text{ s}^{-1}$$

$$\omega_z = \omega_p / \omega_c = 4 \quad (\text{Eq. 26})$$

$$\omega_c^2 = \omega_p * \omega_z \quad (\text{Eq. 27})$$

$$\omega_p = \frac{C_z + C_p}{R_z * C_z * C_p} = \omega_z (1 + C_z / C_p)$$

Solving for  $C_z$ ,  $C_p$ , and  $R_z$

Knowing  $\omega_c = \frac{R_z * K\phi * K_{VCO} * C_z}{M * (C_z + C_p)}$  and substituting in the equations from above,

$C_z \gg C_p$ , therefore, we can easily derive  $C_p$  to be

$$C_p = \frac{K\phi * K_{VCO}}{M * \omega_c^2 * \omega_z} = 12.60\text{pF}$$

Similarly for  $C_z$  and  $R_z$

$$C_z = \frac{K\phi * K_{VCO} * (\omega_z^2 - 1)}{M * \omega_c^2 * \omega_z} = 189\text{pF}$$

$$R_z = \frac{M * \omega_c * \omega_z^2}{K\phi * K_{VCO} * (\omega_z^2 - 1)} = 22.48\text{K}\Omega$$

Based on the loop filter parameter equations from above, since there are no possible values of 12.60pF for  $C_p$ , 189pF for  $C_z$ , and 22.48K $\Omega$  for  $R_z$ , the next possible values within the loop filter settings are 12.55pF ( $CP[3:0]=1111$ ), 196.4pF ( $CZ[3:0]=0111$ ), and 15.3K $\Omega$  ( $RZ[3:0]=1111$ ), respectively. This loop filter setting will yield a loop bandwidth of about 102KHz. The phase margin must be checked for loop stability.

$$\phi_m = (360 / 2\pi) * [\tan^{-1}(6.41 \times 10^5 \text{ s}^{-1} / 3.33 \times 10^5 \text{ s}^{-1}) - \tan^{-1}(6.41 \times 10^5 \text{ s}^{-1} / 5.54 \times 10^6 \text{ s}^{-1})] = 56^\circ$$

Although slightly below  $60^\circ$ , the phase margin would be acceptable with a fairly stable loop.

## CONFIGURING THE MULTI-PURPOSE I/Os

The 5V9885 can operate in four distinct modes. These modes are controlled by the MFC bit (0x04) and the I<sup>2</sup>C/JTAG pin. The general purpose I/O pins (GIN0, GIN1, GIN2, GIN3, GIN4, GIN5) have different uses depending on the mode of operation. The four available modes of operation are:

- 1) Manual Frequency Control (MFC) Mode for PLL0 Only
- 2) Manual Frequency Control (MFC) Mode for all three PLLs
- 3) I<sup>2</sup>C Programming Mode
- 4) JTAG Programming Mode

Along with the GINx pins are also GOUTx output pins that can take up a different function depending on the mode of operation. See table below for description.

Multi-Purpose Pins	Other Signal Functions	Signal Description
GIN0	SDAT / TDI	I <sup>2</sup> C serial data input / JTAG serial data input
GIN1	SCLK / TCK	I <sup>2</sup> C clock input / JTAG clock input
GIN2	TMS	JTAG control signal to the TAP controller state machine
GIN3	PLL_SUSPEND	Suspends all outputs of a PLL (Active HIGH)
GIN4	TRST	JTAG active LOW input to asynchronously reset the BST
GIN5	CLK_SEL	Reference clock select between XTALIN/REFIN and CLKIN
GOUT0	TDO / LOSS_LOCK	JTAG serial data output / Detects loss of PLL lock
GOUT1	LOSS_CLKIN	Detects loss of the selected clock source

Each PLL's programming registers can store up to four different Dx and Mx configurations in combination with two different P configurations in MFC modes. The post-divider should never be disabled in any of the two P configurations unless the output bank will never be used during normal operation. The PLL's loop filter settings also has four different configurations to store and select from. This will be explained in the MODE1 and MODE2 sections. The use of the GINx pins in MFC mode control the selection of these configurations.

### MODE1 - Manual Frequency Control (MFC) Mode for PLL0 Only

In this mode, only the configuration of PLL0 can be changed during operation. PLL1 and PLL2 have only one fixed configuration in this mode. The GIN0, GIN1 and GIN2 pins control the selection of up to eight different D0, M0, P, RZ0, CZ0, PZ0, and IP0 stored configurations. GIN3 becomes PLL SUSPEND pin, GIN4 is not available to users, and GIN5 becomes CLK\_SEL pin. The output GOUT0 will become an indicator for loss of PLL lock (LOSS\_LOCK).

GOUT1 pin will become an indicator for loss of the selected clock (LOSS\_CLKIN).

PLL0 itself only has four different configurations to choose from but in this mode, it borrows two configurations (Config2 and Config3) from both PLL1 and PLL2, to provide eight different stored configurations. PLL1 and PLL2 will still be fully operational but the default configuration will be Config0. The output banks will each have two P configurations that can be associated with each of the PLL configurations. Each of the two P configurations has its own set of PM bits (See the PRE-SCALERS, FEEDBACK-DIVIDERS, POST-DIVIDERS section for more detail on the PM bits). Use the ODIV bit to choose which post-divider configuration to associate with a specific PLL configuration. For example, if ODIV0\_CONFIG0=1, then when Config0 is selected Qx[9:0]\_CONFIG1 is selected as the post-divider value to be used. Or if ODIV2\_CONFIG3=0, then when CONFIG7 is selected, Qx[9:0]\_CONFIG0 is selected. Note that there is an ODIVx bit for each of the PLL configurations. In this way, the post-divider values can change with the configuration.

To enter this mode, users must set MFC bit to "1", and I<sup>2</sup>C/JTAG pin must be left floating.

GIN2 Pin	GIN1 Pin	GIN0 Pin	PLL0 Configuration Selection (Mode 1)
0	0	0	Configuration 0: D0_CONFIG0, M0_CONFIG0, and ODIV0_CONFIG0
0	0	1	Configuration 1: D0_CONFIG1, M0_CONFIG1, and ODIV0_CONFIG1
0	1	0	Configuration 2: D0_CONFIG2, M0_CONFIG2, and ODIV0_CONFIG2
0	1	1	Configuration 3: D0_CONFIG3, M0_CONFIG3, and ODIV0_CONFIG3
1	0	0	Configuration 4: D1_CONFIG2, M1_CONFIG2, and ODIV1_CONFIG2
1	0	1	Configuration 5: D1_CONFIG3, M1_CONFIG3, and ODIV1_CONFIG3
1	1	0	Configuration 6: D2_CONFIG2, M2_CONFIG2, and ODIV2_CONFIG2
1	1	1	Configuration 7: D2_CONFIG3, M2_CONFIG3, and ODIV2_CONFIG3

### MODE2 - Manual Frequency Control (MFC) Mode for all PLLs

In this mode, the configuration of PLL0, PLL1, and PLL2 can be changed during operation. The GINx pins are used to control the selection of up to four different Dx, Mx, P, RZx, CZx, CPx, and IPx configurations for each PLL. GIN0 and GIN1 become configuration selection pins for D0 and M0 of PLL0, GIN2 and GIN3 become configuration selection pins for D1 and M1 of PLL1, and GIN4 and GIN5 become configuration selection pins for D2 and M2 of PLL2. The output GOUT0 will become an indicator for loss of PLL lock (LOSS\_LOCK). GOUT1 pin will become an indicator for loss of the selected clock (LOSS\_CLKIN).

The output banks will have two different P configurations to choose from for each of the four PLL configurations. Each of the two P configurations has its own set of PM bits (See the PRE-SCALERS, FEEDBACK-DIVIDERS, POST-DIVIDERS section for more detail on the PM bits). Use the ODIV bit to choose which post-divider configuration to associate with a specific PLL configuration. For example, if ODIV2\_CONFIG2=1, then when Config2 is selected Qx[9:0]\_CONFIG1 is selected as the post-divider value to be used. Note that there is an ODIVx bit for each of the PLL configurations. In this way, the post-divider values can change with the configuration.

To enter this mode, users must set MFC bit to "0", and I<sup>2</sup>C/JTAG pin must be left floating.

GIN1 Pin	GIN0 Pin	PLL0 Configuration Selection (Mode 2)
0	0	Configuration 0
0	1	Configuration 1
1	0	Configuration 2
1	1	Configuration 3

GIN5 Pin	GIN4 Pin	PLL2 Configuration Selection (Mode 2)
0	0	Configuration 0
0	1	Configuration 1
1	0	Configuration 2
1	1	Configuration 3

GIN3 Pin	GIN2 Pin	PLL1 Configuration Selection (Mode 2)
0	0	Configuration 0
0	1	Configuration 1
1	0	Configuration 2
1	1	Configuration 3

### MODE3 - I<sup>2</sup>C Programming Mode

In this mode, GIN0, GIN1, GIN3 and GIN5 become SDAT (I<sup>2</sup>C data), SCLK (I<sup>2</sup>C clock), SUSPEND and CLK\_SEL signal pins, respectively. The output GOUT0 will become an indicator for loss of PLL lock (LOSS\_LOCK). GOUT1 pin will become an indicator for loss of the selected clock (LOSS\_CLKIN). GIN2 and GIN4 are not available to users.

To enter this mode, I<sup>2</sup>C/JTAG pin must be set HIGH.

### MODE4 - JTAG Programming Mode

In this mode, GIN0, GIN1, GIN2, GIN3, GIN4 and GIN5 will become TDI (JTAG data in), TCK (JTAG clock), TMS (JTAG control signal), SUSPEND,  $\overline{\text{TRST}}$  (JTAG reset) and CLK\_SEL signal pins, respectively. The output GOUT0 will become JTAG TDO signal, and GOUT1 will be an indicator for loss of the selected clock (LOSS\_CLKIN).

To enter this mode, I<sup>2</sup>C/JTAG pin must be set LOW.

Multi-Purpose pins	Manual Frequency Control modes			
	Mode1	Mode2	JTAG	I <sup>2</sup> C
GIN0	GIN0	GIN0	TDI	SDAT
GIN1	GIN1	GIN1	TCK	SCLK
GIN2	GIN2	GIN2	TMS	n/a
GIN3	SUSPEND	GIN3	SUSPEND	SUSPEND
GIN4	n/a	GIN4	$\overline{\text{TRST}}$	n/a
GIN5	CLK_SEL	GIN5 <sup>(1)</sup>	CLK_SEL	CLK_SEL
GOUT0	LOSS_LOCK	LOSS_LOCK	TDO	LOSS_LOCK
GOUT1	LOSS_CLKIN	LOSS_CLKIN	LOSS_CLKIN	LOSS_CLKIN

**NOTE:**

- The PLL(s) will lock onto the primary clock and the manual switchover can be controlled by the PRIMCLK bit.

### Understanding the GIN Signals

During power up, the part will virtually be in MFC mode2, therefore, the values of GIN4, GIN3, GIN2, GIN1 and GIN0 will be latched and used for PLL configuration selection, regardless of the state of the I<sup>2</sup>C/JTAG pin. GIN5 is not latched, and will assume the LOW state internally when in programming mode. This means that when in programming mode, the PLL configuration can only be changed by writing directly to the registers of the currently selected configuration. When in MFC mode 2, configuration 0 or 1 (GIN5=0) should be selected if you do not want to change configurations when entering or leaving programming mode. The GIN pins should be held LOW during power up to select configuration0 as default.

When not in programming mode, the GIN inputs directly control the selected configuration. The internal GINx signals can be individually disabled via programming the GINEN bits (0x06). When disabled by setting GINENx to "0", the GINx inputs may be left floating, but during power up, the GIN pins will still latch. Disabled inputs are interpreted as LOW by the internal state machines. Even if disabled, GIN2, GIN1, GIN0 and GIN4 pins will be enabled if required for I<sup>2</sup>C or JTAG programming functions when in programming mode. The SUSPEND and CLK\_SEL functions on the GIN3 and GIN5 pins, respectively, will be rendered completely non-functional when disabled.

## SHUTDOWN/SUSPEND/ENABLE OF OUTPUTS

There are two external pins along with internal bits that control the enabling/disabling of the output banks. The two pins are the SHUTDOWN/OE pin and the GIN3/SUSPEND pin. The SHUTDOWN/OE pin can be programmed to function as an output enable or global shutdown. The polarity of the SHUTDOWN/OE signal pin can be programmed to be either active HIGH or LOW with the SP bit (0x1C). When SP is "0", the pin becomes active HIGH and when SP is "1", the pin becomes active LOW. The SH bit(0x1C) determines the function of the SHUTDOWN/OE signal pin. If SH is "1", the signal pin is SHUTDOWN and functions as a global shutdown. This will override the OEx (0x1C), OSx (0x1D), and PLLSx (0x1E) bits. If SH is "0", the signal pin is OE and functions as an enable/disable of the output banks. If used as an output enable/disable, each output bank can be individually programmed to be enabled or disabled by the OE pin by setting OEx bits to "1". If the OE signal pin is asserted, the output banks that has their corresponding OEx bit set to "1" will be disabled. The OEMx bits determine the outputs' disable state. When set to "0x" the outputs will be tristated. When set to "10", the outputs will be pulled low. When set to "11", the outputs will be pulled high. Inverted outputs will be parked in the opposite state. If the OEx bits are set to "0", the states of the corresponding output banks will not be impacted by the state of the OE pin. To individually enable/disable via programming instead of the OE pin, hard wire the OE pin to Vdd or GND (depending if it is active HIGH or LOW) as if to disable the outputs. Then toggle the OEx bits to either "0" to enable or "1" to disable.

When the chip is in shutdown, the outputs, the reference oscillator, and the I<sup>2</sup>C/JTAG pin are powered down. The outputs will be tristated and the I<sup>2</sup>C/JTAG pin will be set to MFC mode (MID level). Programming will not be allowed. The GINx pins and clock inputs remain operational. The PLL is not disabled. The SHUTDOWN pin must be reasserted in order to program the part or to resume operation.

The GIN3/SUSPEND pin, when used as a SUSPEND function, can be used to power down the PLL and/or output banks. Each output bank can be individually programmed to be enabled or disabled by the SUSPEND signal pin by setting the OSx bits to "1". If the SUSPEND signal pin is asserted, the output banks that has their corresponding OSx bit set to "1" will be powered down and outputs tristated. If the OSx bits are set to "0", the states of the corresponding output banks will not be impacted by the state of the SUSPEND pin. There is also an option to suspend individual PLLs by setting the PLLSx bits (0x1E) to "1". This will associate the PLL to the SUSPEND pin. When the pin is asserted, the corresponding PLLs will be powered down. It will not only power down the PLL but also any output bank associated with it. The PLLSx bits will override the OSx bits.

In the event of a PLL suspend, the PLL must achieve lock again after it has been re-enabled, In the event of a global shutdown, the PLL does not have to re-acquire lock since it is not disabled.

## MANUAL FREQUENCY CONTROL (MFC) BLOCK DIAGRAM

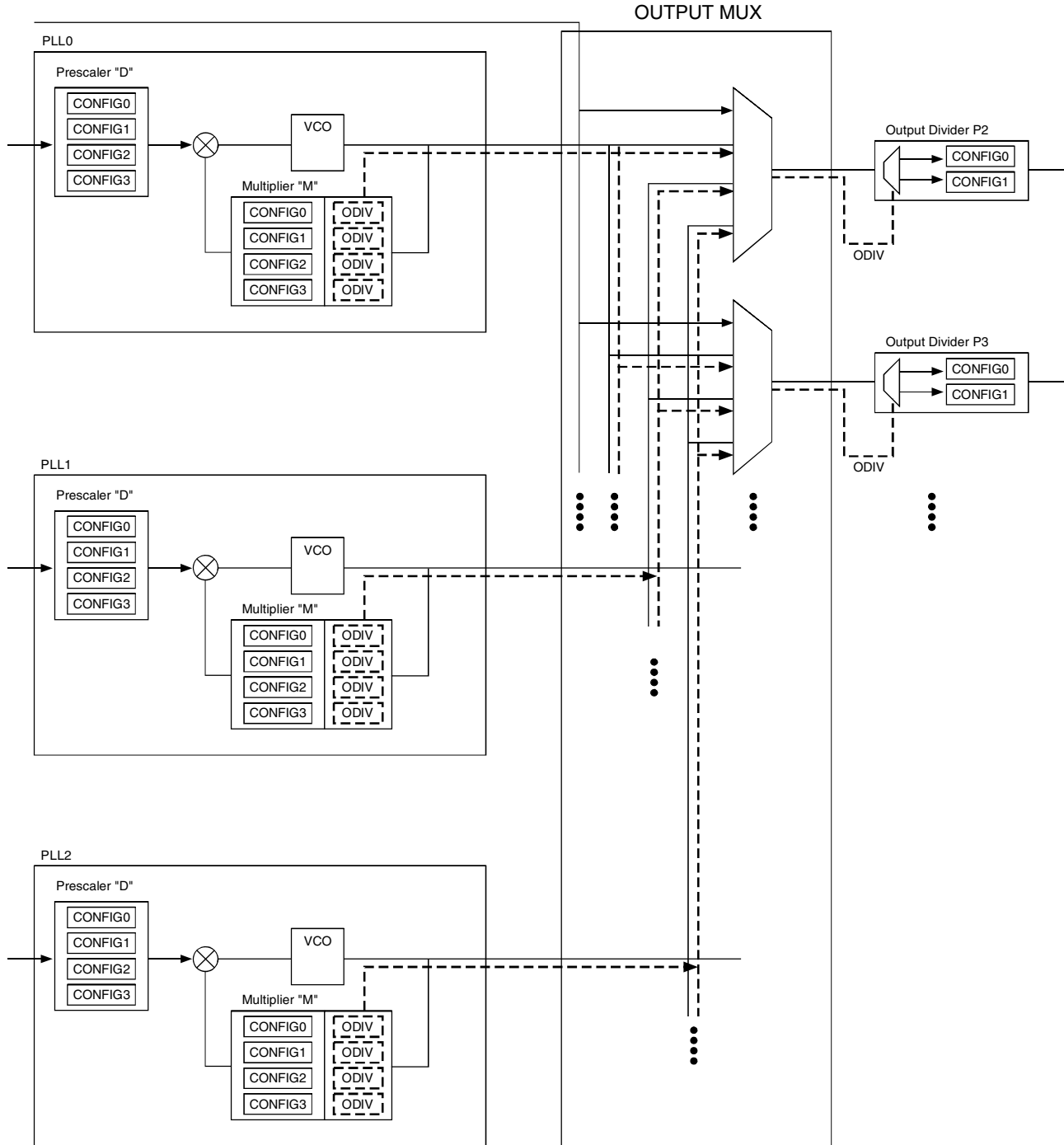

MFC = 0

### NOTES:

This illustration shows how the configurations are arranged for each PLL. There is an ODIV bit associated with each of the four configurations.

- GIN0 and GIN1 control four configurations from PLL0.
- GIN2 and GIN3 control four configurations from PLL1.
- GIN4 and GIN4 control four configurations from PLL2.
- ODIV from each configuration determines the selection of two Output Divider Px Configurations.

## MANUAL FREQUENCY CONTROL (MFC) BLOCK DIAGRAM

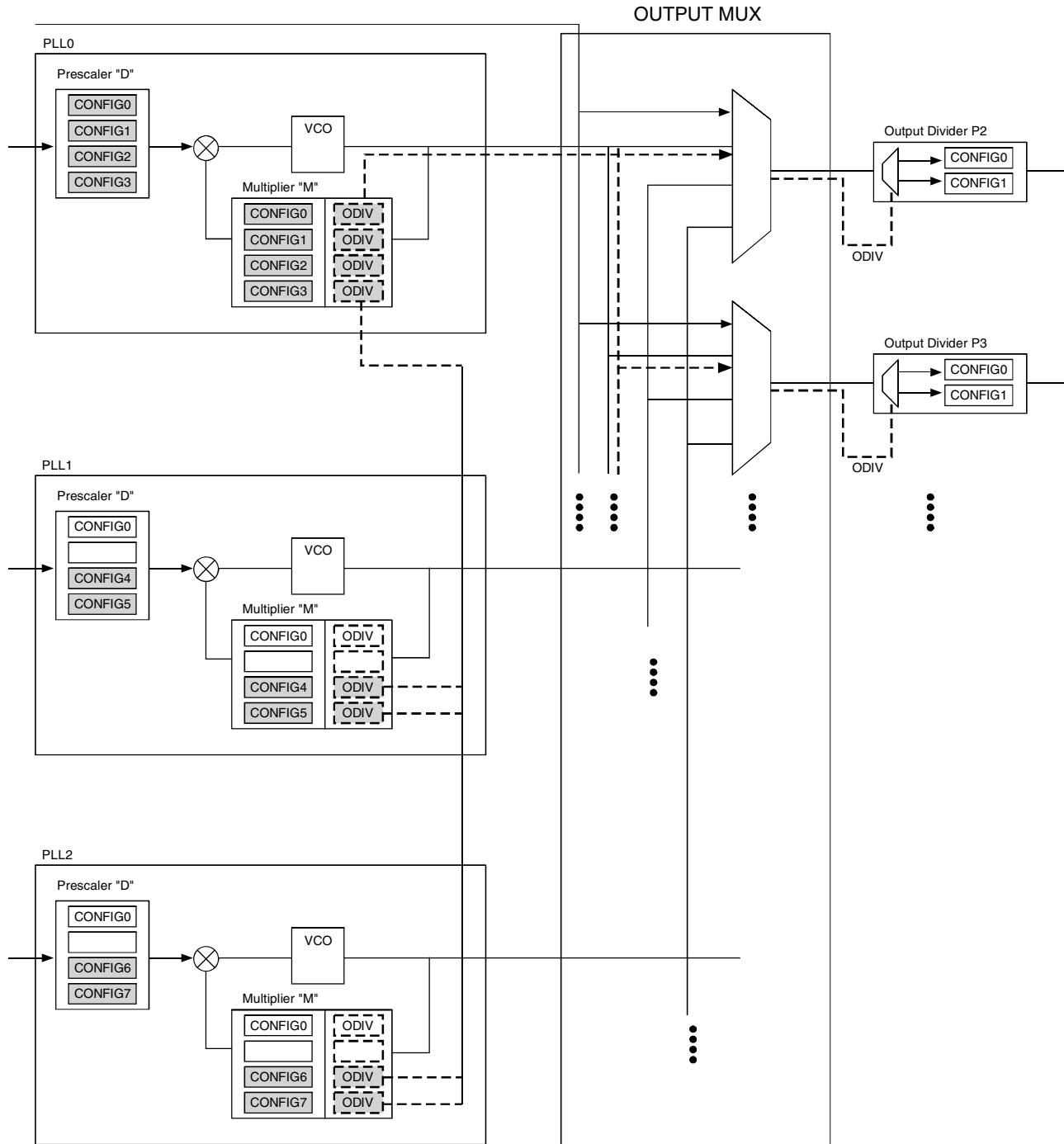

MFC = 1

### NOTES:

This illustration shows how the configurations are arranged for PLL0. Config\_4 and Config\_5 are taken from PLL1, and Config\_6 and Config\_7 are taken from PLL2. There is an ODIV bit associated with each of the four configurations.

- GIN0, GIN1, and GIN2 control eight shaded configurations for PLL0.
- ODIV from each configuration determines the selection of two Output Divider Px Configurations.

BLOCK DIAGRAM FOR SHUTDOWN/OE CONTROL SIGNAL

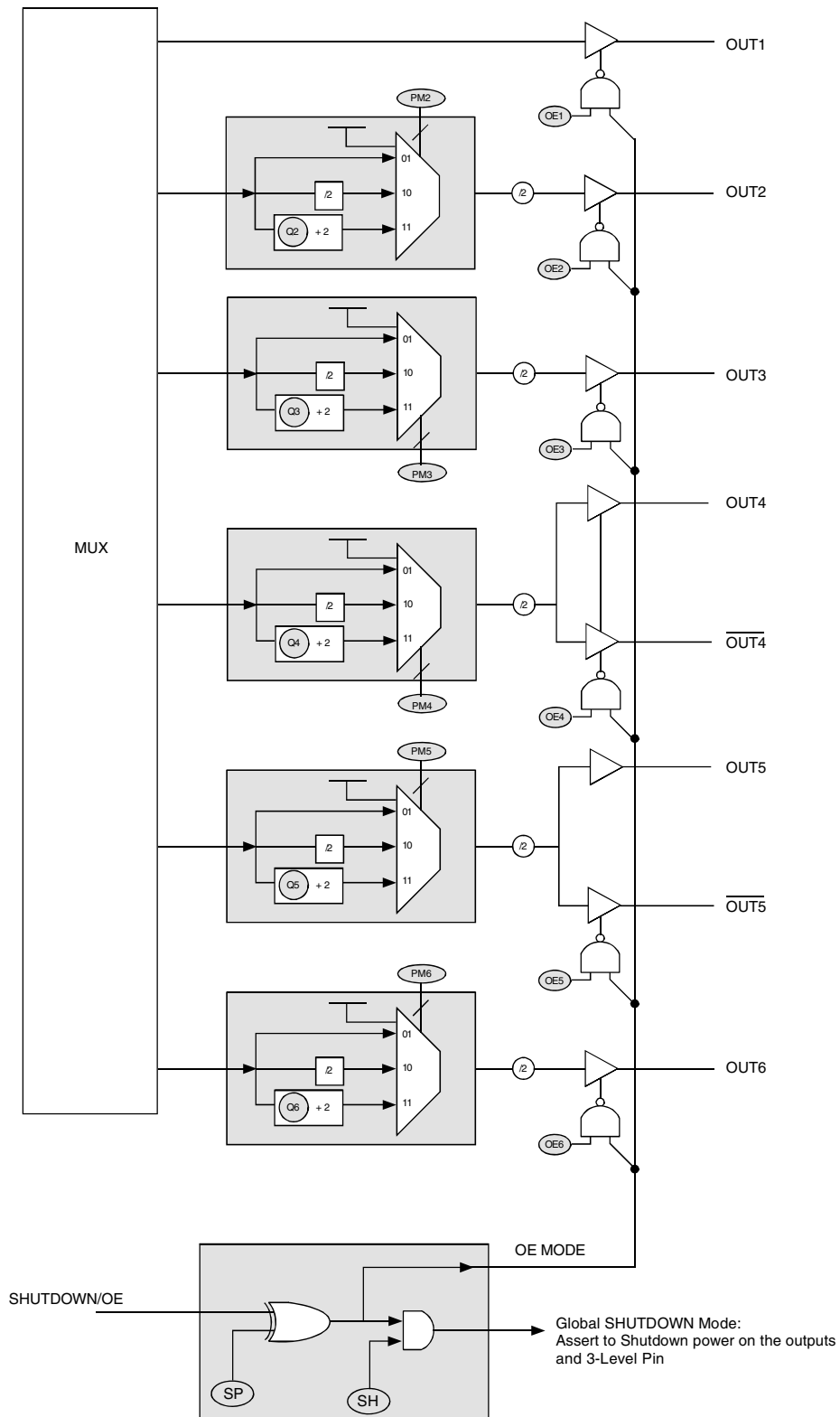

**NOTE:**  
This illustration shows the internal logic behind the SHUTDOWN/OE pin and the bits associated with it.

## POWER UP AND POWER SAVING FEATURES

If a global shutdown is enabled, SHUTDOWN pin asserted, most of the chip except for the PLLs will be powered down. In order to have a complete power down of the chip, the PLLs must be powered down via the SUSPEND function or by setting the pre-scaler bits to '0x00' and disable the internal GINx signals via the enable bits at memory address 0x05. Note that the register bits will not lose their state in the event of a chip power-down. The only possibility that the register bits will lose their state is if the part was power-cycled. After coming out of shutdown mode, the PLLs will require time to relock.

During power up, the values of GIN4, GIN3, GIN2, GIN1 and GIN0 will be latched and used for PLL configuration selection, regardless of the state of the I<sup>2</sup>C/JTAG pin and GINx being disabled via the GINENx bits. GIN5 will have an internal state of LOW. The GIN pins should be held LOW during power up to select configuration 0 as default. The output levels will be at an undefined state during power up.

The post-divider should never be disabled via PM bits after power up, or else it will render the output bank completely non-functional during normal operation, (unless the output bank itself will not be used at all).

## LOSS OF LOCK AND INPUT CLOCK

The device employs a loss of lock and loss of input clock detection circuitry. The GIN0/LOSS\_LOCK and GIN1/LOSS\_CLKIN are the outputs that indicate such failures. LOSS\_LOCK signal will be asserted if any of the three powered up PLLs loses frequency lock for any event other than PLL shutdown. LOSS\_LOCK signal is deasserted after all the active PLLs have acquired lock. Lock is determined by checking that the reference and feedback clocks are within 1/2 period of each other. LOSS\_LOCK is also asserted for at least two clock cycles of the newly selected clock when switching over to a different clock source (manual or automatic). The LOSS\_LOCK detector is jitter sensitive and can only tolerate an amount within the period of the VCO clock. Therefore, it is not recommended for use as a loss of lock indicator in a system where the input jitter is relatively high.

LOSS\_CLKIN is asserted for two clock cycles when the currently selected clock is lost or is asserted (> 2 cycles, since there are no 'cycles') when both clocks are lost. In the event of the selected clock being absent up on power up, the loss of the selected clock detection circuitry will reference an internal oscillator.

## SWITCHOVER MODES

The IDT5V9885 features redundant clock inputs which supports both Automatic and Manual switchover mode. These two modes are determined by the configuration bits, SM (0x34). The primary clock source can be programmed, via the PRIMCLK bit, to be either XTALIN/REFIN or CLKIN, which is determined by the PRIMCLK bit. The other clock source input will be considered as the secondary source. This is more detailed in the 'REFERENCE CLOCK INPUT PINS AND SELECTION'. Note that the switchover modes are asynchronous. If the reference clocks are directly routed to OUTx with no phase relationship, short pulses can be generated during switchover.

### MANUAL SWITCHOVER MODE

When SM[1:0] is "0x", the redundant inputs are in manual switchover mode. In this mode, CLK\_SEL pin is used to switch between the primary and secondary clock sources. As previously mentioned, the primary and secondary clock source setting is determined by the PRIMCLK bit. During the switchover, no glitches will occur at the output of the device, although there may be frequency and phase drift, depending on the exact phase and frequency relationship between the primary and secondary clocks. The LOSS\_LOCK signal will be asserted for a minimum of two input clock cycles of the newly selected clock, even if the two inputs are exactly in phase. GOUT1 is used as LOSS\_CLKIN, which indicates the loss of the currently used selected clock.

### AUTOMATIC SWITCHOVER MODE

When SM[1:0] is "1x", the redundant inputs are in automatic switchover mode. Automatic switchover mode supports both revertive and non-revertive functionalities. These two functions are determined by the SM bits being set to "10" for non-revertive and "11" for revertive.

#### *Non-Revertive*

The input clock selection will switch to the secondary clock source when there are no transitions on the primary clock source for two secondary clock cycles. LOSS\_LOCK and LOSS\_CLKIN signals will be asserted for a minimum of two secondary clock cycles. LOSS\_LOCK will remain asserted until the PLL achieves lock, as previously defined, to the new input clock. If there are no transitions on both clock sources, the LOSS\_LOCK signal and LOSS\_CLKIN signal will be asserted. In this mode, once the secondary clock is selected, it will not automatically re-select the primary clock as the input clock, even if the secondary clock goes away and the primary clock is functional. The CLK\_SEL pin must be toggled to re-select the primary clock source as the input clock.

*Revertive*

The input clock selection will switch to the secondary clock source when there are no transitions on the primary clock source for two secondary clock cycles. LOSS\_LOCK and LOSS\_CLKIN signals will be asserted for a minimum of two input clock cycles of the newly selected clock. LOSS\_LOCK will remain asserted until the PLL achieves lock, as previously defined, to the new input clock. If there are no transitions on both clock sources, the LOSS\_LOCK signal and LOSS\_CLKIN signal will be asserted. After a stable and valid primary clock source is present for either 8 or 1024 primary clock cycles, the input clock selection will automatically switch back to the primary clock source and LOSS\_CLKIN signal will be deasserted. The CLK\_SEL pin can be left floating in this auto-revertive mode. The OKC bit (0x1D) determines the number of valid primary clock cycles of either 8 or 1024 before switching back to the primary clock source. If OKC is set to "0", the primary clock will be re-selected as the input clock if the primary clock is present for 8 primary clock cycles. If OKC is set to "1", the re-select threshold is 1024 primary clock cycles. Note that both clock inputs must be at the same frequency in order for the auto-revertive switchover to function properly. If both reference clocks are at different frequencies, the device will always remain on the primary clock unless it is absent for two secondary clock cycles.

In all switchover modes, LOSS\_LOCK signal is asserted for at least two input clock cycles of the newly selected clock when switching clock sources (manually or automatic).

## CLOCK SWITCH MATRIX AND OUTPUTS

All three PLL outputs and the currently selected input clock source are routed into and through a clock matrix. The user is able to select which PLL output and clock source is routed to which output bank via the SRCx bits (0x34, 0x35). Each output bank has its own set of SRC bits. Refer to the RAM table for more information. Note that OUT1 will be based off the reference clock and the only output bank toggling under the default RAM bit settings.

Outputs 1, 2 and 3 are 3.3V LVTTTL. Outputs banks 4 and 5 can be 3.3V LVTTTL, LVPECL or LVDS. The LVDS and LVPECL selection is determined by the LVLx bits (0x54, 0x58). Each output bank has individual slew-rate control (SLEWx bits). Each output can be individually inverted (INVx bits); when using LVPECL or LVDS modes, one of the outputs in each LVPECL/LVDS pair should be inverted. All output banks except OUT1 have a programmable 10-bit post-divider (Qx bits) with two selectable divide configurations via the ODIVx bits.

There are four settings for the programmable slew rate, 0.7V/ns, 1.25V/ns, 2V/ns, and 2.75V/ns; this only applies to the 3.3V LVTTTL outputs. The differential outputs are not slew rate programmable in LVPECL or LVDS modes. SLEW4 and/or SLEW5 must be set to 2.75V/ns for stable output operation. For LVTTTL output frequency rates higher than 100MHz, a slew rate of 2V/ns or greater should be selected. The post-dividers can be disabled using the PMx bit, which is described in the PRE-SCALER, FEEDBACK-DIVIDER, AND POST-DIVIDER section. Each output can also be enabled/disabled, which is described in the 'SHUTDOWN/SUSPEND/ENABLE of OUTPUTS' section. Refer to the RAM table for all binary settings.

## HIGH LEVEL BLOCK DIAGRAM FOR CONFIGURATION SCHEME

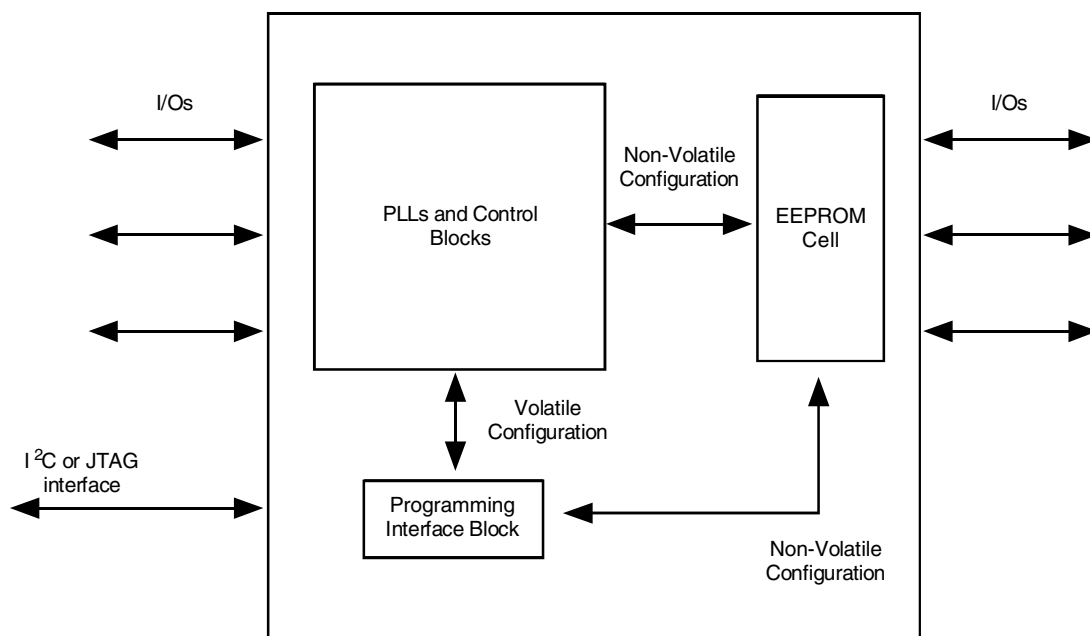

NOTE: Diagram does not represent actual number of die on chip.

## PROGRAMMING THE DEVICE

I<sup>2</sup>C and JTAG may be used to program the 5V9885. The I<sup>2</sup>C/JTAG pin selects the I<sup>2</sup>C when HIGH and JTAG when LOW. Note that the  $\overline{\text{TRST}}$  pin needs to be LOW for I<sup>2</sup>C mode.

### Hardwired Parameters for the IDT5V9885

JTAG identification number = 32'b0000\_0000001110101100\_00000110011\_1

Device (slave) address = 7'b1101010

ID Byte for the 5V9885 = 8'b00010000

### I<sup>2</sup>C PROGRAMMING

The 5v9885 is programmed through an I<sup>2</sup>C-Bus serial interface, and is an I<sup>2</sup>C slave device. The read and write transfer formats are supported. The first byte of data after a write frame to the correct slave address is interpreted as the register address; this address auto-increments after each byte written or read. The frame formats are shown below.

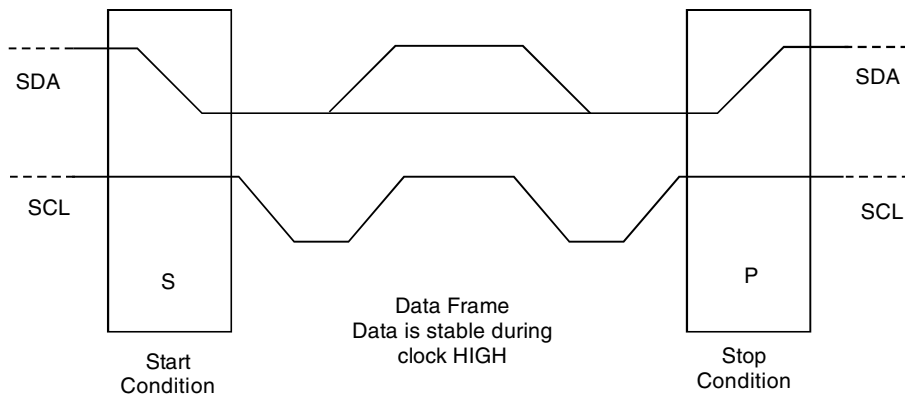
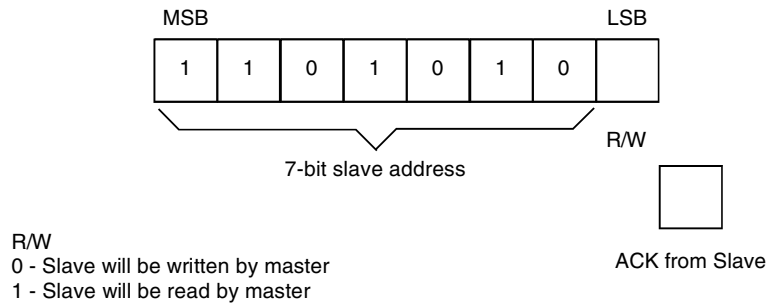

Figure 1: Framing

Each frame starts with a "Start Condition" and ends with an "End Condition". These are both generated by the Master device.



The first byte transmitted by the Master is the Slave Address followed by the R/W bit. The Slave acknowledges by sending a "1" bit.

Figure 2: First Byte Transmitted on I<sup>2</sup>C Bus

**EXTERNAL I<sup>2</sup>C INTERFACE CONDITION**

**KEY:**

 From Master to Slave

 From Master to Slave, but can be omitted if followed by the correct sequence  
Normally data transfer is terminated by a STOP condition generated by the Master. However, if the Master still wishes to communicate on the bus, it can generate a repeated START condition, and address another Slave address without first generating a STOP condition.

 From Slave to Master

**SYMBOLS:**

- ACK - Acknowledge (SDA LOW)
- NACK - Not Acknowledge (SDA HIGH)
- Sr - Repeated Start Condition
- S - START Condition
- P - STOP Condition

**PROGWRITE**



S	Address	R/W	ACK	Command Code	ACK	Register	ACK	Data	ACK	P
	7-bits	0	1-bit	8-bits: xxxxxx00	1-bit	8-bits	1-bit	8-bits	1-bit	

*Figure 3: Progwrite Command Frame*

Writes can continue as long as a Stop condition is not sent and each byte will increment the register address.

**PROGREAD**

Note: If the expected read command is not from the next higher register to the previous read or write command, then set a known "read" register address prior to a read operation by issuing the following command:

S	Address	R/W	ACK	Command Code	ACK	Register	ACK	 P
	7-bits	0	1-bit	8-bits: xxxxxx00	1-bit	8-bits	1-bit	

*Figure 4a: Prior to Progreed Command Set Register Address*

The user can ignore the STOP condition above and use a repeated START condition instead, straight after the slave acknowledgement bit (i.e., followed by the Progreed command):

Sr	Address	R/W	ACK	ID Byte	ACK	Data_1	ACK	Data_2	ACK	Data_last	NACK	P
	7-bits	1	1-bit	8 bits	1-bit	8-bits	1-bit	8-bits	1-bit	8-bits	1-bit	

*Figure 4b: Progreed Command Frame*

Note: Figure 4b above by itself is the Progreed command format. The ID byte for the 5V9885 is 10hex. Each byte recieved increments the register address.

**PROGSAVE**

S	Address	R/W	ACK	Command Code	ACK	P
	7-bits	0	1-bit	8-bits:xxxxxx01	1-bit	

**NOTE:**  
 PROGWRITE is for writing to the 5v9885 registers.  
 PROGREAD is for reading the 5v9885 registers.  
 PROGSAVE is for saving all the contents of the 5v9885 registers to the EEPROM.  
 PROGRESTORE is for loading the entire EEPROM contents to the 5v9885 registers.

**PROGRESTORE**

S	Address	R/W	ACK	Command Code	ACK	P
	7-bits	0	1-bit	8-bits:xxxxxx10	1-bit	

**JTAG INTERFACE**

In addition to the IEEE 1149.1 instructions EXTEST, SAMPLE/PRELOAD, CLAMP, HIGH-Z and BYPASS, the 5V9885 allows access to internal programming registers using the REGADDR (set register address), REGDATAR (read register) and REGDATW (write register instructions. Data is always accessed by byte, and the register address increments after each read or write. The full instruction set follows. The IDT5V9885 will be updating the registers during programming.

The JTAG TAP controller can be reset in one of four ways:

- 1) Power up in JTAG mode
- 2) Power up in I<sup>2</sup>C mode and then go into JTAG mode, or go out of and back into JTAG mode with the I<sup>2</sup>C/JTAG pin
- 3) Apply TRST while in JTAG mode
- 4) Apply five rising edges of TCK with TMS high while in JTAG mode

**JTAG INSTRUCTION REGISTER DESCRIPTION**

IR (3)	IR (2)	IR (1)	IR (0)	Instructions
0	0	0	0	EXTEST <sup>(1)</sup>
0	0	0	1	SAMPLE/PRELOAD <sup>(1)</sup>
0	0	1	0	IDCODE <sup>(1)</sup>
0	0	1	1	REGADDR <sup>(2)</sup>
0	1	0	0	REGDATAW / PROGWRITE <sup>(3)</sup>
0	1	0	1	REGDATAR / PROGREAD <sup>(4)</sup>
0	1	1	0	PROGSAVE <sup>(5)</sup>
0	1	1	1	PROGRESTORE <sup>(6)</sup>
1	0	0	0	CLAMP <sup>(1)</sup>
1	0	0	1	HIGHZ <sup>(1,7)</sup>
1	1	1	1	BYPASS <sup>(1)</sup>

- NOTES:**
1. IEEE 1149.1 definition
  2. REGADDR is for setting a specific 5v9885 register address.
  3. REGDATAW/PROGWRITE is for writing to the 5v9885 registers.
  4. REGDATAR/PROGREAD is for reading the 5v9885 registers.
  5. PROGSAVE is for saving all the contents of the 5v9885 registers to the EEPROM.
  6. PROGRESTORE is for loading the entire EEPROM contents to the 5v9885 registers.
  7. The OEMs bits for OUT1-6 must be set for tri-state when using the HIGHZ instruction

**EEPROM INTERFACE**

The IDT5V9885 can also store its configuration in an internal EEPROM. The contents of the device's internal programming registers can be saved to the EEPROM by issuing a save instruction (ProgSave) and can be loaded back to the internal programming registers by issuing a restore instruction (ProgRestore).

To initiate a save or restore using I<sup>2</sup>C, only two bytes are transferred. The Device Address is issued with the read/write bit set to "0", followed by the appropriate command code. The save or restore instruction executes after the STOP condition is issued by the Master, during which time the IDT5V9885 will not generate Acknowledge bits. The 5V9885 will acknowledge the instructions after it has completed execution of them. During that time, the I<sup>2</sup>C bus should be interpreted as busy by all other users of the bus.

Using JTAG, the ProgSave and ProgRestore instructions selects the BYPASS register path for shifting the data from TDI to TDO during the data register scanning. During the execution of a ProgSave or ProgRestore instruction, the IDT5V9885 will not accept a new programming instruction (read, write, save, or restore). All non-programming JTAG instructions will function properly, but the user should wait until the save or restore is complete before issuing a new programming instruction. If a new programming instruction is issued before the save or restore completes, the new instruction is ignored, and the BYPASS register path remains in effect for shifting data from TDI to TDO during data register scanning.

The time it takes for the save (T<sub>SAVE</sub>) and restore (T<sub>RESTORE</sub>) instructions to complete can be calculated as follows:

$$T_{SAVE}/T_{RESTORE} = 128 \text{ bytes} * 8 \text{ bits/byte} * 1/300\text{KHz} + \text{overhead (ms)}$$

In order for the save and restore instructions to function properly, the IDT5V9885 must not be in shutdown mode (SHUTDOWN pin asserted). In the event of an interrupt of some sort such as a power down of the part in the middle of a save or restore operation, the contents to or from the EEPROM will be partially loaded, and a CRC error will be generated. The CERR bit (0x81) will be asserted to indicate that an error has occurred. The LOSS\_LOCK signal will also be asserted.

On power-up of the IDT5V9885, an automatic restore is performed to load the EEPROM contents into the internal programming registers. The auto-restore will not function properly if the device is in shutdown mode (SHUTDOWN pin asserted). The IDT5V9885 will be ready to accept a programming instruction once it acknowledges its 7-bit I<sup>2</sup>C address.

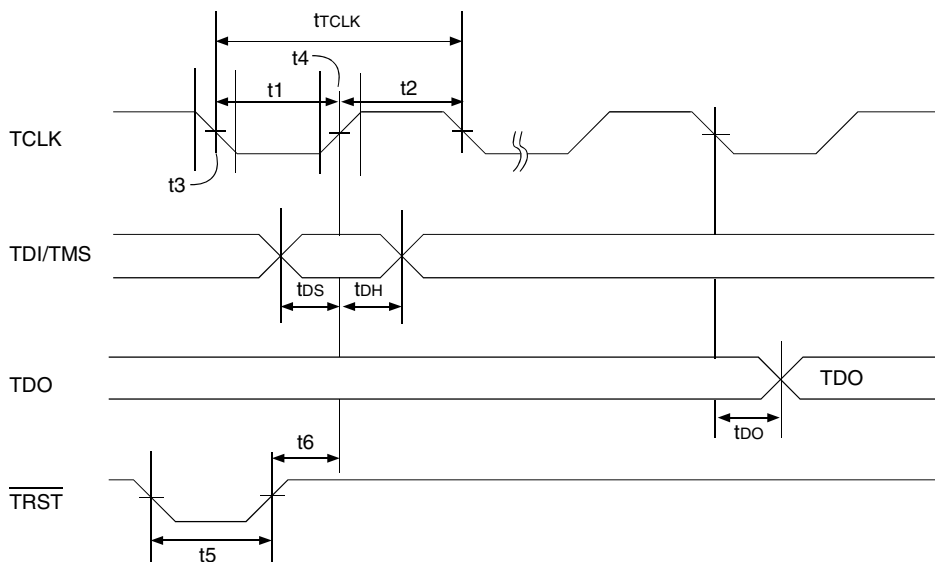

Standard JTAG Timing

**NOTE:**

- t1 = t<sub>TCLKLOW</sub>
- t2 = t<sub>TCLKHIGH</sub>
- t3 = t<sub>TCLKFALL</sub>
- t4 = t<sub>TCLKRISE</sub>
- t5 = t<sub>TRST</sub> (reset pulse width)
- t6 = t<sub>TRSR</sub> (reset recovery)

JTAG  
AC ELECTRICAL CHARACTERISTICS

Symbol	Parameter	Min.	Max.	Units
t <sub>TCLK</sub>	JTAG Clock Input Period	100	—	ns
t <sub>TCLKHIGH</sub>	JTAG Clock HIGH	40	—	ns
t <sub>TCLKLOW</sub>	JTAG Clock Low	40	—	ns
t <sub>TCLKRISE</sub>	JTAG Clock Rise Time	—	5 <sup>(1)</sup>	ns
t <sub>TCLKFALL</sub>	JTAG Clock Fall Time	—	5 <sup>(1)</sup>	ns
t <sub>TRST</sub>	JTAG Reset	50	—	ns
t <sub>TRSR</sub>	JTAG Reset Recovery	50	—	ns

**NOTE:**

- 1. Guaranteed by design.

SYSTEM INTERFACE PARAMETERS

Symbol	Parameter	Min.	Max.	Units
t <sub>DO</sub>	Data Output <sup>(1)</sup>	—	20	ns
t <sub>DOH</sub>	Data Output Hold <sup>(1)</sup>	0	—	ns
t <sub>DS</sub>	Data Input, t <sub>RISE</sub> = 3ns	10	—	ns
t <sub>DH</sub>	Data Input, t <sub>FALL</sub> = 3ns	10	—	ns

**NOTE:**

- 1. 50pF loading on external output signals.

## I<sup>2</sup>C BUS DC CHARACTERISTICS

Symbol	Parameter	Conditions	Min	Typ	Max	Unit
V <sub>IH</sub>	Input HIGH Level		0.7 * V <sub>DD</sub>			V
V <sub>IL</sub>	Input LOW Level				0.3 * V <sub>DD</sub>	V
V <sub>HYS</sub>	Hysteresis of Inputs		0.05 * V <sub>DD</sub>			V
I <sub>IN</sub>	Input Leakage Current				±1.0	µA
V <sub>OL</sub>	Output LOW Voltage	I <sub>OL</sub> = 3 mA			0.4	V

## I<sup>2</sup>C BUS AC CHARACTERISTICS FOR STANDARD MODE

Symbol	Parameter	Min	Typ	Max	Unit
F <sub>SCLK</sub>	Serial Clock Frequency (SCLK)	0		100	KHz
t <sub>BUF</sub>	Bus free time between STOP and START	4.7			µs
t <sub>SU:START</sub>	Setup Time, START	4.7			µs
t <sub>HD:START</sub>	Hold Time, START	4			µs
t <sub>SU:DATA</sub>	Setup Time, data input (SDAT)	250			ns
t <sub>HD:DATA</sub>	Hold Time, data input (SDAT) <sup>(1)</sup>	0			µs
t <sub>OVd</sub>	Output data valid from clock			3.45	µs
C <sub>B</sub>	Capacitive Load for Each Bus Line			400	pF
t <sub>r</sub>	Rise Time, data and clock (SDAT, SCLK)			1000	ns
t <sub>f</sub>	Fall Time, data and clock (SDAT, SCLK)			300	ns
t <sub>HIGH</sub>	HIGH Time, clock (SCLK)	4			µs
t <sub>LOW</sub>	LOW Time, clock (SCLK)	4.7			µs
t <sub>SU:STOP</sub>	Setup Time, STOP	4			µs

**NOTE:**  
1. A device must internally provide a hold time of at least 300ns for the SDAT signal (referred to the V<sub>IHMIN</sub> of the SCLK signal) to bridge the undefined region of the falling edge of SCLK.

## I<sup>2</sup>C BUS AC CHARACTERISTICS FOR FAST MODE

Symbol	Parameter	Min	Typ	Max	Unit
F <sub>SCLK</sub>	Serial Clock Frequency (SCLK)	0		400	KHz
t <sub>BUF</sub>	Bus free time between STOP and START	1.3			µs
t <sub>SU:START</sub>	Setup Time, START	0.6			µs
t <sub>HD:START</sub>	Hold Time, START	0.6			µs
t <sub>SU:DATA</sub>	Setup Time, data input (SDAT)	100			ns
t <sub>HD:DATA</sub>	Hold Time, data input (SDAT) <sup>(1)</sup>	0			µs
t <sub>OVd</sub>	Output data valid from clock			0.9	µs
C <sub>B</sub>	Capacitive Load for Each Bus Line			400	pF
t <sub>r</sub>	Rise Time, data and clock (SDAT, SCLK)	20 + 0.1 * C <sub>B</sub>		300	ns
t <sub>f</sub>	Fall Time, data and clock (SDAT, SCLK)	20 + 0.1 * C <sub>B</sub>		300	ns
t <sub>HIGH</sub>	HIGH Time, clock (SCLK)	0.6			µs
t <sub>LOW</sub>	LOW Time, clock (SCLK)	1.3			µs
t <sub>SU:STOP</sub>	Setup Time, STOP	0.6			µs

**NOTE:**  
1. A device must internally provide a hold time of at least 300ns for the SDAT signal (referred to the V<sub>IHMIN</sub> of the SCLK signal) to bridge the undefined region of the falling edge of SCLK.

## ABSOLUTE MAXIMUM RATINGS<sup>(1)</sup>

Symbol	Description	Max	Unit
V <sub>DD</sub>	Internal Power Supply Voltage	-0.5 to +4.6	V
V <sub>I</sub>	Input Voltage	-0.5 to +4.6	V
V <sub>O</sub>	Output Voltage <sup>(2)</sup>	-0.5 to V <sub>DD</sub> + 0.5	V
T <sub>J</sub>	Junction Temperature	150	°C
T <sub>STG</sub>	Storage Temperature	-65 to +150	°C

### NOTE:

- Stresses greater than those listed under ABSOLUTE MAXIMUM RATINGS may cause permanent damage to the device. This is a stress rating only and functional operation of the device at these or any other conditions above those indicated in the operational sections of this specification is not implied. Exposure to absolute maximum rating conditions for extended periods may affect reliability.
- Not to exceed 4.6V.

## CAPACITANCE (T<sub>A</sub> = +25°C, f = 1MHz, V<sub>IN</sub> = 0V)<sup>(1)</sup>

Symbol	Parameter	Min.	Typ.	Max.	Unit
C <sub>IN</sub>	Input Capacitance	—	4	—	pF

### Crystal Specifications

XTAL_FREQ	Crystal Frequency	8	—	50	MHz
XTAL_MIN	Minimum Crystal Load Capacitance	—	3.5	—	pF
XTAL_MAX	Maximum Crystal Load Capacitance	—	35.4	—	pF
	Crystal Load Capacitance Resolution	—	0.125	—	
XTAL_V <sub>PP</sub>	Voltage Swing (peak-to-peak, nominal)	—	2.3	—	V

### NOTE:

- Capacitance levels characterized but not tested.

## RECOMMENDED OPERATING CONDITIONS

Symbol	Description	Min.	Typ.	Max.	Unit
V <sub>DD</sub> /AV <sub>DD</sub>	Power Supply Voltage for LVTTTL	3	3.3	3.6	V
	Power Supply Voltage for LVDS/LVPECL	3.135	3.3	3.465	
T <sub>A</sub>	Operating Temperature, Ambient	-40	—	+85	°C
C <sub>LOAD_OUT</sub>	Maximum Load Capacitance (LVTTTL only)	—	—	15	pF
F <sub>IN</sub>	External Reference Crystal	8	—	50	MHz
	External Reference Clock, Industrial	1	—	400	
t <sub>PU</sub>	Power-up time for all V <sub>DD</sub> s to reach minimum specified voltage (power ramps must be monotonic)	0.05	—	5	ms

## DC ELECTRICAL CHARACTERISTICS OVER OPERATING RANGE

Symbol	Parameter	Test Conditions	Min.	Typ.	Max.	Unit
V <sub>IHH</sub>	Input HIGH Voltage Level <sup>(1)</sup>	I <sup>2</sup> C/JTAG 3-Level Input	V <sub>DD</sub> - 0.4	—	—	V
V <sub>IMM</sub>	Input MID Voltage Level <sup>(1)</sup>	I <sup>2</sup> C/JTAG 3-Level Input	V <sub>DD</sub> /2 - 0.2	—	V <sub>DD</sub> /2 + 0.2	V
V <sub>ILL</sub>	Input LOW Voltage Level <sup>(1)</sup>	I <sup>2</sup> C/JTAG 3-Level Input	—	—	0.4	V
I <sub>3</sub>	3-Level Input DC Current	V <sub>IN</sub> = V <sub>DD</sub> HIGH Level	—	—	200	μA
		V <sub>IN</sub> = V <sub>DD</sub> /2 MID Level	-50	—	+50	
		V <sub>IN</sub> = GND LOW Level	-200	—	—	
I <sub>DD</sub>	Total Power Supply Current (3.3V Supply, AV <sub>DD</sub> + V <sub>DD</sub> )	2 outputs @166MHz; 4 outputs @ 83MHz	—	120	—	mA
		2 outputs @20MHz; 4 outputs @ 40MHz	—	40	—	
I <sub>DD5</sub>	Total Power Supply Current in Shutdown Mode <sup>(2)</sup>	Global Shutdown Mode (PLLs, dividers, outputs, etc. powered down)	—	2	—	mA

### NOTES:

- These inputs are normally wired to V<sub>DD</sub>, GND, or left floating. If these inputs are switched dynamically after powerup, the function and timing of the outputs may be glitched, and the PLL may require additional t<sub>AO</sub> time before all datasheet limits are achieved.
- Dividers must reload reprogrammed values via power-on reset or terminal count reload in order to ensure low-power mode.

## DC ELECTRICAL CHARACTERISTICS FOR 3.3V LVTTTL<sup>(1)</sup>

Symbol	Parameter	Test Conditions	Min.	Typ.	Max.	Unit
I <sub>OH</sub>	Output HIGH Current	V <sub>OH</sub> = V <sub>DD</sub> - 0.5, V <sub>DD</sub> = 3.3V ± 0.3V	12	24	—	mA
I <sub>OL</sub>	Output LOW Current	V <sub>OL</sub> = 0.5V, V <sub>DD</sub> = 3.3V ± 0.3V	12	24	—	mA
V <sub>IH</sub>	Input Voltage HIGH		2	—	—	V
V <sub>IL</sub>	Input Voltage LOW		—	—	0.8	V
I <sub>IH</sub>	Input HIGH Current	V <sub>IN</sub> = V <sub>DD</sub>	—	—	10	μA
I <sub>IL</sub>	Input LOW Current	V <sub>IN</sub> = 0V	—	—	10	μA
I <sub>ozD</sub>	Output Leakage Current	3-state outputs	—	—	10	μA

### NOTE:

- See RECOMMENDED OPERATING RANGE table.

## POWER SUPPLY CHARACTERISTICS FOR LVTTTL OUTPUTS

Symbol	Parameter	Test Conditions	Typ.	Max	Unit
I <sub>DDQ</sub>	Quiescent V <sub>DD</sub> Power Supply Current	REF = LOW Outputs enabled, All outputs unloaded	6	12	mA
I <sub>DD3</sub>	Dynamic V <sub>DD</sub> Power Supply Current per Output	V <sub>DD</sub> = Max., C <sub>L</sub> = 0pF	40	60	μA/MHz
I <sub>TOT</sub>	Total Power V <sub>DD</sub> Supply Current	F <sub>REFERENCE CLOCK</sub> = 33MHz, C <sub>L</sub> = 15pf	26	40	mA
		F <sub>REFERENCE CLOCK</sub> = 133MHz, C <sub>L</sub> = 15pf	80	120	
		F <sub>REFERENCE CLOCK</sub> = 200MHz, C <sub>L</sub> = 15pf	112	170	

## DC ELECTRICAL CHARACTERISTICS FOR LVDS

Symbol	Parameter	Min.	Typ.	Max	Unit
V <sub>OT (+)</sub>	Differential Output Voltage for the TRUE binary state	247	—	454	mV
V <sub>OT (-)</sub>	Differential Output Voltage for the FALSE binary state	-247	—	-454	mV
Δ V <sub>OT</sub>	Change in V <sub>OT</sub> between Complimentary Output States	—	—	50	mV
V <sub>OS</sub>	Output Common Mode Voltage (Offset Voltage)	1.125	1.2	1.375	V
Δ V <sub>OS</sub>	Change in V <sub>OS</sub> between Complimentary Output States	—	—	50	mV
I <sub>OS</sub>	Outputs Short Circuit Current, V <sub>OUT+</sub> or V <sub>OUT-</sub> = 0V or V <sub>DD</sub>	—	9	24	mA
I <sub>OSD</sub>	Differential Outputs Short Circuit Current, V <sub>OUT+</sub> = V <sub>OUT-</sub>	—	6	12	mA

## POWER SUPPLY CHARACTERISTICS FOR LVDS OUTPUTS<sup>(1)</sup>

Symbol	Parameter	Test Conditions <sup>(2)</sup>	Typ.	Max	Unit
I <sub>DDQ</sub>	Quiescent V <sub>DD</sub> Power Supply Current	REF = LOW Outputs enabled, All outputs unloaded	68	90	mA
I <sub>DDD</sub>	Dynamic V <sub>DD</sub> Power Supply Current per Output	V <sub>DD</sub> = Max., C <sub>L</sub> = 0pF	30	45	μA/MHz
I <sub>TOT</sub>	Total Power V <sub>DD</sub> Supply Current	F <sub>REFERENCE CLOCK</sub> = 100MHz, C <sub>L</sub> = 5pf	86	130	mA
		F <sub>REFERENCE CLOCK</sub> = 200MHz, C <sub>L</sub> = 5pf	100	150	
		F <sub>REFERENCE CLOCK</sub> = 400MHz, C <sub>L</sub> = 5pf	122	190	

### NOTES:

1. Output banks 4 and 5 are toggling. Other output banks are powered down.
2. The termination resistors are excluded from these measurements.

## DC ELECTRICAL CHARACTERISTICS FOR LVPECL

Symbol	Parameter	Min.	Typ.	Max	Unit
V <sub>OH</sub>	Output Voltage HIGH, terminated through 50Ω tied to V <sub>DD</sub> - 2V	V <sub>DD</sub> - 1.2	—	V <sub>DD</sub> - 0.9	V
V <sub>OL</sub>	Output Voltage LOW, terminated through 50Ω tied to V <sub>DD</sub> - 2V	V <sub>DD</sub> - 1.95	—	V <sub>DD</sub> - 1.61	V
V <sub>SWING</sub>	Peak to Peak Output Voltage Swing	0.55	—	0.93	V

## POWER SUPPLY CHARACTERISTICS FOR LVPECL OUTPUTS<sup>(1)</sup>

Symbol	Parameter	Test Conditions <sup>(2)</sup>	Typ.	Max	Unit
I <sub>DDQ</sub>	Quiescent V <sub>DD</sub> Power Supply Current	REF = LOW Outputs enabled, All outputs unloaded	86	110	mA
I <sub>DDD</sub>	Dynamic V <sub>DD</sub> Power Supply Current per Output	V <sub>DD</sub> = Max., C <sub>L</sub> = 0pF	35	50	μA/MHz
I <sub>TOT</sub>	Total Power V <sub>DD</sub> Supply Current	F <sub>REFERENCE CLOCK</sub> = 100MHz, C <sub>L</sub> = 5pf	120	180	mA
		F <sub>REFERENCE CLOCK</sub> = 200MHz, C <sub>L</sub> = 5pf	130	190	
		F <sub>REFERENCE CLOCK</sub> = 400MHz, C <sub>L</sub> = 5pf	140	210	

### NOTES:

1. Output banks 4 and 5 are toggling. Other output banks are powered down.
2. The termination resistors are excluded from these measurements.

## AC TIMING ELECTRICAL CHARACTERISTICS

(SPREAD SPECTRUM GENERATION = OFF)

Symbol	Parameter	Test Conditions	Min.	Typ.	Max	Unit	
f <sub>IN</sub>	Input Frequency	Input Frequency Limit	1 <sup>(1)</sup>	—	400	MHz	
1/t1	Output Frequency	Single Ended Clock output limit (LVTTTL)	0.0049	—	200	MHz	
		Differential Clock output limit (LVPECL/LVDS)	0.0049	—	500		
f <sub>VCO</sub>	VCO Frequency	VCO operating Frequency Range	10	—	1100	MHz	
f <sub>PFD</sub>	PFD Frequency	PFD operating Frequency Range	0.4 <sup>(1)</sup>	—	400	MHz	
f <sub>BW</sub>	Loop Bandwidth	Based on loop filter resistor and capacitor values	0.03	—	40	MHz	
t2	Input Duty Cycle	Duty Cycle for Input	40	—	60	%	
t3	Output Duty Cycle	Measured at V <sub>DD</sub> /2, F <sub>OUT</sub> ≤ 200MHz	45	—	55	%	
		Measured at V <sub>DD</sub> /2, F <sub>OUT</sub> > 200MHz	40	—	60		
t4 <sup>(2)</sup>	Slew Rate SLEWx(bits) = 00	Single-Ended Output clock rise and fall time, 20% to 80% of V <sub>DD</sub> (Output Load = 15pf)	—	2.75	—	V/ns	
	Slew Rate SLEWx(bits) = 01	Single-Ended Output clock rise and fall time, 20% to 80% of V <sub>DD</sub> (Output Load = 15pf)	—	2	—		
	Slew Rate SLEWx(bits) = 10	Single-Ended Output clock rise and fall time, 20% to 80% of V <sub>DD</sub> (Output Load = 15pf)	—	1.25	—		
	Slew Rate SLEWx(bits) = 11	Single-Ended Output clock rise and fall time, 20% to 80% of V <sub>DD</sub> (Output Load = 15pf)	—	0.75	—		
t5	Rise Times	LVDS, 20% to 80%	—	850	—	ps	
	Fall Times		—	850	—		
	Rise Times	LVPECL, 20% to 80%	—	500	—		
	Fall Times		—	500	—		
t6	Output three-state Timing	Time for output to enter or leave three-state mode after SHUTDOWN/OE switches	—	—	150 + 1/F <sub>OUTX</sub>	ns	
t7	Clock Jitter <sup>(3,7)</sup>	Peak-to-peak period jitter, CLK outputs measured at V <sub>DD</sub> /2	f <sub>PFD</sub> > 20MHz	—	—	150	ps
			f <sub>PFD</sub> < 20MHz	—	200	—	
t8	Output Skew <sup>(8)</sup>	Skew between output to output on the same bank (bank 4 and bank 5 only) <sup>(4,5)</sup>	—	—	150	ps	
t9	Lock Time	PLL Lock Time from Power-up <sup>(6)</sup>	—	10	20	ms	
t10	Lock time <sup>(9)</sup>	PLL Lock time from shutdown mode	—	20	100	μs	

### NOTES:

1. Practical lower input frequency is determined by loop filter settings.
2. A slew rate of 2V/ns or greater should be selected for output frequencies of 100MHz and higher.
3. Input frequency is the same as the output with all output banks running at the same frequency.
4. Skew measured between all output pairs under identical input and output interfaces, same PLL and PLL multiplication and post divider value, transitions and load conditions on any one device.
5. Skew measured between the cross points of all differential output pairs under identical input and output interfaces, transitions and load conditions on any one device.
6. Includes loading the configuration bits from EEPROM to PLL registers. It does not include EEPROM programming/write time.
7. Guaranteed by design but not production tested.
8. Outputs are aligned upon device power-on. If an output divider ratio is changed (via programming or Manual Frequency Control), then outputs are no longer guaranteed to be synchronized.
9. Actual PLL lock time depends on the loop configuration.

## SPREAD SPECTRUM GENERATION SPECIFICATIONS

Symbol	Parameter	Description	Min.	Typ.	Max	Unit
f <sub>IN</sub>	Input Frequency	Input Frequency Limit	1 <sup>(1)</sup>	—	400	MHz
f <sub>MOD</sub>	Mod Freq	Modulation Frequency	—	33	—	kHz
f <sub>SPREAD</sub>	Spread Value	Amount of Spread Value (Programmable) - Down Spread	-0.5, -1, -2.5, -3.5, -4			%f <sub>OUT</sub>
		Amount of Spread Value (Programmable) - Center Spread	-0.5 to +0.5			

### NOTE:

1. Practical lower input frequency is determined by loop filter settings.

## TEST CIRCUITS AND CONDITIONS

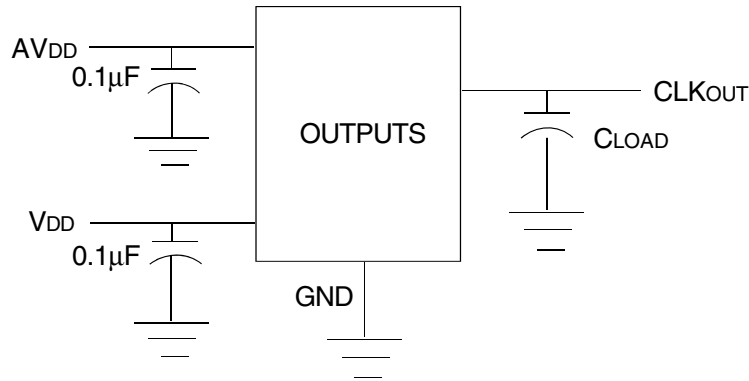

*Test Circuits for DC Outputs*

## OTHER TERMINATION SCHEME (BLOCK DIAGRAM)

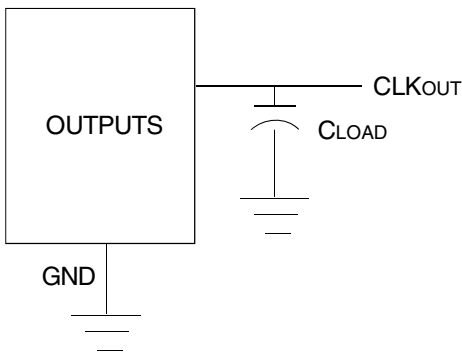

*LVTTL: -15pF for each output*

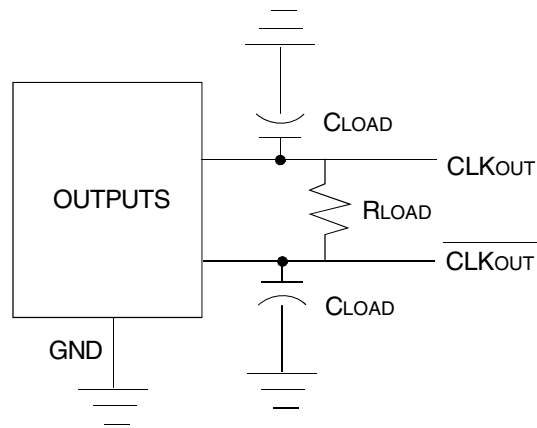

*LVDS: - 100Ω between differential outputs with 5pF*

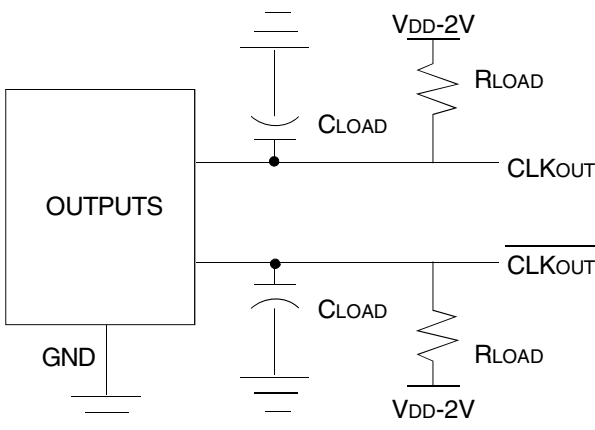

*LVPECL: - 50Ω to V<sub>DD</sub>-2V for each output with 5pF*

Cypress LVPECL:  
- 50Ω to V<sub>DD</sub>/2 for each output

RAM (PROGRAMMING REGISTER) TABLES

ADDR	BIT # (Default Settings)								Default Register Hex Value	BIT #								DESCRIPTION
	7	6	5	4	3	2	1	0		7	6	5	4	3	2	1	0	
0x00																		Read-Only
0x01																		
0x02																		
0x03																		
0x04	0	0	0	0	0	0	0	0	00								MFC	MFC=Manual Frequency Control Mode ('0'=All PLL Control (Default), '1'=PLL0 Control Only); GINEN0 to GINEN5=GINx Pins Enable Bits. ('1'=Enable (Default), '0'=No Connect (Internal State will be "Low")); Address 0x04, Bits[7:1] are reserved and should be set to '0'. Address 0x05, Bits 7, 6 are reserved and should be set to '1'.
0x05	1	1	1	1	1	1	1	1	FF			GINEN5	GINEN4	GINEN3	GINEN2	GINEN1	GINEN0	
0x06	0	0	1	1	0	0	0	0	30			XDRV[1:0]						XDRV=crystal drive strength ('00' = 1.4V, '01' = 2.3V, '10' = 3.2V pk-pk swing typical, '11'=XTAL_IN with external clock-default); When '11', XTALCAP[7:0] value must also be set to '0'. Bits 7,6, 3, 2, 1, 0 are reserved and should be set to '0'
0x07	0	0	0	0	0	0	0	0	00			XTALCAP[7:0]						XTAL load cap = 3.5pF+ (0.125 x XTALCAP[7:0]), 3.5pF to 35.4pF; Each XTAL pin to GND; (For example, '00000001'=0.125pF, '00000010'=0.25pF, '00000100'=0.5pF); Default = '00000000';
0x08	0	0	0	0	0	0	0	0	00	ODIV0_CONFIG0	IPQ[2:0]_CONFIG0			RZ0[3:0]_CONFIG0				
0x09	0	0	0	0	0	0	0	0	00	ODIV0_CONFIG1	IPQ[2:0]_CONFIG1			RZ0[3:0]_CONFIG1				
0x0A	0	0	0	0	0	0	0	0	00	ODIV0_CONFIG2	IPQ[2:0]_CONFIG2			RZ0[3:0]_CONFIG2				
0x0B	0	0	0	0	0	0	0	0	00	ODIV0_CONFIG3	IPQ[2:0]_CONFIG3			RZ0[3:0]_CONFIG3			PLL0 LOOP FILTER SETTING  Loop Filter Values for PLL0 - For 4 Configurations (Default value is '0'); CONFIG0 will be selected if GINx are disabled and operating in MFC mode	
0x0C	0	0	0	0	0	0	0	0	00	CP0[3:0]_CONFIG0		CZ0[3:0]_CONFIG0						
0x0D	0	0	0	0	0	0	0	0	00	CP0[3:0]_CONFIG1		CZ0[3:0]_CONFIG1						
0x0E	0	0	0	0	0	0	0	0	00	CP0[3:0]_CONFIG2		CZ0[3:0]_CONFIG2						
0x0F	0	0	0	0	0	0	0	0	00	CP0[3:0]_CONFIG3		CZ0[3:0]_CONFIG3						
0x10	0	0	0	0	0	0	0	0	00	DQ[7:0]_CONFIG0								
0x11	0	0	0	0	0	0	0	0	00	DQ[7:0]_CONFIG1								
0x12	0	0	0	0	0	0	0	0	00	DQ[7:0]_CONFIG2							PLL0 INPUT DIVIDER D0 SETTING  PLL0 D-Divider Values (Prescaler) - For 4 Configurations (Default value is '0');	
0x13	0	0	0	0	0	0	0	0	00	DQ[7:0]_CONFIG3								
0x14	0	0	0	0	0	0	0	0	00	NQ[7:0]_CONFIG0								
0x15	0	0	0	0	0	0	0	0	00	NQ[7:0]_CONFIG1								
0x16	0	0	0	0	0	0	0	0	00	NQ[7:0]_CONFIG2							PLL0 MULTIPLIER SETTING  CONFIG0 will be selected if GINx are disabled and operating in MFC mode.	
0x17	0	0	0	0	0	0	0	0	00	NQ[7:0]_CONFIG3								
0x18	0	0	0	0	0	0	0	0	00	A0[3:0]_CONFIG0			NQ[11:8]_CONFIG0					Total Multiplier Value $M0 = 2 * NQ[11:0] + A0 + 1 + SS\_OFFSET0 * 1/64$ When A0[3:0] = 0 and spread spectrum disabled, $M0 = 2 * NQ[11:0]$ ; When A0[3:0] > 0 and spread spectrum disabled, $M0 = 2 * NQ[11:0] + A0 + 1$ ;
0x19	0	0	0	0	0	0	0	0	00	A0[3:0]_CONFIG1			NQ[11:8]_CONFIG1					(Note: A < N-1, i.e. valid M values are 2, 4, 6, 8, 9, 10, 11, 12, 13, ..., 4095 assuming within IPFD and IVCO spec);
0x1A	0	0	0	0	0	0	0	0	00	A0[3:0]_CONFIG2			NQ[11:8]_CONFIG2					
0x1B	0	0	0	0	0	0	0	0	00	A0[3:0]_CONFIG3			NQ[11:8]_CONFIG3					
0x1C	0	0	0	0	0	0	0	0	00	SP	SH	OE6	OE5	OE4	OE3	OE2	OE1	SP=Shutdown/OE Polarity for SHUTDOWN/OE signal pin. ('0'= Active High (Default), '1'= Active Low); OE=Output Disable Function for OUTx. ('1'=OUTx disabled based on OE pin (Default for OUT2-6, Disable mode is defined by OEMx bits), '0'= Outputs enabled and no association with OE pin (Default));
0x1D	0	1	0	0	0	0	0	0	40		OKC	OS6	OS5	OS4	OS3	OS2	OS1	OS=Output Power Suspend function for OUTx. ('1'=OUTx will be suspended on GIN3/SUSPEND pin (MFC='1'), '0'= Always Enabled (Default)); PLLx=Determines which PLLx to suspend when GIN3 is programmed to be used as SUSPEND. It suspends all the outputs associated with that PLL. ('1' = suspends based on SUSPEND pin, '0'= PLL enabled and no association with SUSPEND pin (Default)); It over-rides OSx bits;
0x1E	0	0	0	0	0	0	0	0	00					PLLS2	PLLS1	PLLS0		SH=Determines the function of the SHUTDOWN/OE signal pin. ('1'=Global Shutdown; this over-rides OEx and OSx bits, '0'=Output Enable/Disable (Default));  OKC=lock OK count, '0'=8 cycles, '1'=1024 cycles (Default) of Input Clocks for Revertive Switchover Mode.  Address 0x1D, Bit 7: Address 0x1E, Bits [7:3] are reserved and should be set to '0'

RAM (PROGRAMMING REGISTER) TABLES

ADDR	BIT # (Default Settings)								Default Register Hex Value	BIT #								DESCRIPTION							
	7	6	5	4	3	2	1	0		7	6	5	4	3	2	1	0								
0x1F	0	0	0	0	0	0	0	0	00	OEM1[1:0]				SLEW1[1:0]				INV1	Configuring Output OUT1 INV1=Output Inversion for OUT1 ('0'=Non-Invert (Default), '1'=Invert); SLEW1=Slew Rate Settings for OUT1 output ('00'=2.75V/ns (Default), '01'=2V/ns, '10'=1.25V/ns, '11'=0.7V/ns); OEM1= Output Enable Mode for OUT1 output, when used with OE1 bit and SHUTDOWN/OE pin ('0x'= Tri-state (Default), '10'=Park Low, '11'=Park High); Address 0x1F, Bits 3, 1, 0 are reserved and should be set to '0'						
0x20	0	0	0	0	0	0	0	0	00	ODIV1_CONFIG0		IP1[2:0]_CONFIG0		RZ1[3:0]_CONFIG0				PLL1 LOOP FILTER SETTING  Loop Filter Values for PLL1 - For 4 Configurations (Default value is '0'); CONFIG0 will be selected if GINx are disabled and operating in MFC mode.  ODIV1_CONFIGx=Determines which one of the 2 'Qx-Divider' Configurations to use with, for any of the 'Qx-Divider' block associated with PLL1; Used in MFC mode; Default ODIV value is '0', and use CONFIG0 of Qx-Divider; Resistor = 0.3kΩ + RZ1[3:0] * 1kΩ, 0.3 to 15.3kΩ with 1kΩ Step, ('0000'=0.3kΩ, '0001'=1.3kΩ, '0010'=2.3kΩ, ...); Zero capacitor = 6pF + CZ1[3:0] * 27.2pF, 6pF to 414pF with 27.2pF Step, ('0000'=6pF, '0001'=33.2pF, '0010'=60.4pF, ...); Pole capacitor = 1.3pF + CP1[3:0] * 0.75pF, 1.3pF to 12.55pF with 0.75pF Step, ('0000'=1.3pF, '0001'=2.05pF, '0010'=2.8pF, ...) Charge pump current = 5 * 2^N1[2:0] μA, 5uA to 640uA with 5, 10, 20, 40, ... binary step;							
0x21	0	0	0	0	0	0	0	0	00	ODIV1_CONFIG1		IP1[2:0]_CONFIG1		RZ1[3:0]_CONFIG1											
0x22	0	0	0	0	0	0	0	0	00	ODIV1_CONFIG2		IP1[2:0]_CONFIG2		RZ1[3:0]_CONFIG2											
0x23	0	0	0	0	0	0	0	0	00	ODIV1_CONFIG3		IP1[2:0]_CONFIG3		RZ1[3:0]_CONFIG3											
0x24	0	0	0	0	0	0	0	0	00	CP1[3:0]_CONFIG0				CZ1[3:0]_CONFIG0											
0x25	0	0	0	0	0	0	0	0	00	CP1[3:0]_CONFIG1				CZ1[3:0]_CONFIG1											
0x26	0	0	0	0	0	0	0	0	00	CP1[3:0]_CONFIG2				CZ1[3:0]_CONFIG2											
0x27	0	0	0	0	0	0	0	0	00	CP1[3:0]_CONFIG3				CZ1[3:0]_CONFIG3											
0x28	0	0	0	0	0	0	0	0	00	D1[7:0]_CONFIG0								PLL1 INPUT DIVIDER D1 SETTING  PLL1 D-Divider Values (Prescaler) - For 4 Configurations (Default value is '0');							
0x29	0	0	0	0	0	0	0	0	00	D1[7:0]_CONFIG1															
0x2A	0	0	0	0	0	0	0	0	00	D1[7:0]_CONFIG2															
0x2B	0	0	0	0	0	0	0	0	00	D1[7:0]_CONFIG3															
0x2C	0	0	0	0	0	0	0	0	00	N1[7:0]_CONFIG0								PLL1 MULTIPLIER SETTING  CONFIG0 will be selected if GINx are disabled and operating in MFC mode.  N1[11:0]_CONFIGx - Part of PLL1 M Integer Feedback Divider Values (see equation below) - For 4 Configurations (Default value is '0'); A1[3:0]_CONFIGx - Part of PLL1 M Integer Feedback Divider Values (see equation below) - For 4 Configurations (Default value is '0'); SSC_OFFSET[5:0] - Spread Spectrum Fractional Multiplier Offset Value. See Spread Spectrum Settings in register address range 0x68-0x6F							
0x2D	0	0	0	0	0	0	0	0	00	N1[7:0]_CONFIG1															
0x2E	0	0	0	0	0	0	0	0	00	N1[7:0]_CONFIG2															
0x2F	0	0	0	0	0	0	0	0	00	N1[7:0]_CONFIG3															
0x30	0	0	0	0	0	0	0	0	00	A1[3:0]_CONFIG0				N1[11:8]_CONFIG0											
0x31	0	0	0	0	0	0	0	0	00	A1[3:0]_CONFIG1				N1[11:8]_CONFIG1											
0x32	0	0	0	0	0	0	0	0	00	A1[3:0]_CONFIG2				N1[11:8]_CONFIG2											
0x33	0	0	0	0	0	0	0	0	00	A1[3:0]_CONFIG3				N1[11:8]_CONFIG3											
0x34	0	1	0	0	0	1	1	0	46	SRC2[1:0]		SRC1[1:0]		SM[1:0]		PRIMCLK	PRIMCLK=Priority Selection for Input Clock ('0'=XTALIN/REF_IN becomes Primary (Default), '1'=CLK_IN becomes Primary); SM = Switchover Mode ('0x'=Manual, '10'=Auto-NonRevertive, '11'=Auto-Revertive (Default)); Bit 3 is reserved and should be set to '0'.								
0x35	0	1	0	1	0	1	0	1	55	SRC6[1:0]		SRC5[1:0]		SRC4[1:0]		SRC3[1:0]		SRCx[1:0]=Input Source Selection for Output Dividers 'Ox' blocks ('00'=Selected Input CLK, '01'=PLL0, '10'=PLL1, '11'=PLL2); Default on SRC1 is the selected input clock. Default on SRC2-6 is PLL0 which will be powered down.							
0x36	0	0	0	0	0	0	0	0	00	Read-Only															
0x37	0	0	0	0	0	0	0	0	00	Read-Only															
0x38	0	0	0	0	0	0	0	0	00	ODIV2_CONFIG0		IP2[2:0]_CONFIG0		RZ2[3:0]_CONFIG0				PLL2 LOOP FILTER SETTING  Loop Filter Values for PLL2 - For 4 Configurations (Default value is '0'); CONFIG0 will be selected if GINx are disabled and operating in MFC mode.  ODIV2_CONFIGx=Determines which one of the 2 'Qx-Divider' Configurations to use with, for any of the 'Qx-Divider' block associated with PLL2; Used in MFC mode; Default ODIV value is '0', and use CONFIG0 of Qx-Divider; Resistor = 0.3kΩ + RZ2[3:0] * 1kΩ, 0.3 to 15.3kΩ with 1kΩ Step, ('0000'=0.3kΩ, '0001'=1.3kΩ, '0010'=2.3kΩ, ...); Zero capacitor = 6pF + CZ2[3:0] * 27.2pF, 6pF to 414pF with 27.2pF Step, ('0000'=6pF, '0001'=33.2pF, '0010'=60.4pF, ...); Pole capacitor = 1.3pF + CP2[3:0] * 0.75pF, 1.3pF to 12.55pF with 0.75pF Step, ('0000'=1.3pF, '0001'=2.05pF, '0010'=2.8pF, ...) Charge pump current = 5 * 2^N2[2:0] μA, 5uA to 640uA with 5, 10, 20, 40, ... binary step;							
0x39	0	0	0	0	0	0	0	0	00	ODIV2_CONFIG1		IP2[2:0]_CONFIG1		RZ2[3:0]_CONFIG1											
0x3A	0	0	0	0	0	0	0	0	00	ODIV2_CONFIG2		IP2[2:0]_CONFIG2		RZ2[3:0]_CONFIG2											
0x3B	0	0	0	0	0	0	0	0	00	ODIV2_CONFIG3		IP2[2:0]_CONFIG3		RZ2[3:0]_CONFIG3											
0x3C	0	0	0	0	0	0	0	0	00	CP2[3:0]_CONFIG0				CZ2[3:0]_CONFIG0											
0x3D	0	0	0	0	0	0	0	0	00	CP2[3:0]_CONFIG1				CZ2[3:0]_CONFIG1											
0x3E	0	0	0	0	0	0	0	0	00	CP2[3:0]_CONFIG2				CZ2[3:0]_CONFIG2											
0x3F	0	0	0	0	0	0	0	0	00	CP2[3:0]_CONFIG3				CZ2[3:0]_CONFIG3											

RAM (PROGRAMMING REGISTER) TABLES

ADDR	BIT # (Default Settings)							Default Register Hex Value	BIT #							DESCRIPTION
	7	6	5	4	3	2	1		7	6	5	4	3	2	1	
0x40	0	0	0	0	0	0	0	00	D2[7:0]_CONFIG0							PLL2 INPUT DIVIDER D2 SETTING PLL2 D-Divider Values (Prescaler) - For 4 Configurations (Default value is '0');
0x41	0	0	0	0	0	0	0	00	D2[7:0]_CONFIG1							
0x42	0	0	0	0	0	0	0	00	D2[7:0]_CONFIG2							
0x43	0	0	0	0	0	0	0	00	D2[7:0]_CONFIG3							
0x44	0	0	0	0	0	0	0	00	N2[7:0]_CONFIG0							PLL2 MULTIPLIER SETTING CONFIG0 will be selected if GINx are disabled and operating in MFC mode. N2[11:0]_CONFIGx - Part of PLL2 M Integer Feedback Divider Values (see equation below) - For 4 Configurations (Default value is '0'); Total Multiplier Value M2 = N2; Bits [7:4] in addresses 0x48, 0x49, 0x4A, and 0x4B are reserved and should be set to '0'
0x45	0	0	0	0	0	0	0	00	N2[7:0]_CONFIG1							
0x46	0	0	0	0	0	0	0	00	N2[7:0]_CONFIG2							
0x47	0	0	0	0	0	0	0	00	N2[7:0]_CONFIG3							
0x48	0	0	0	0	0	0	0	00				N2[11:8]_CONFIG0				Bits [7:4] in addresses 0x48, 0x49, 0x4A, and 0x4B are reserved and should be set to '0'
0x49	0	0	0	0	0	0	0	00				N2[11:8]_CONFIG1				
0x4A	0	0	0	0	0	0	0	00				N2[11:8]_CONFIG2				
0x4B	0	0	0	0	0	0	0	00				N2[11:8]_CONFIG3				
0x4C	0	0	0	0	0	0	0	00	OEM2[1:0]	SLEW2[1:0]		INV2				Configuring Output OUT2 INV2=Output Inversion for OUT2 ('0'= Non-Invert (Default), '1'=Invert); SLEW2=Slew Rate Settings for OUT2 output ('00'= 2.75V/ns (Default), '01'=2V/ns, '10'=1.25V/ns, '11'=0.7V/ns); OEM2= Output Enable Mode for OUT2 output, when used with OE2 bit and SHUTDOWN/OE pin ('0x' = Tri-state (Default), '10'=Park Low, '11'=Park High); Q2[xcx]=Output Divider 'Q2' Values (Default value is '2') - Support 2 output configurations when used in MFC mode; PM2[xcx]=Divide Mode, ('00'=Divider Disabled; '01'=Divide by 1; '10'=Divide by 2; '11'=Divide by (Q+2) (Default)); (Note: To enable OUT2, PM2 register bit values for both CONFIG0 and CONFIG1 configurations must be non-zero.)
0x4D	1	0	1	1	1	0	1	BB	Q2[1:0]_CONFIG1	PM2[1:0]_CONFIG1		Q2[1:0]_CONFIG0		PM2[1:0]_CONFIG0		
0x4E	0	0	0	0	0	0	0	00	Q2[9:2]_CONFIG0							Address 0x4C, Bits 3, 1, 0 are reserved and should be set to '0'
0x4F	0	0	0	0	0	0	0	00	Q2[9:2]_CONFIG1							
0x50	0	0	0	0	0	0	0	00	OEM3[1:0]	SLEW3[1:0]		INV3				Configuring Output OUT3 INV3=Output Inversion for OUT3 ('0'= Non-Invert (Default), '1'=Invert); SLEW3=Slew Rate Settings for OUT3 output ('00'= 2.75V/ns (Default), '01'=2V/ns, '10'=1.25V/ns, '11'=0.7V/ns); OEM3= Output Enable Mode for OUT3 output, when used with OE3 bit and SHUTDOWN/OE pin ('0x' = Tri-state (Default), '10'=Park Low, '11'=Park High); Q3[xcx]=Output Divider 'Q3' Values (Default value is '2') - Support 2 output configurations when used in MFC mode; PM3[xcx]=Divide Mode, ('00'=Divider Disabled; '01'=Divide by 1; '10'=Divide by 2; '11'=Divide by (Q+2) (Default)); (Note: To enable OUT3, PM3 register bit values for both CONFIG0 and CONFIG1 configurations must be non-zero.)
0x51	1	0	1	1	1	0	1	BB	Q3[1:0]_CONFIG1	PM3[1:0]_CONFIG1		Q3[1:0]_CONFIG0		PM3[1:0]_CONFIG0		
0x52	0	0	0	0	0	0	0	00	Q3[9:2]_CONFIG0							Address 0x50, Bits 3, 1, 0 are reserved and should be set to '0'
0x53	0	0	0	0	0	0	0	00	Q3[9:2]_CONFIG1							
0x54	0	0	0	0	1	1	0	0C	OEM4[1:0]	SLEW4[1:0]		INV4_1 INV4_0		LVL4[1:0]		Configuring Output OUT4 INV4_0=Output Inversion for OUT4 ('0'= Invert, '1'=Non-Invert (Default)); INV4_1=Output Inversion for OUT4 ('0'= Invert, '1'=Non-Invert (Default)); SLEW4=Slew Rate Settings for OUT4 output ('00'= 2.75V/ns (Default), '01'=2V/ns, '10'=1.25V/ns, '11'=0.7V/ns); OEM4= Output Enable Mode for OUT4 output, when used with OE4 bit and SHUTDOWN/OE pin ('0x' = Tri-state (Default), '10'=Park Low, '11'=Park High); LVL4=Output IO Standard Selection, ('00'=LVTTTL (Default), '01'=LVDS, '10'=LVPECL, '11'=Reserved); Q4[xcx]=Output Divider 'Q4' Values (Default value is '2') - Support 2 output configurations when used in MFC mode; PM4[xcx]=Divide Mode, ('00'=Divider Disabled; '01'=Divide by 1; '10'=Divide by 2; '11'=Divide by (Q+2) (Default)); (Note: To enable OUT4, PM4 register bit values for both CONFIG0 and CONFIG1 configurations must be non-zero.)
0x55	1	0	1	1	1	0	1	BB	Q4[1:0]_CONFIG1	PM4[1:0]_CONFIG1		Q4[1:0]_CONFIG0		PM4[1:0]_CONFIG0		
0x56	0	0	0	0	0	0	0	00	Q4[9:2]_CONFIG0							When using LVPECL or LVDS outputs, SLEW4 must be set to '00'.
0x57	0	0	0	0	0	0	0	00	Q4[9:2]_CONFIG1							
0x58	0	0	0	0	1	1	0	0C	OEM5[1:0]	SLEW5[1:0]		INV5_1 INV5_0		LVL5[1:0]		Configuring Output OUT5 INV5_0=Output Inversion for OUT5 ('0'= Invert, '1'=Non-Invert (Default)); INV5_1=Output Inversion for OUT5 ('0'= Invert, '1'=Non-Invert (Default)); SLEW5=Slew Rate Settings for OUT5 output ('00'= 2.75V/ns (Default), '01'=2V/ns, '10'=1.25V/ns, '11'=0.7V/ns); OEM5= Output Enable Mode for OUT5 output, when used with OE5 bit and SHUTDOWN/OE pin ('0x' = Tri-state (Default), '10'=Park Low, '11'=Park High); LVL5=Output IO Standard Selection, ('00'=LVTTTL (Default), '01'=LVDS, '10'=LVPECL, '11'=Reserved); Q5[xcx]=Output Divider 'Q5' Values (Default value is '2') - Support 2 output configurations when used in MFC mode; PM5[xcx]=Divide Mode, ('00'=Divider Disabled; '01'=Divide by 1; '10'=Divide by 2; '11'=Divide by (Q+2) (Default)); (Note: To enable OUT5, PM5 register bit values for both CONFIG0 and CONFIG1 configurations must be non-zero.)
0x59	1	0	1	1	1	0	1	BB	Q5[1:0]_CONFIG1	PM5[1:0]_CONFIG1		Q5[1:0]_CONFIG0		PM5[1:0]_CONFIG0		
0x5A	0	0	0	0	0	0	0	00	Q5[9:2]_CONFIG0							When using LVPECL or LVDS outputs, SLEW5 must be set to '00'.
0x5B	0	0	0	0	0	0	0	00	Q5[9:2]_CONFIG1							
0x5C	0	0	0	0	0	1	1	03	OEM6[1:0]	SLEW6[1:0]		INV6				Configuring Output OUT6 INV6=Output Inversion for OUT6 ('0'= Non-Invert (Default), '1'=Invert); SLEW6=Slew Rate Settings for OUT6 output ('00'= 2.75V/ns (Default), '01'=2V/ns, '10'=1.25V/ns, '11'=0.7V/ns); OEM6= Output Enable Mode for OUT6 output, when used with OE6 bit and SHUTDOWN/OE pin ('0x' = Tri-state (Default), '10'=Park Low, '11'=Park High); Q6[xcx]=Output Divider 'Q6' Values (Default value is '2') - Support 2 output configurations when used in MFC mode; PM6[xcx]=Divide Mode, ('00'=Divider Disabled; '01'=Divide by 1; '10'=Divide by 2; '11'=Divide by (Q+2) (Default)); (Note: To enable OUT6, PM6 register bit values for both CONFIG0 and CONFIG1 configurations must be non-zero.)
0x5D	1	0	1	1	1	0	1	BB	Q6[1:0]_CONFIG1	PM6[1:0]_CONFIG1		Q6[1:0]_CONFIG0		PM6[1:0]_CONFIG0		
0x5E	0	0	0	0	0	0	0	00	Q6[9:2]_CONFIG0							Address 0x5C, Bits 3 is reserved and should be set to '0' Address 0x5E, Bits 1, 0 are reserved and should be set to '11'
0x5F	0	0	0	0	0	0	0	00	Q6[9:2]_CONFIG1							

RAM (PROGRAMMING REGISTER) TABLES

ADDR	BIT # (Default Settings)								Default Register Hex Value	BIT #								DESCRIPTION																				
	7	6	5	4	3	2	1	0		7	6	5	4	3	2	1	0																					
0x60	0	0	0	0	0	0	0	0	00	TSSC0[3:0]				NSSC0[3:0]				<b>SPREAD SPECTRUM SETTINGS FOR PLL0</b> SS_OFFSET0=SS Fractional Offset/ First Sample (Unsigned); TSSC0=# of PFD Cycles Per SS Cycle Step, TSSC=10000 for SSC off (Default); NSSC0=# of SS Samples to Use from SS Memory (Default is '0'); DITH0=LSB DITHER on Σ, ('1'=dither on, '0'=off (Default)); X2_0=Σ output x2, ('1'=x2, '0'=normal (Default)); SD0=Delta-encoded samples (unsigned); Waveform start with SS_OFFSET0, then SS_OFFSET0+SD0[0], etc. (Default is '0');																				
0x61	0	0	0	0	0	0	0	0	00	DITH0	X2_0	SS_OFFSET0[5:0]																										
0x62	0	0	0	0	0	0	0	0	00	SD0[3:0][1]				SD0[3:0][0]																								
0x63	0	0	0	0	0	0	0	0	00	SD0[3:0][3]				SD0[3:0][2]																								
0x64	0	0	0	0	0	0	0	0	00	SD0[3:0][5]				SD0[3:0][4]																								
0x65	0	0	0	0	0	0	0	0	00	SD0[3:0][7]				SD0[3:0][6]																								
0x66	0	0	0	0	0	0	0	0	00	SD0[3:0][9]				SD0[3:0][8]																								
0x67	0	0	0	0	0	0	0	0	00	SD0[3:0][11]				SD0[3:0][10]																								
0x68	0	0	0	0	0	0	0	0	00	TSSC1[3:0]				NSSC1[3:0]				<b>SPREAD SPECTRUM SETTINGS FOR PLL1</b> SS_OFFSET1=SS Fractional Offset/ First Sample (Unsigned); TSSC1=# of PFD Cycles Per SS Cycle Step, TSSC=10000 for SSC off (Default); NSSC1=# of SS Samples to Use from SS Memory (Default is '0'); DITH1=LSB DITHER on Σ, ('1'=dither on, '0'=off (Default)); X2_1=Σ output x2, ('1'=x2, '0'=off (Default)); SD1=Delta-encoded samples (unsigned); Waveform start with SS_OFFSET1, then SS_OFFSET1+SD1[0], etc. (Default is '0');																				
0x69	0	0	0	0	0	0	0	0	00	DITH1	X2_1	SS_OFFSET1[5:0]																										
0x6A	0	0	0	0	0	0	0	0	00	SD1[3:0][1]				SD1[3:0][0]																								
0x6B	0	0	0	0	0	0	0	0	00	SD1[3:0][3]				SD1[3:0][2]																								
0x6C	0	0	0	0	0	0	0	0	00	SD1[3:0][5]				SD1[3:0][4]																								
0x6D	0	0	0	0	0	0	0	0	00	SD1[3:0][7]				SD1[3:0][6]																								
0x6E	0	0	0	0	0	0	0	0	00	SD1[3:0][9]				SD1[3:0][8]																								
0x6F	0	0	0	0	0	0	0	0	00	SD1[3:0][11]				SD1[3:0][10]																								
0x70																			Read-Only																			
0x71																																						
0x72																																						
0x73																																						
0x74																																						
0x75																																						
0x76																																						
0x77																																						
0x78																																						
0x79																																						
0x7A																																						
0x7B																			CRC error in EEPROM CERR = CRC error bit indicator ('1' = CRC error)																			
0x7C																																						Read-Only
0x7D																																						
0x7E																																						
0x7F																																						
0x80																																						
0x81																																						
0x82																																						
0x83																																						
0x84																																						
0x85																																						
0x86																																						
0x87																																						
0x88																																						

## RECOMMENDED LANDING PATTERN

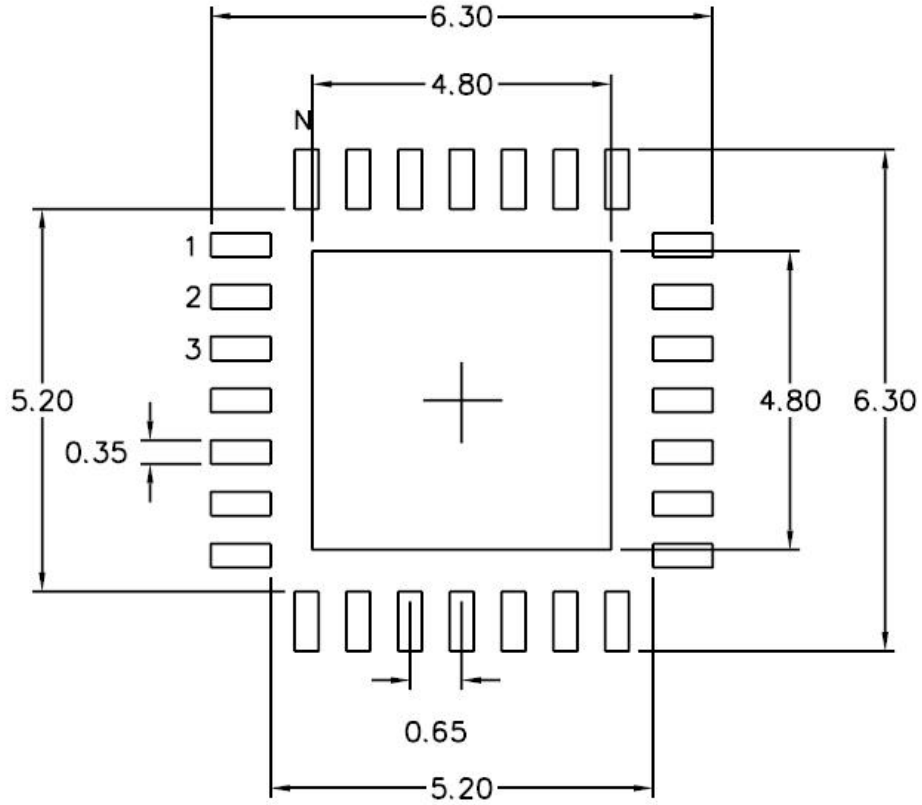

*NL 28 pin*

NOTE: All dimensions are in millimeters.

## ORDERING INFORMATION

IDT XXXXX XX X  
Device Type Package Process

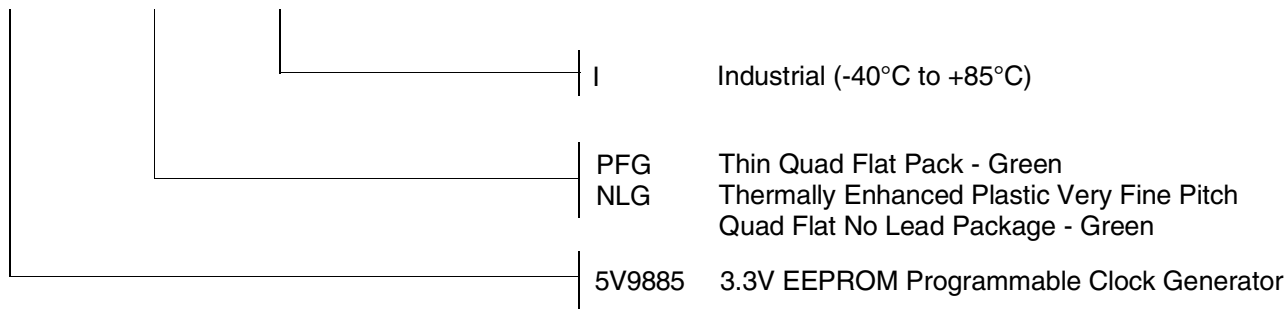

**CORPORATE HEADQUARTERS**  
6024 Silver Creek Valley Road  
San Jose, CA 95138

**for SALES:**  
800-345-7015 or 408-284-8200  
fax: 408-284-2775  
www.idt.com

**for Tech Support:**  
clockhelp@idt.com