

Application Manual

Real Time Clock Module

RTC-8564 JE/NB

Model	Product Number
RTC-8564JE	Q4185647x000100
RTC-8564NB	Q4185649x000200



SEIKO EPSON CORPORATION



*In pursuit of "Saving" Technology ,Epson electronic device.
Our Lineup of semiconductors, Liquid crystal displays and quartz devices
assists in creating the products of our customers' dreams.
Epson IS energy savings.*

NOTICE

- *The material is subject to change without notice.*
- *Any part of this material may not be reproduced or duplicated in any form or any means without the written permission of Seiko Epson.*
- *The information, applied circuit, program, using way etc., written in this material is just for reference. Seiko Epson does not assume any liability for the occurrence of infringing any patent or copyright of third party. This material does not authorize the licence for any patent or intellectual property rights.*
- *Any product described in this material may contain technology or the subject relating to strategic products under the control of the Foreign Exchange and Foreign Trade Law of Japan and may require an export licence from the Ministry of International Trade and industry or other approval from another government agency.*
- *The products (except for some product for automotive applications) listed up on this material are designed to be used with ordinary electronic equipment (OA equipment, AV equipment, communications equipment, measuring instruments etc). Seiko Epson does not assume any liability for the case using the products with the appoication required high reliability or safety extremely (such as aerospace equipment etc). When intending to use any our product with automotive application and the other application than ordinary electronic equipments as above, please contact our sales representatives in advance.*

CONTENTS

1. Overview	1
2. Block diagram	1
3. Terminal description	2
3.1. Terminal connections	2
3.2. Terminal functions	2
4. Absolute maximum ratings	3
5. Recommended operating conditions	3
6. Frequency characteristics	3
7. Electrical characteristics	3
7.1. DC electrical characteristics	3
7.2. AC electrical characteristics	4
8. How to use	5
8.1. Register table	5
8.2. Register description	5
8.2.1. Control register 1	5
8.2.2. Control register 2	6
8.2.3. Clock and calendar registers, and VL bit and century bit	6
8.2.4. Alarm registers	7
8.2.5. CLKOUT frequency selection and timer registers	7
8.3. Access procedure	8
8.3.1. Characteristic of the I ² C-BUS	8
8.3.2. Bit transfer	8
8.3.3. Start condition and stop condition	8
8.3.4. Slave address	8
8.3.5. System structure	9
8.3.6. Acknowledge	9
8.3.7. I ² C-BUS protocol	10
8.4. Typical connection to micro computers	11
9. External dimensions / Marking layout	12
9.1. External dimensions	12
9.2. Marking layout	12
10. Reference data	13
11. Application notes	14
11.1. Notes on handling	14
11.2. Notes on packaging	14

I²C-Bus Interface Real Time Clock Module

RTC - 8564 JE/NB

- Built-in crystal oscillator running at 32.768 kHz
- Compliant with I²C high-speed bus specifications (400 kHz)
- Equipped with alarm, timer, and frequency output (32.768 kHz, 1024 Hz, 32 Hz, 1 Hz) features
- Inclusion of century bit to enable correct date even after year 2000
- Wide range of interface voltage between 1.8 V and 5.5 V
- Wide range of clock voltage between 1.0 V and 5.5 V (Ta = -20 °C to +70 °C)
- Low power consumption at 275 nA / 3.0 V (Typ.)
- Real-time clock function
 Clock/calendar function, auto leap year correction function, etc.

The I²C-BUS is a trademark of PHILIPS ELECTRONICS N.V.

1. Overview

This module is a serial interface real time clock that has a built-in crystal oscillator. The module offers many functions such as calendar clock, alarm, and timer. All of them can be controlled with a two (2) lines interface. Also, the regular frequency output can be selected from programs. Because this module has multiple features packaged in the same surface, it is ideally suited for applications such as mobile phones, handy terminals or other small electronic systems.

2. Block diagram

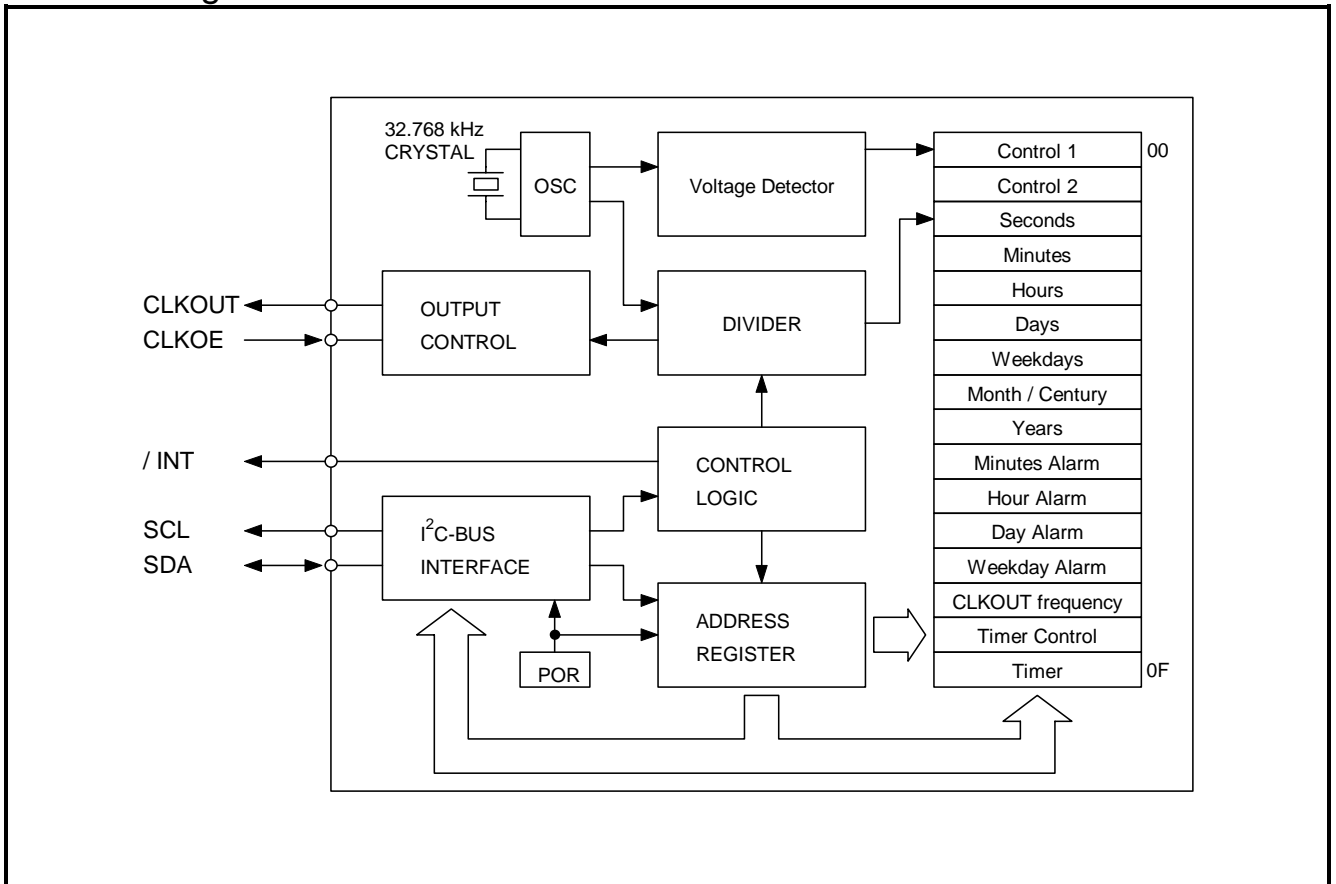

3. Terminal description

3.1. Terminal connections

RTC - 8564 JE		RTC - 8564 NB	
1. N.C.	<p>VSOJ - 20 pin</p>	20. N.C.	<p>SON - 22 pin</p>
2. N.C.		19. N.C.	
3. CLKOE		18. N.C.	
4. VDD		17. N.C.	
5. CLKOUT		16. N.C.	
6. SCL		15. N.C.	
7. SDA		14. N.C.	
8. (GND)		13. N.C.	
9. GND		12. N.C.	
10. / INT		11. N.C.	
1. / INT		22. N.C.	
2. GND		21. N.C.	
3. (GND)		20. N.C.	
4. N.C.		19. N.C.	
5. SDA		18. N.C.	
6. SCL		17. N.C.	
7. CLKOUT		16. N.C.	
8. VDD		15. N.C.	
9. CLKOE		14. N.C.	
10. N.C.		(13) -	
11. N.C.		(12) -	

3.2. Terminal functions

Signal name	I/O	Signal description
SCL	Input	For input of the serial clock.
SDA	Bi-Directional	This pin synchronizes with a serial clock and input/output address, data, acknowledge bit, etc. The pin is an open-drain in output mode. Be sure to use the appropriate pull-up resistors according to the capacitance of the signal lines.
CLKOUT	Output	This pin outputs frequency (32.768 kHz, 1024 Hz, 32 Hz, 1 Hz) selected by the program. The pin is an C-MOS terminal. When initial power is supplied (power supply starting from 0 V), the power-on reset function causes 32.768 kHz to be output. When output stops, the CLKOUT pin goes to LOW. Control of CLKOE pin is necessary to control this function justly.
CLKOE	Input	This pin control the frequency output from CLKOUT pin. When this pin is LOW ,frequency output is inhibited by all means. When this pin is HIGH and FE-Bit is "1", frequency output is available.
/ INT	Output	This pin outputs an interrupt signal such as alarm and timer. The pin is an open-drain terminal.
VDD	-	This pin connects to the + power source.
GND	-	This pin connects to the ground.
(GND)	-	This pin has the same voltage level as GND. Do not connect externally.
N.C.	-	This pin is not connected internally. But , In RTC-8564NB(SON-22pin), all pins from 14 pin to 22 pin are connected with inside frame mutually. Use OPEN, or GND or VDD to connect.

* Be sure to connect a filter capacity of at least 0.1 μF closely between VDD and GND.

4. Absolute maximum ratings

GND=0 V

Parameter	Symbol	Condition	Min.	Max.	Unit
Supply Voltage	VDD	Between VDD and GND	-0.5	+6.5	V
Supply Voltage	IdD	VDD pin	-50	50	mA
Input Voltage	Vi	Input pin	GND-0.5	VDD +0.5	V
Output Voltage	Vo	/ INT pin	GND-0.5	VDD +0.5	V
DC Input Current	Ii		-10	10	mA
DC Output Current	Io		-10	10	mA
Storage Temperature Range	TSTG	Stored bare product after unpacking	-55	+125	°C

5. Recommended operating conditions

GND=0 V

Parameter	Symbol	Condition	Min.	Max.	Unit
Supply voltage range	VDD	I ² C-BUS access at 400 kHz	1.8	5.5	V
Clock voltage range	VDD		VLOW	5.5	V
Operating temperature range	TOPR	No condensation	-40	+85	°C

6. Frequency characteristics

GND=0 V

Parameter	Symbol	Condition	Max.	Unit
Frequency precision	$\Delta f / f$	Ta = +25 °C VDD = 3.0 V	5 ± 23 (*1)	× 10 ⁻⁶
Frequency voltage characteristics	f / V	Ta = +25 °C VDD = 1.0 V to 5.5 V	± 2 Max.	× 10 ⁻⁶ / V
Frequency temperature characteristics	Top	Ta = -10 to +70 °C VDD = 3.0 V Reference at +25 °C	+10 / -120	× 10 ⁻⁶
Oscillation startup-up time	tSTA	Ta = +25 °C VDD = 1.8 V	3 Max.	s
Aging	fa	Ta = +25 °C VDD = 3.0 V ; first year	± 5 Max.	× 10 ⁻⁶ / year

*1) Equivalent to 1 minute of monthly deviation. (excluding offset)

7. Electrical characteristics

7.1. DC electrical characteristics

* If not specifically indicated, GND=0 V, VDD=1.8 V to 5.5 V, Ta= -40 °C to +85 °C

Parameter	Symbol	Pin	Condition	Min.	Typ.	Max.	Unit
Power current (during access)	IDD0		fSCL=400 kHz fSCL=100 kHz			800 200	μA μA
Power current (not during access)	IDD		fSCL=0 Hz, VDD=5.0 V fSCL=0 Hz, VDD=3.0 V fSCL=0 Hz, VDD=2.0 V		330 275 250	800 700 650	nA nA nA
Power current (not during access) (CLKOUT=32.768 kHz, LOAD is 0 pF)	IDD32K		fSCL=0 Hz, VDD=5.0 V fSCL=0 Hz, VDD=3.0 V fSCL=0 Hz, VDD=2.0 V		2.5 1.5 1.1	3.4 2.2 1.6	μA μA μA
"L" input voltage	VIL			GND - 0.5		0.3 × VDD	V
"H" input voltage	VIH			0.7 × VDD		VDD + 0.5	V
"L" output voltage	IOL (SDA)	SDA	VOL=0.4 V, VDD=5 V	-3			mA
"L" output current	IOL (/INT)	/ INT	VOL=0.4 V, VDD=5 V	-1			mA
"L" output current	IOL (CLKOUT)	CLKOUT	VOL=0.4 V, VDD=5 V	-1			mA
"H" output current	IOH (CLKOUT)	CLKOUT	VOH=4.6 V, VDD=5 V			1	mA
Leakage current	ILO		VO=VDD or GND	-1		1	μA
Low voltage detection	VLOW		Ta= -40 °C to +85 °C Ta= -20 °C to +70 °C		0.9 0.9	1.1 1.0	V

7.2. AC electrical characteristics

* If not specifically indicated, GND=0 V, VDD=1.8 V to 5.5 V, Ta= -40 °C to +85 °C

Parameter	Symbol	Condition	Min.	Typ.	Max.	Unit
SCL clock frequency	fSCL				400	kHz
Start condition set-up time	tSU; STA		0.6			μs
Start condition hold time	tHD; STA		0.6			μs
Data set-up time	tSU; DAT		100			ns
Data hold time	tHD; DAT		0			ns
Stop condition set-up time	tSU; STO		0.6			μs
Bus free time between a STOP and START condition	tBUF		1.3			μs
SCL "L" time	tLOW		1.3			μs
SCL "H" time	tHIGH		0.6			μs
SCL and SDA rise time	tr				0.3	μs
SCL and SDA fall time	tf				0.3	μs
Tolerance spike time on bus	tSP				50	ns

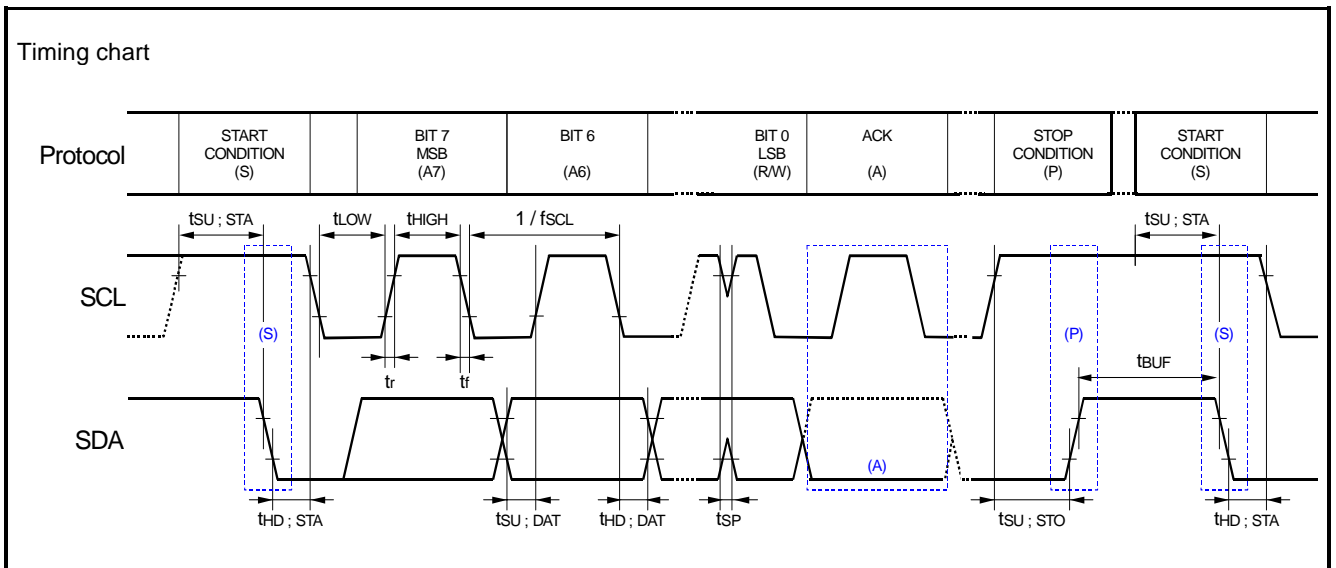

Note : I²C access time between a START and a START condition or between a START and a STOP condition to this device must be less than one second.

8. How to use

8.1. Register table

Address	Function	bit 7	bit 6	bit 5	bit 4	bit 3	bit 2	bit 1	bit 0
00	Control 1	TEST	0	STOP	0	TEST	0	0	0
01	Control 2	0	×	0	TI / TP	AF	TF	AIE	TIE
02	Seconds	VL	40	20	10	8	4	2	1
03	Minutes	×	40	20	10	8	4	2	1
04	Hours	×	×	20	10	8	4	2	1
05	Days	×	×	20	10	8	4	2	1
06	Weekdays	×	×	×	×	×	4	2	1
07	Months / Century	C	×	×	10	8	4	2	1
08	Years	80	40	20	10	8	4	2	1
09	Minute Alarm	AE	40	20	10	8	4	2	1
0A	Hour Alarm	AE	×	20	10	8	4	2	1
0B	Day Alarm	AE	×	20	10	8	4	2	1
0C	Weekday Alarm	AE	×	×	×	×	4	2	1
0D	CLKOUT frequency	FE	×	×	×	×	×	FD1	FD0
0E	Timer control	TE	×	×	×	×	×	TD1	TD0
0F	Timer	128	64	32	16	8	4	2	1

Notes ;

- (1) When the power is turned on initially, the FD1 and FD0 bits are cleared to 0. Also, FE and VL bits are set to 1, but because other the register values of other bits are unknown, always make their initial settings. When doing so, do not make settings for date and time that are impossible. We do not guarantee proper operation of the clock for such settings.
- (2) While there is a bit at address 00 for setting the test mode, the test mode is a special operation mode that is used by EPSON for testing devices. Be sure not to set it to 1. If it is set to the test mode, all operations of the device will not be guaranteed. Therefore, be careful when access to address 00.
- (3) Be sure to set bit '0' of address 00,01 (Control1,2) to zero.
- (4) All count data at address 02 through 05 and 08 through 0B is in the BCD format.
- (5) Write to bit '×' is not possible, and its read-out value is not fixed. Be sure to mask it after bit '×' is read out.

8.2. Register description

8.2.1. Control register 1

Address	Function	bit 7	bit 6	bit 5	bit 4	bit 3	bit 2	bit 1	bit 0
00	Control 1	TEST	0	STOP	0	TEST	0	0	0

- TEST

The two TEST bits are for testing devices. Therefore be sure to set them to zeros. If they are accidentally set to 1, they may immediately modify the clock data or result in abnormal time.

- STOP

When this bit becomes zero, the device's time function operates. When it is set to 1, all internal count down chain are goes into the zero clear state. If it is cleared together with the time reporting, the time can be adjusted accurately up to one second. As for output of CLKOUT, STOP doesn't affect frequency output of 32768 Hz. But output stops at the time of frequency setting except 32768 Hz by STOP =1.

8.2.2. Control register 2

Address	Function	bit 7	bit 6	bit 5	bit 4	bit 3	bit 2	bit 1	bit 0
01	Control 2	0	×	0	TI / TP	AF	TF	AIE	TIE

- TI/TP (Interrupt Signal Output Mode Select. Interrupt / Periodic)
If this bit is set to 0, when the timer counts down in the single operation mode and becomes zero, it sets the TF flag and then stops. If this bit is set to 1, when the timer in the repeat mode becomes zero, it sets the TF flag, and it furthermore reload the initial value and repeat to count down. As long as the TF flag is not cleared, the set is maintained.
- AF (Alarm Flag)
This is a flag bit which goes into the set state when an alarm occurs.
- TF (Timer Flag)
This is a flag bit which goes into the set state when the timer counts down within the specified cycle and becomes zero.
- AIE (Alarm Interrupt Enable)
This bit determines whether to output the alarm flag state to the /INT pin. When it is set to 1, AF=1 then /INT becomes LOW. When it is set to 0, the information is not output to the /INT pin.
- TIE (Timer Interrupt Enable)
This bit determines whether to output the Timer flag state to the /INT pin. When it is set to 1, TF=1 then /INT becomes LOW. When it is set to 0, the information is not output to the /INT pin.

(Note)

The /INT pin outputs the logical sum of the respective signal of alarm interrupt and timer interrupt. When an interrupt occurs, the AF/TF flag is read out. Therefore, be sure to check to see which interrupt event has occurred. When alarm and timer are both prohibited. The /INT pin will not become LOW active. If all hardware interrupts cannot be used due to system constraints, after the above setup, be sure to use the software to monitor the interrupt flags for AF and TF.

8.2.3. Clock and calendar registers, and VL bit and century bit

Address	Function	bit 7	bit 6	bit 5	bit 4	bit 3	bit 2	bit 1	bit 0
02	Seconds	VL	40	20	10	8	4	2	1
03	Minutes	×	40	20	10	8	4	2	1
04	Hours	×	×	20	10	8	4	2	1
05	Days	×	×	20	10	8	4	2	1
06	Weekdays	×	×	×	×	×	4	2	1
07	Months / Century	C	×	×	10	8	4	2	1
08	Years	80	40	20	10	8	4	2	1

If data and time are set to impossible values, the clock cannot operate correctly. Therefore pay attention when handling them.

- VL (Voltage Low bit)
This is the bit for detecting low voltage. When the power source's voltage drops below VLOW[V]*, this flag is set to 1.
After the initial power-on, it is set to 1. If this flag is set to 1 after recovery from the backup state, this means during the backup the power was low, and all data need to be initialized.
But this bit is intended to detect the situation when VDD is decreasing slowly for example under battery operation.
In other words, chattering doesn't detect it.
However, because this bit is write cleared regardless of the data, before performing a write to this register, be sure to read out its value.

*See the description on DC electrical characteristics.

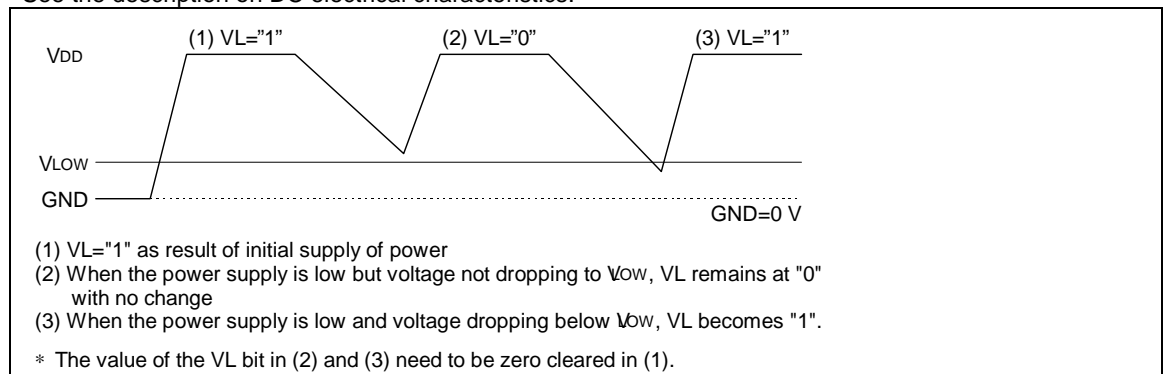

• C (Century bit)

This bit indicates change of century. When the year digit data overflows from 99 to 00, this bit is set. By presetting it to 0 while still in the 20th century, it will be set in year 2000, but in fact the first year in the 21 century should be 2001.

• Weekdays registers (Example for allotment of a day.)

Address	Function	bit 6	bit 5	bit 4	bit 3	bit 2	bit 1	bit 0	Week
06	Weekdays	x	x	x	x	0	0	0	SUN
		x	x	x	x	0	0	1	MON
		x	x	x	x	0	1	0	TUE
		x	x	x	x	0	1	1	WED
		x	x	x	x	1	0	0	THU
		x	x	x	x	1	0	1	FRI
		x	x	x	x	1	1	0	SAT

8.2.4. Alarm registers

Address	Function	bit 7	bit 6	bit 5	bit 4	bit 3	bit 2	bit 1	bit 0
09	Minute Alarm	AE	40	20	10	8	4	2	1
0A	Hour Alarm	AE	x	20	10	8	4	2	1
0B	Day Alarm	AE	x	20	10	8	4	2	1
0C	Weekday Alarm	AE	x	x	x	x	4	2	1

• AE

This is the alarm control bit. There is an MSB for each register of minute alarm, hour alarm, day alarm, and day of week alarm. When this bit is set to 1, the appropriate register will be set to have the alarm unconditionally and regardless of the data, and this device is regarded as to have the circuitry working.

When the hour digit and the AE of data are set, alarm will occur at the specified minute regardless of the date and time. In other words the alarm will occur at the specified minute of every hour. Similarly, when minute and hour are set to AE, alarm occurs at the specified date. Therefore, by combining them in this way a highly versatile alarm can be set. When all of the bits are set to AE, no alarm will occur.

Additional information on the alarm function:

Even when the alarm is turned on for a long time, this device clears the flag when the alarm occurs once, and so no more further alarm will occur under the same condition. This means in the same day when the alarm condition is met, once the alarm flag is cleared and the alarm becomes unmatched the alarm will not occur unless new condition is met. Therefore, take note of this when using the flag.

8.2.5. CLKOUT frequency selection and timer registers

Address	Function	bit 7	bit 6	bit 5	bit 4	bit 3	bit 2	bit 1	bit 0
0D	CLKOUT frequency	FE	x	x	x	x	x	FD1	FD0
0E	Timer control	TE	x	x	x	x	x	TD1	TD0
0F	Timer	128	64	32	16	8	4	2	1

• Frequency output

Output frequency	FD1	FD0
32768 Hz	0	0
1024 Hz	0	1
32 Hz	1	0
1 Hz	1	1

* At the above setting, the output frequency of the CLKOUT pin can be selected.

Output is possible when the FE of MSB of the D register is 1. (When it stops, the CLKOUT pin goes to LOW.)

These output is controlled by CLKOE pin. When CLKOE input is LOW, CLKOUT output is inhibited.

• Timer control

Timer source clock	TD1	TD0
4096 Hz	0	0
64 Hz	0	1
1 second	1	0
1 minute	1	1

* At the above setting, the count down rate of the timer can be selected.

When the TE of MSB of the E register is 1, the timer count down starts, and stops when it becomes 0.

The F register data counts down at the set frequency and when it becomes zero TF is set.

When the F register is read, the data during count down is read out.

• Timer register

It sets the initial value of the timer's count down. The format is binary.

8.3. Access procedure

8.3.1. Characteristic of the I²C-BUS

I²C-BUS is a bi-directional interface that uses two (2) lines. This interface has two signal lines, which are SDA (data line) and SCL (clock line). Both of these lines are connected to the VDD line via the pull-up registers. All ports must be open drain or open collector on the I²C-BUS in order to be able to connect multiple devices on this bus using the AND-connection.

8.3.2. Bit transfer

The bit data transfer is executed for one bit on each one clock pulse of SCL line. When the device transmits the data, the data change should be executed while SCL line is at LOW. When the device receives the data, the data should be taken in while SCL is at HIGH.

8.3.3. Start condition and stop condition

When I²C-BUS is not interfacing, the two control lines keep at HIGH. When SDA changes from HIGH to LOW, this is defined as a start condition. After that, actual data transfer is executed. When SCL is at HIGH and when SDA changes from LOW to HIGH, this is defined as a stop condition.

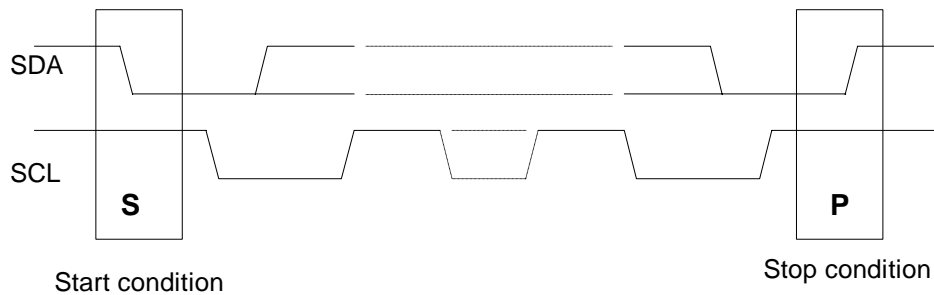

8.3.4. Slave address

The I²C-BUS devices do not have any chip select pins with the usual logic devices. All I²C-BUS devices have a fixed unique device number for each device built into them. The chip selection on the I²C-BUS is executed when the communication starts and this device number is sent from I²C-BUS as a slave address. The receiving device responds to the communication only if it matches the slave address.

The slave address is a 7-bit data which is made of a 4-bit fixed data (group 1) and 3-bits data (group 2). On the 8564, the data in group 1 is 1010 and in group 2 is 001.

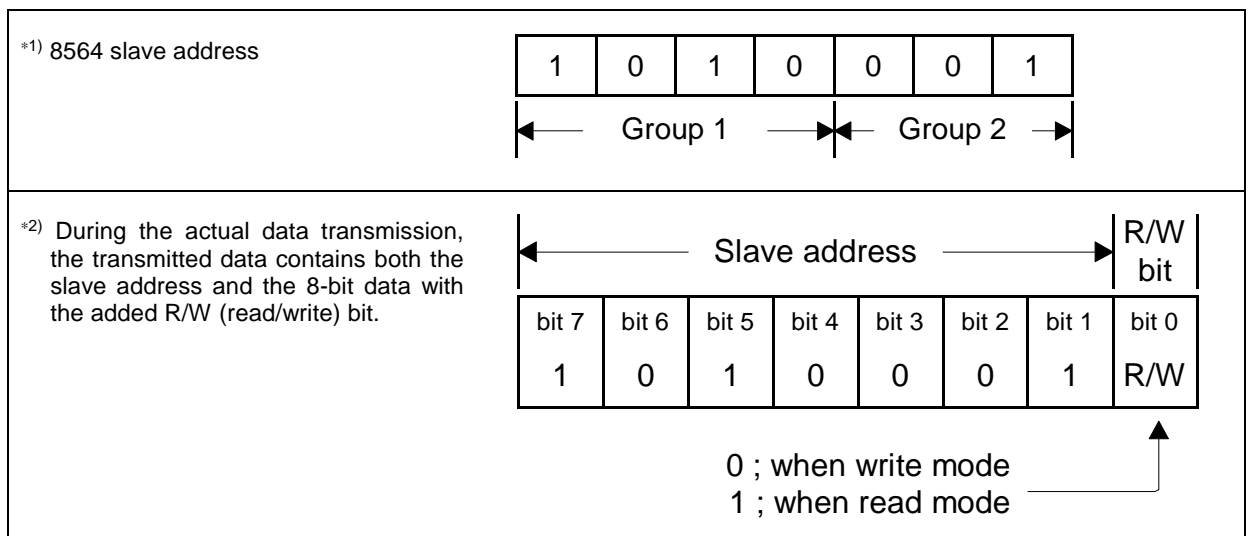

8.3.5. System structure

A master is defined a device that controls interfacing of messages, and a slave is defined as a device which is controlled by the master. A transmitter is defined as a device transmitting messages, and a receiver is defined as the one receiving messages. In the case of the 8564, controllers such as CPU are masters and the 8564 is a slave. Each device can be transmitter and receiver.

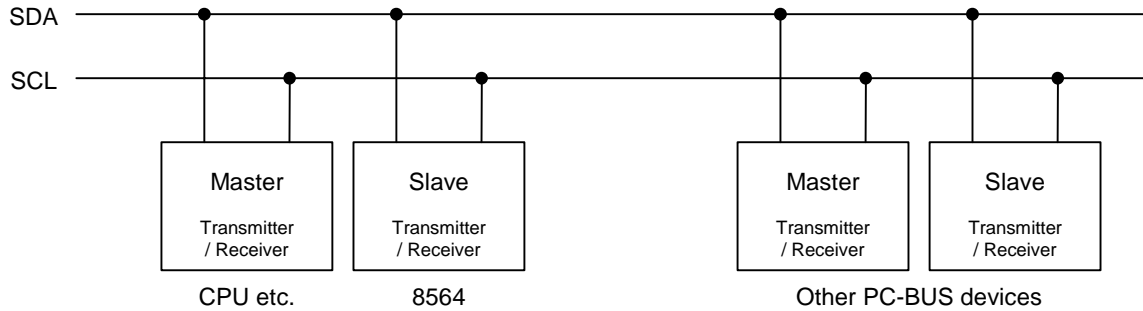

8.3.6. Acknowledge

There is no limit to the byte size of data transmitted between the start and stop conditions. For each byte during interfacing, the receiver (receiving end) generates an acknowledge bit to the transmitter (sending end) to confirm that it has received the data. Because the acknowledge bit is LOW active, the transmitter sets the SDA line to HIGH, and sends out a clock pulse for the acknowledge bit. If the receiver can correctly receive the 8-bit data from the transmitter, it will set the SDA line to LOW when the clock for the last bit is finished. Because the I²C-BUS lines are pulled-up, the SDA line of transmitter also turns to LOW. At this moment, the transmitter checks that the acknowledge has returned, and then continues to send out the next data. When the clock pulse for the acknowledge bit is finished, the receiver turns the SDA line to HIGH (release) and prepares to receive the next data.

When a master device is acting as a transmitter and acknowledge is confirmed from the receiver, if the next data is not sent/received but the stop condition is generated, it is possible to terminate the communication normally. When a master device is acting as a receiver and acknowledge bit is sent out as "1", it is possible to terminate the communication normally if the stop condition is generated.

8.3.7. I²C-BUS protocol

The following section describes the communications procedure where the master is CPU and the slave is the 8564.

(1) Procedure for write at specified address

The 8564 has an auto increment function of address. After the initial address is set, if only data continues to be sent, the receiving address on the 8564 is incremented by 1 byte. The procedure as follows:

- (1) The CPU sends out a start condition.
- (2) The CPU sends out the slave address of the 8564 and the R/W bit, in write mode.
- (3) Confirm acknowledge from the 8564.
- (4) The CPU sends out the write address to the 8564.
- (5) Confirm acknowledge from the 8564.
- (6) The CPU sends out the data for write to the address specified in step (4).
- (7) Confirm acknowledge from the 8564.
- (8) If necessary repeat steps (6) and (7). The address will be automatically incremented internally on the 8564.
- (9) The CPU sends out the stop condition.

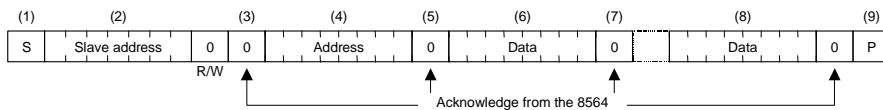

(2) Procedure for read at specified address

According to the write mode, after the address to read is written, the read mode is set and the actual data read. The procedure as follows:

- (1) The CPU sends out a start condition.
- (2) The CPU sends out the slave address of the 8564 and the R/W bit, in write mode.
- (3) Confirm acknowledge from the 8564.
- (4) The CPU sends out the address read out from the 8564.
- (5) Confirm acknowledge from the 8564.
- (6) The CPU sends out the start condition (stop condition is not sent.)
- (7) The CPU sends out the slave address of the 8564 and the R/W bit, in read mode.
- (8) Confirm acknowledge from the 8564.(From here on, the CPU acts as a receiver and the 8564 as a transmitter.)
- (9) Data at the address specified in step (4) is sent out from the 8564.
- (10) The CPU sends out acknowledge to the 8564.
- (11) If necessary repeat steps (9) and (10). The read address will be automatically incremented internally on the 8564.
- (12) The CPU sends out the stop condition.

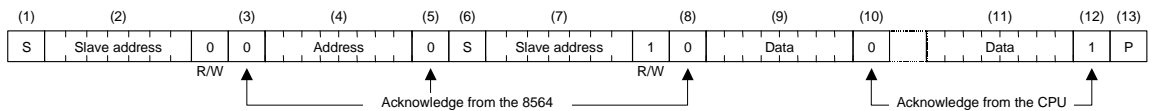

(3) Read procedure without specified address

Immediately after the read mode is set up, data can be read. In this case, the address is the address when the previous access ended, plus 1. The procedure is as follows:

- (1) The CPU sends out a start condition.
- (2) The CPU sends out the slave address of the 8564 and the R/W bit, in read mode.
- (3) Confirm acknowledge from the 8564.(From here on, the CPU acts as a receiver and the 8564 as a transmitter.)
- (4) Data at the last address in the previous access plus 1 is sent out from the 8564.
- (5) The CPU sends out acknowledge to the 8564.
- (6) If necessary repeat steps (4) and (5). The read address will be automatically incremented internally on the 8564.
- (7) The CPU sends out acknowledge of "1".
- (8) The CPU sends out the stop condition.

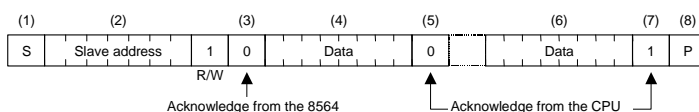

8.4. Typical connection to micro computers

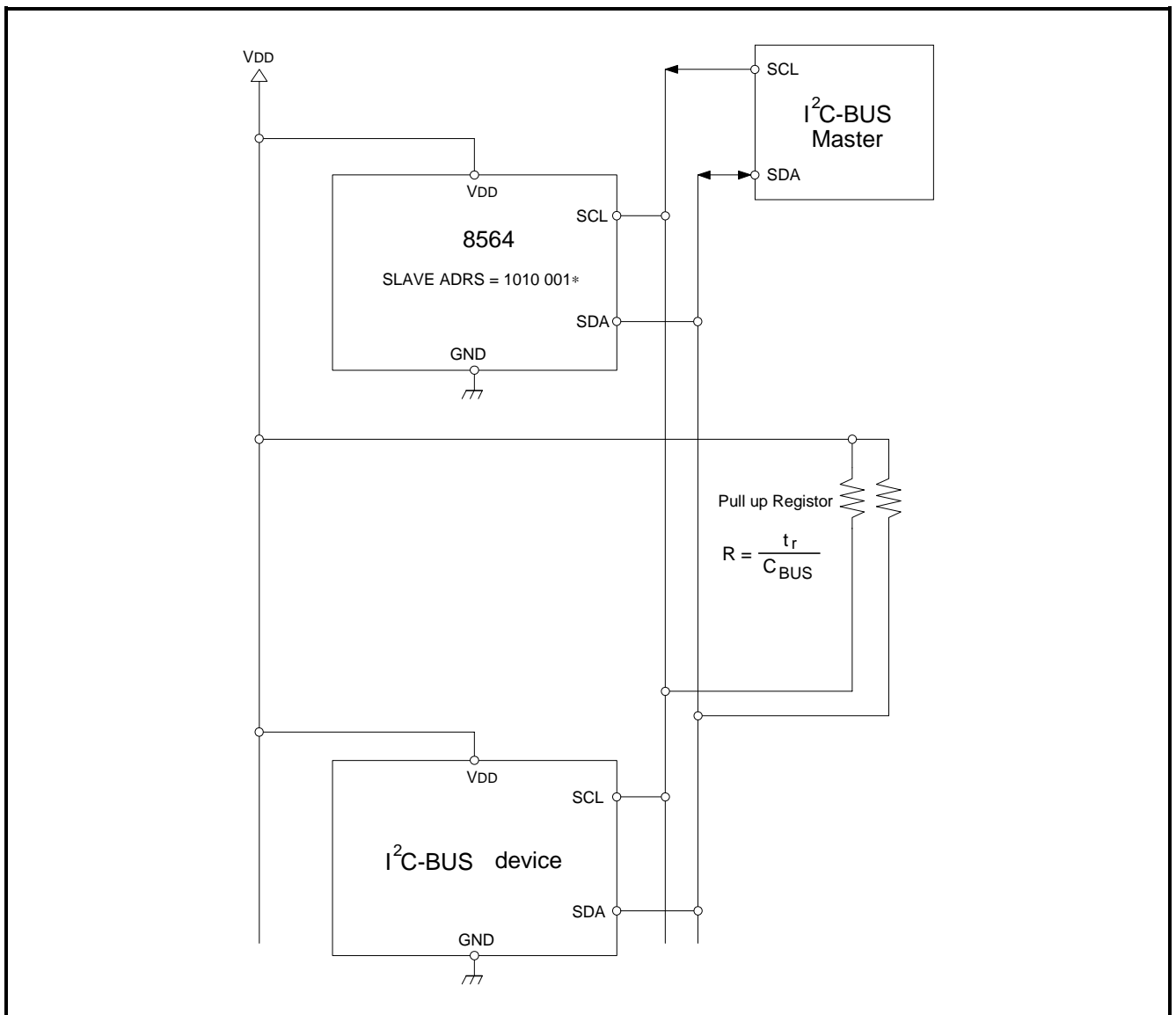

9. External dimensions / Marking layout

9.1. External dimensions

RTC - 8564 JE (VSOJ-20pin)

- External dimensions

- Recommended soldering pattern

Unit : mm

* The cylinder of the crystal oscillator can be seen in this area (back and front), but it has no affect on the performance of the device.

RTC - 8564 NB (SON-22pin)

- External dimensions

- Soldering pattern

Unit : mm

*1) The cylinder of the crystal oscillator can be seen in this area (back and front), but it has no affect on the performance of the device.

*2) In this area, At a parts side of electronic base, you must not do layout any signal line.

9.2. Marking layout

RTC - 8564 JE (VSOJ-20pin)

RTC - 8564 NB (SON-22pin)

* Contents displayed indicate the general markings and display, but are not the standards for the fonts, sizes and positioning.

10. Reference data

(1) Example of frequency and temperature characteristics

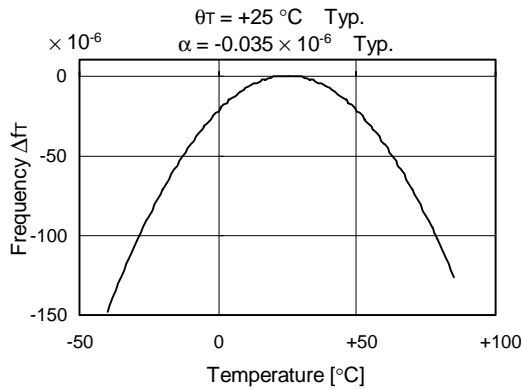

[Finding the frequency stability]

1. Frequency and temperature characteristics can be approximated using the following equations.

$$\Delta f_T = \alpha (\theta_T - \theta_X)^2$$

- Δf_T : Frequency deviation in any temperature
- α (1 / °C²) : Coefficient of secondary temperature ((-0.035±0.005) × 10⁻⁶ / °C²)
- θ_T (°C) : Ultimate temperature (+25±5 °C)
- θ_X (°C) : Any temperature

2. To determine overall clock accuracy, add the frequency precision and voltage characteristics.

$$\Delta f/f = \Delta f/f_0 + \Delta f_T + \Delta f_V$$

- $\Delta f/f$: Clock accuracy (stable frequency) in any temperature and voltage.
- $\Delta f/f_0$: Frequency precision
- Δf_T : Frequency deviation in any temperature.
- Δf_V : Frequency deviation in any voltage.

3. How to find the date difference

$$\text{Date Difference} = \Delta f/f \times 86400(\text{Sec})$$

* For example: $\Delta f/f = 11.574 \times 10^{-6}$ is an error of approximately 1 second/day.

(2) Example of frequency and voltage characteristics

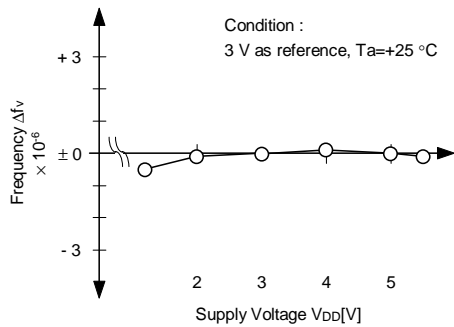

(3) Current and voltage consumption characteristics

(3-1) Current consumption when non-accessed (i) when CLKOUT=OFF

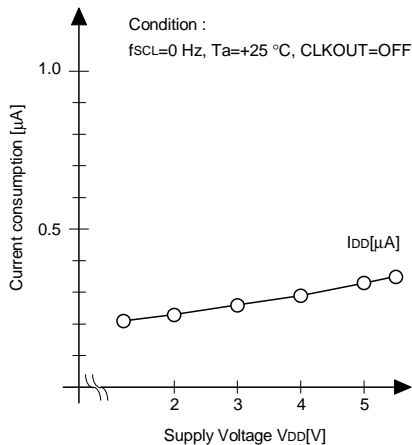

(3-2) Current consumption when non-accessed (ii) when CLKOUT=32.768kHz

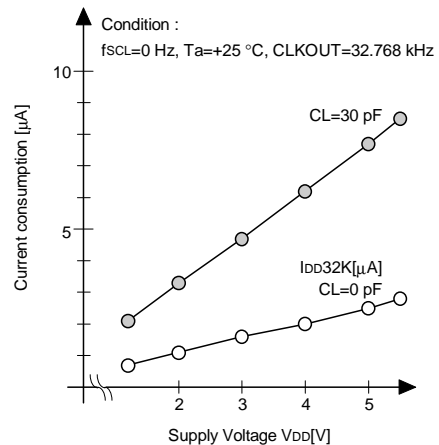

11. Application notes

11.1. Notes on handling

This module uses a C-MOS IC to realize low power consumption. Carefully note the following cautions when handling.

(1) Static electricity

While this module has built-in circuitry designed to protect it against electrostatic discharge, the chip could still be damaged by a large discharge of static electricity. Containers used for packing and transport should be constructed of conductive materials. In addition, only soldering irons, measurement circuits, and other such devices which do not leak high voltage should be used with this module, which should also be grounded when such devices are being used.

(2) Noise

If a signal with excessive external noise is applied to the power supply or input pins, the device may malfunction or "latch up." In order to ensure stable operation, connect a filter capacitor (preferably ceramic) of greater than 0.1F as close as possible to the power supply pins (between VDD and GNDs). Also, avoid placing any device that generates high level of electronic noise near this module.

* Do not connect signal lines to the shaded area in the figure shown in Fig. 1 and, if possible, embed this area in a GND land.

(3) Voltage levels of input pins

When the input pins are at the mid-level, this will cause increased current consumption and a reduced noise margin, and can impair the functioning of the device. Therefore, try as much as possible to apply the voltage level close to VDD or GND.

(4) Handling of unused pins

Since the input impedance of the input pins is extremely high, operating the device with these pins in the open circuit state can lead to unstable voltage level and malfunctions due to noise. Therefore, pull-up or pull-down resistors should be provided for all unused input pins.

(5) Storage

This device is Moisture Sensitive Level2 as defined by JEDEC J-STD-020A.

After bag is opened, devices that will be subjected to reflow solder or other high temperature process must be mounted within 6 months of factory conditions $\leq +30\text{ }^{\circ}\text{C} / 60\%$.

11.2. Notes on packaging

(1) Soldering heat resistance.

If the temperature within the package exceeds $+260$, the characteristics of the crystal oscillator will be degraded and it may be damaged. The reflow conditions within our reflow profile is recommended. Therefore, always check the mounting temperature and time before mounting this device. Also, check again if the mounting conditions are later changed.

* See Fig. 2 profile for our evaluation of Soldering heat resistance for reference.

(2) Mounting equipment

While this module can be used with general-purpose mounting equipment, the internal crystal oscillator may be damaged in some circumstances, depending on the equipment and conditions. Therefore, be sure to check this. In addition, if the mounting conditions are later changed, the same check should be performed again.

(3) Ultrasonic cleaning

Depending on the usage conditions, there is a possibility that the crystal oscillator will be damaged by resonance during ultrasonic cleaning. Since the conditions under which ultrasonic cleaning is carried out (the type of cleaner, power level, time, state of the inside of the cleaning vessel, etc.) vary widely, this device is not warranted against damage during ultrasonic cleaning.

(4) Mounting orientation

This device can be damaged if it is mounted in the wrong orientation. Always confirm the orientation of the device before mounting.

(5) Leakage between pins

Leakage between pins may occur if the power is turned on while the device has condensation or dirt on it. Make sure the device is dry and clean before supplying power to it.

(6) Marking

Depending on the cleaning fluid, there is a possibility that the marking will be damaged by it. It should be checked the affect in advance. Then do not touch the print side when wet.

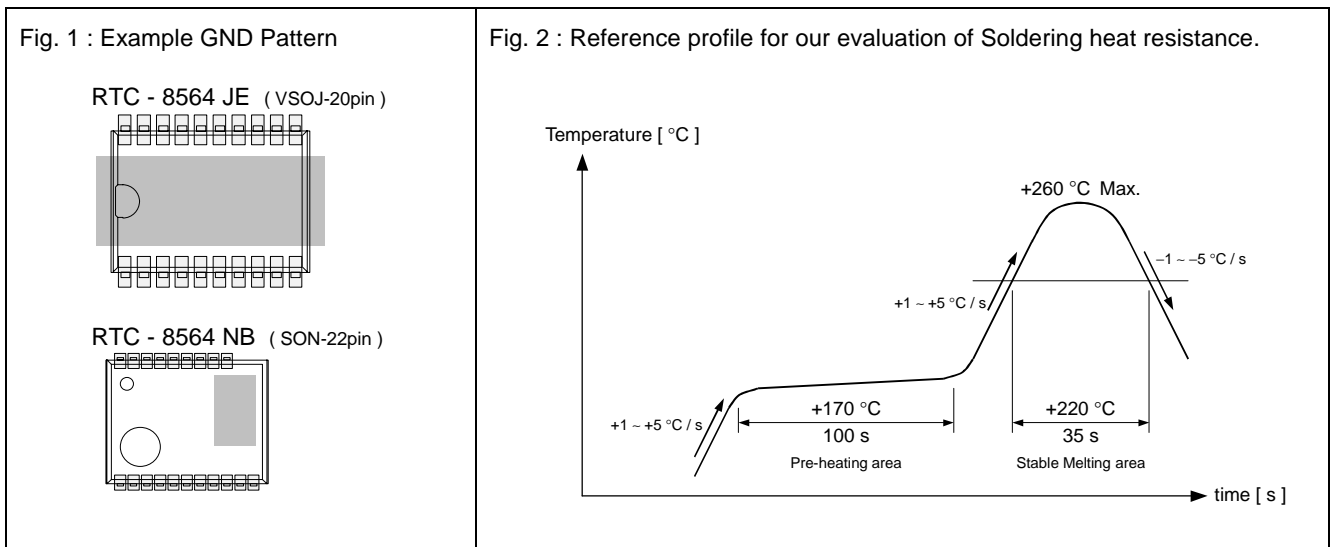

EPSON

Application Manual

Distributor

AMERICA

EPSON ELECTRONICS AMERICA, INC.

HEADQUARTER	150 River Oaks Parkway, San Jose, CA 95134, U.S.A. Phone: (1)800-228-3964 (Toll free) : (1)408-922-0200 (Main) Fax: (1)408-922-0238 http://www.eea.epson.com
Atlanta Office	3010 Royal Blvd. South, Ste. 170, Alpharetta, GA 30005, U.S.A. Phone: (1)877-332-0020 (Toll free) : (1)770-777-2078 (Main) Fax: (1)770-777-2637
Boston Office	301 Edgewater Place, Ste. 120, Wakefield, MA 01880, U.S.A. Phone: (1)800-922-7667 (Toll free) : (1)781-246-3600 (Main) Fax: (1)781-246-5443
Chicago Office	101 Virginia St., Ste. 290, Crystal Lake, IL 60014, U.S.A. Phone: (1)800-853-3588 (Toll free) : (1)815-455-7630 (Main) Fax: (1)815-455-7633
El Segundo Office	1960 E. Grand Ave., 2nd Floor, El Segundo, CA 90245, U.S.A. Phone: (1)800-249-7730 (Toll free) : (1)310-955-5300 (Main) Fax: (1)310-955-5400

EUROPE

EPSON EUROPE ELECTRONICS GmbH

HEADQUARTER	Riesstrasse 15, 80992 Munich, Germany Phone: (49)-(0)89-14005-0 Fax: (49)-(0)89-14005-110 http://www.epson-electronics.de
Düsseldorf Branch Office	Altstadtstrasse 176, 51379 Leverkusen, Germany Phone: (49)-(0)2171-5045-0 Fax: (49)-(0)2171-5045-10
UK & Ireland Branch Office	Unit 2.4, Doncastle House, Doncastle Road, Bracknell, Berkshire RG12 8PE, England Phone: (44)-(0)1344-381700 Fax: (44)-(0)1344-381701
French Branch Office	LP 915 Les Conquérants, 1 Avenue de l' Atlantique, Z.A. de Courtaboeuf 2 91976 Les Ulis Cedex, France Phone: (33)-(0)1-64862350 Fax: (33)-(0)1-64862355

ASIA

EPSON (CHINA) CO., LTD.

23F, Beijing Silver Tower 2# North RD DongSangHuan ChaoYang District, Beijing, China
Phone: (86) 10-6410-6655 Fax: (86) 10-6410-7319 <http://www.epson.com.cn>
4F, Bldg., 27, No.69, Gui Qing Road, Cao hejing, Shanghai, China
Phone: (86) 21-6485-0835 Fax: (86) 21-6485-0775

EPSON HONG KONG LTD.

20/F., Harbour Centre, 25 Harbour Road, Wanchai, Hong kong
Phone: (852) 2585-4600 Fax: (852) 2827-2152 <http://www.epson.com.hk>

EPSON ELECTRONIC TECHNOLOGY DEVELOPMENT (SHENZHEN) CO., LTD.

12/F, Dawning Mansion, #12 Keji South Road, Hi-Tech Park, Shenzhen, China
Phone: (86) 755-26993828 Fax: (86) 755-26993838

EPSON TAIWAN TECHNOLOGY & TRADING LTD.

14F, No.7, Song Ren Road, Taipei 110
Phone: (886) 2-8786-6688 Fax: (886)2-8786-6660 <http://www.epson.com.tw>

EPSON SINGAPORE PTE. LTD.

No.1, Temasek Avenue #36-00, Millenia Tower, Singapore 039192
Phone: (65) 337-7911 Fax: (65) 334-2716 <http://www.epson.com.sg>

SEIKO EPSON CORPORATION KOREA Office

50F, KLI 63 Building, 60 Yoido-dong, Youngdeungpo-Ku, Seoul, 150-763, Korea
Phone: (82) 2-784-6027 Fax: (82) 2-767-3677 <http://www.epson-device.co.kr>

Gumi Branch Office

6F, Good Morning Securities Bldg., 56, Songjeong-dong Gumi-City, Gyongsangbuk-Do,
730-090, Korea
Phone: (82) 54-454-6027 Fax: (82) 54-454-6093

SEIKO EPSON CORPORATION

ELECTRONIC DEVICE MARKETING DEPARTMENT

Electronic devices information on WWW server

<http://www.epsondevice.com>