

MicroBlaze – The Low-Cost and Flexible Processing Solution

Finding a processor to meet performance, feature, and cost targets can be very challenging in today's competitive environment. With the continued advances in FPGA technology features, increased performance and higher density devices, scalable processor systems can now be offered as an economical, superior alternative for real-time processing needs. A flexible processor system that's easy-to-use, area-efficient, optimized for cost-sensitive designs, and able to support you well into the future is delivered by the award-winning Xilinx MicroBlaze™ solution.

The Xilinx MicroBlaze processor, named to EDN's Hot 100 Products of 2005, is a 32-bit RISC "soft" core operating at up to 200 MHz on the Virtex™-4 FPGA and costs less than 50 cents to implement in the Spartan™-3E FPGA. Because the processor is a soft core, you can choose from any combination of highly customizable features that will bring your products to market faster, extend your product's life cycle, and avoid processor obsolescence.



www.edn.com



The MicroBlaze Advantage

Xilinx unleashes the potential of embedded FPGA designs with the award-winning MicroBlaze soft processor solution. The MicroBlaze core is a 3-stage pipeline 32-bit RISC Harvard architecture soft processor core with 32 general purpose registers, ALU, and a rich instruction set optimized for embedded applications. It supports both on-chip block RAM and/or external memory. With the MicroBlaze soft processor solution, you have complete flexibility to select any combination of peripherals, memory and interface features that you need to give you the best system performance at the lowest cost on a single FPGA.

Hardware Acceleration using Fast Simplex Link

The MicroBlaze Fast Simplex Link (FSL) lets you connect hardware co-processors to accelerate time-critical algorithms. The FSL channels are dedicated uni-directional point-to-point data streaming interfaces. Each FSL channel provides a low latency interface to the processor pipeline making them ideal for extending the processor's execution unit with custom hardware accelerators.

Floating-Point Unit Support

MicroBlaze introduces an integrated single precision, IEEE-754 compatible Floating Point Unit (FPU) option optimized for embedded applications such as industrial control, automotive, and office automation. The MicroBlaze FPU provides designers with a processor tailored to execute both integer and floating point operations.

Hardware Configurability

The MicroBlaze processor solution provides a high level of configurability to tailor the processor sub-system to the exact needs of the target embedded application. Configurable features such as: the barrel shifter, divider, multiplier, instruction and data caches, FPU, FSL interfaces, hardware debug logic, and the hardware exceptions, provide great flexibility but does not add to the cost if they are not used.

Award-Winning Platform Studio Tool Suite

The Embedded Development Kit (EDK) is an all encompassing solution for designing embedded programmable systems. This pre-configured kit includes the award-winning Platform Studio™ Tool Suite, the MicroBlaze soft processor core as well as all the documentation and soft peripheral IP that you require for designing FPGA-based embedded processor systems.

Embedded Development Kit and Platform Studio Tool Suite

For development, Xilinx offers the Embedded Development Kit (EDK), which is the common design environment for both MicroBlaze and PowerPC-based embedded systems. The EDK is a set of microprocessor design tools and common software platforms, such as device drivers and protocol stacks. The EDK includes the Platform Studio tool suite, the MicroBlaze core, and a library of peripheral IP cores.

Using these tools, design engineers can define the processor subsystem hardware and configure the software platform, including generating a Board Support Package (BSP) for a variety of development boards. Platform Studio Software Development Kit (SDK) is based on the Eclipse open-source C development tool kit and includes a full-featured development environment and a feature-rich GUI debugger. The MicroBlaze processor is supported by the GNU compiler and debugger tools. The debugger connects the MicroBlaze via JTAG. For debugging visibility and control over the embedded system, design engineers can add the ChipScope Pro™ verification tools from Xilinx, which are integrated into the hardware/software debug capabilities of the EDK.

Device Family	Max Clock Frequency	Max Dhrystone 2.1 Performance
Virtex-4	200 MHz	166 DMIPS
Virtex-II Pro	170 MHz	138 DMIPS
Spartan-3	100 MHz	92 DMIPS

Note: The maximum clock frequency and maximum Dhrystone 2.1 performance benchmarks are not based on the same system. Depending on the configured options, the MicroBlaze soft processor core size is about 900 – 2600 LUTs.

MicroBlaze Hardware Options and Configurable Blocks

Hardware Functions

- Hardware Barrel Shifter
- Hardware Divider
- Machine Status Set and Clear Instructions
- Hardware Exception Support
- Pattern Compare Instructions
- Floating-Point Unit (FPU)
- Hardware Multiplier Enable
- Hardware Debug Logic

Cache and Cache Interface

- Data Cache (D-Cache)
- Instruction Cache (I-Cache)
- Instruction-side Xilinx Cache Link (IXCL)
- Data-side Xilinx Cache Link (DXCL)

Bus Infrastructure

- Data-side On-chip Peripheral Bus (DOPB)
- Instruction-side On-chip Peripheral Bus (IOPB)
- Data-side Local Memory Bus (DLMB)
- Instruction-side Local Memory Bus (ILMB)
- Fast Simplex Link (FSL)

Take the Next Step

Visit our website www.xilinx.com/microblaze for more information .
To order your Embedded Development Kit visit www.xilinx.com/edk.

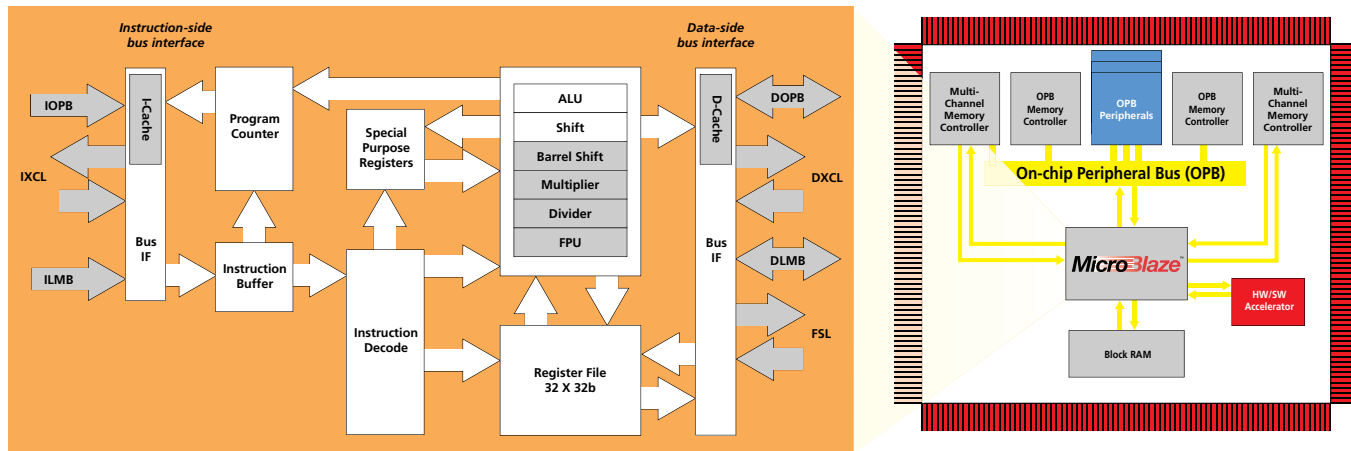

□ Basic Processor Functions □ Configurable Functions ■ Designer Defined Blocks ■ Peripherals – Xilinx or 3rd Party or Designer Defined

Corporate Headquarters

Xilinx, Inc.
2100 Logic Drive
San Jose, CA 95124
Tel: (408) 559-7778
Fax: (408) 559-7114
Web: www.xilinx.com

European Headquarters

Xilinx
Citywest Business Campus
Saggart,
Co. Dublin
Ireland
Tel: +353-1-464-0311
Fax: +353-1-464-0324
Web: www.xilinx.com

Japan

Xilinx, K.K.
Shinjuku Square Tower 18F
6-22-1 Nishi-Shinjuku
Shinjuku-ku, Tokyo
163-1118, Japan
Tel: 81-3-5321-7711
Fax: 81-3-5321-7765
Web: www.xilinx.co.jp

Asia Pacific

Xilinx Asia Pacific Pte. Ltd.
No. 3 Changi Business Park Vista, #04-01
Singapore 486051
Tel: (65) 6544-8999
Fax: (65) 6789-8886
RCB no: 20-0312557-M
Web: www.xilinx.com

Distributed By:

FORTUNE 2005
100 BEST COMPANIES TO WORK FOR

XILINX
The Programmable Logic Company™

© 2006 Xilinx, Inc. All rights reserved. XILINX, the Xilinx logo, and other designated brands included herein are trademarks of Xilinx, Inc. PowerPC is a trademark of IBM, Inc. All other trademarks are the property of their respective owners.