



INDUSTRY'S BEST PRICE-PERFORMANCE
FPGAS WITH LOWER POWER

INTRODUCING A NEW CLASS OF FPGAS: AN IDEAL BALANCE OF INTEGRATION, PRICE, PERFORMANCE, AND POWER

➤ Market Challenges

- Stringent demands for higher performance
- Power is also paramount (as much as 40% of operating expenses)
- System complexity calls for more highly integrated silicon devices
- Only highly differentiated products can stand out in today's market
- Increasing competition requires lowering costs
- Pressures to speed time to production make ASSPs and ASICs less practical

➤ The Solution: Xilinx Kintex-7 FPGAs

- A new class of device, with twice the price-performance at a lower price point
- 28nm high-κ metal gate (HKMG) process technology and a High-Performance, Low-Power (HPL) approach that drive up power efficiency
- A balanced design, optimized and packaged for performance, power, cost, and time to market for high-growth applications
- The flexibility and time-savings of programmability and Targeted Design Platforms, for lower development time and costs
- Unified architecture with AMBA® Advanced extensible Interface 4 (AXI4) for plug-and-play IP that facilitates reuse and portability
- Part of the industry's most versatile series for fast, easy retargeting to higher-density or lower-cost devices

Industry's Best Price-Performance

With the introduction of the world's first 28nm FPGAs, Xilinx gives designers the broadest range of programmable platforms including the versatility of a new class of devices. Doubling the price-performance and cutting power consumption and cost in half makes the Xilinx Kintex™-7 FPGAs the clear choice for today's fast-growth applications such as wireless communications. Designers can take advantage of a family of devices with exceptional performance and connectivity, at price points previously limited to only the highest-volume applications.

Highly Integrated, High-Speed Connectivity

Kintex-7 FPGAs let designers build in superior bandwidth and 12-bit digitally programmable analog while meeting cost and power requirements. Unprecedented 144GMACS digital signal processor (DSP) power makes the versatile Kintex-7 devices an excellent option for applications such as portable ultrasound equipment and next-generation communications. Kintex-7 FPGAs deliver peak serial bandwidth (full duplex) of 800Gbps and include CPRI/OBSAI IP cores (9.8Gbps) optimized for today's distributed baseband architectures. The programmable Kintex-7 devices can also be easily reconfigured to support multiple air interfaces such as LTE, WiMAX, and WCDMA. For interfacing to host systems, the Kintex-7 FPGA family provides built-in support for eight-channels of PCI Express (Gen1/Gen2).

The highly efficient and affordable devices also enable designers to address connectivity and throughput requirements while minimizing part counts. The 72-bit, 1,833Mbps Kintex-7 memory interface supports single-memory-buffer designs instead of the two- or four-buffer designs required with other devices. Similarly, a single Kintex-7 device can process video at rates that enable a single-chip implementation of a video over IP gateway that can support 12 3G channels over a 4-channel 10 Gigabit Ethernet bridge.

The Strength of a Unified Architecture

All 7 series FPGA families leverage the Xilinx unified architecture to protect IP investments and make it easy to migrate 6 series designs. With common elements including logic fabric, Block RAM, DSP, clocking, Agile Mixed Signal (AMS), and more, the unified architecture also facilitates rapid retargeting within the 7 series. For migrations and new projects alike, the Kintex-7 architecture dramatically reduces development times and lets designers focus on product differentiation.

Key Capabilities Overview

Twice the Price-Performance, Lower Cost

- Many performance-boosting innovations including industry-leading 1,866Mbps memory interface; 639MHz DSP48E1 slices with high-performance filtering capabilities; six-input look-up table
- 1833Mbps memory interfaces
- LVDS connectivity at 1.6G
- Up to 1,920 DSP slices
- Package optimized to line rate performance

Memory Controller Innovations

- Dedicated hard IP implementation of the memory Phy, for simplified interfacing to external DDR memory
- A flexible, soft controller enabled by high-performance logic for calibration, access methods, and system interfaces
- High-speed PCI Express hard and soft IP
- Integrated hard IP for PCI Express, with full support for PCI Express endpoint and root port configurations
- Hard IP support for up to eight PCI Express Gen1 and Gen2 channels
- Soft IP support for up to eight PCI Express Gen3 channels

Maximize Connectivity and Stay Within Budget

- Kintex-7 FPGAs let designers choose a package with the right combination of price and performance for the application
- Family price points each maximize throughput (6.6Gbps and 12.5Gbps transceivers)
- Maximize performance with regular flip-chip BGA packaging offering highest signal integrity and up to 32 high-speed GTX transceivers (12.5Gbps line rates)
- Minimize costs with bare-die flip-chip BGA packaging that delivers high signal integrity and robust thermal characteristics (up to 6.6Gbps line rates)

Half the Power Consumption

- HPL process cuts power in half compared to alternative 28nm High-Performance (HP) process
- Low 1.0V core voltage (optional 0.9V core voltage option for some devices) translates into lower system power, lower cooling required, and more "green" designs
- Additional power reductions from intelligent clock gating and fifth-generation partial reconfiguration

FOCUS ON DIFFERENTIATION

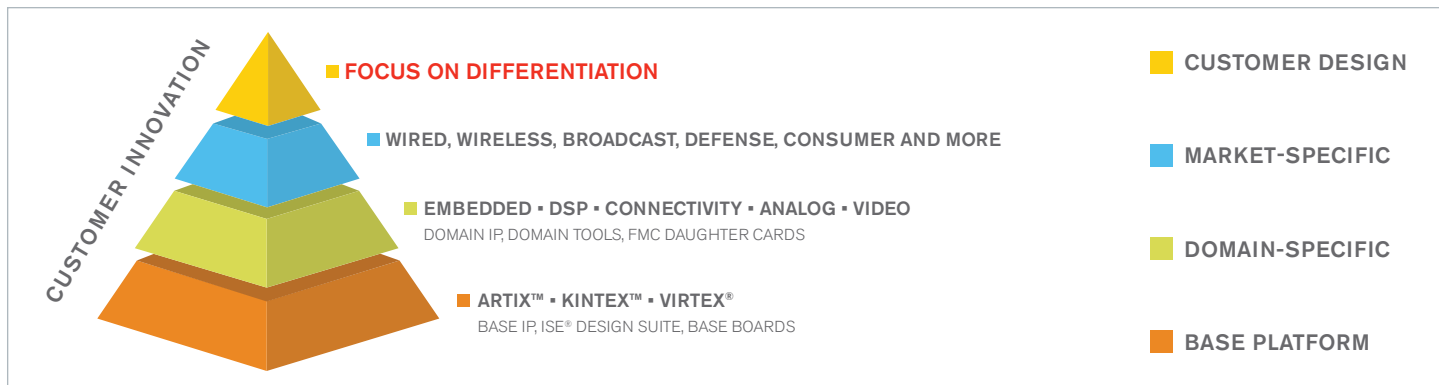

Maximizing Productivity with Targeted Design Platforms

Xilinx Targeted Design Platforms are the industry's most comprehensive development kits, complete with boards, tools, IP cores, reference designs and FPGA Mezzanine Card (FMC) support. The kits enable designers to begin application development immediately and boost productivity while accelerating access to advanced functionality with pre-verified reference designs. Combined with a full-featured evaluation board and Xilinx ISE Design Suite software, the reference designs also facilitate the integration of solutions from an ecosystem of readily available third-party add-on hardware and IP.

Our base kit, the Kintex-7 FPGA KC705 Evaluation Kit, provides a flexible framework for designing higher-level systems that require DDR3, Gigabit Ethernet, PCI Express, and other serial connectivity. Our first domain kit, the Kintex-7 FPGA DSP Kit, includes an integrated high-speed analog FPGA mezzanine card (FMC) to interface to real-world signals.

Enabling Next-Generation Systems

COMMUNICATIONS: SINGLE-CHIP LTE BASEBAND (2 X 4 MIMO)

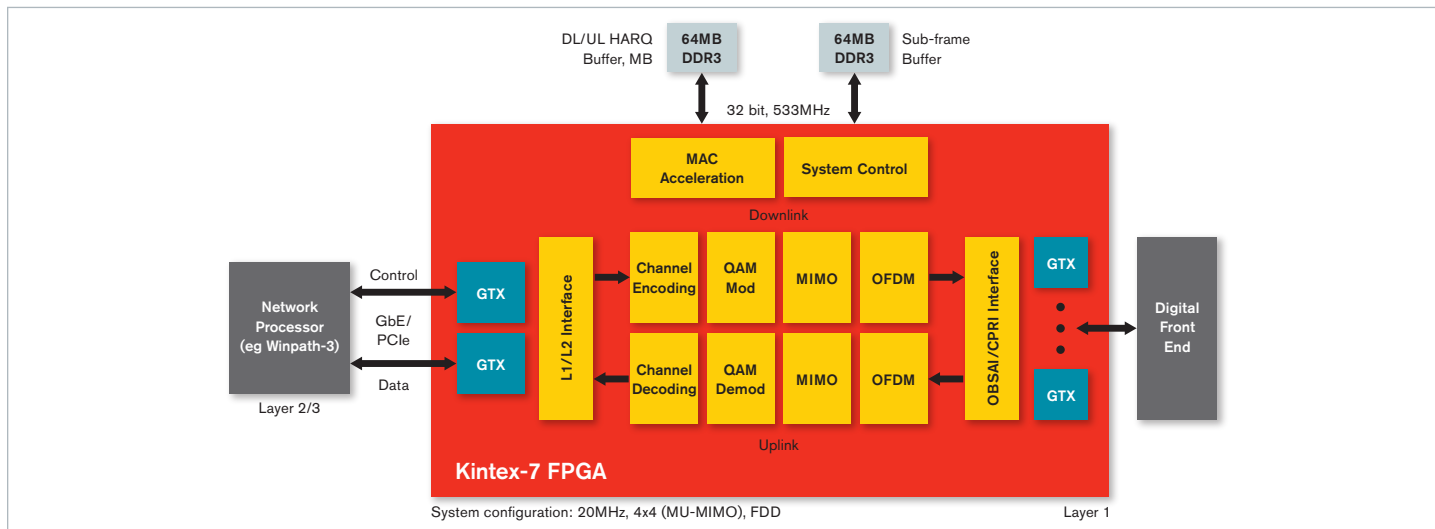

Kintex-7 FPGAs offer the best price-performance so designers can meet stringent latency requirements for LTE baseband processing in a common platform.

- Programmability enables a cost-effective common platform supporting multiple air interfaces such as LTE, WiMAX, and WCDMA
- Reduce total cost of ownership with the ability to scale and reuse designs from picocell to macrocell
- 3x capacity at the same cost of previous-generation FPGAs while consuming 40% less power
- Support for 9.8Gbps CPRI/OBSAI for high throughput
- Support for 6.144Gbps CPRI/OBSAI in a low-cost package option

MEDICAL: PORTABLE ULTRASOUND

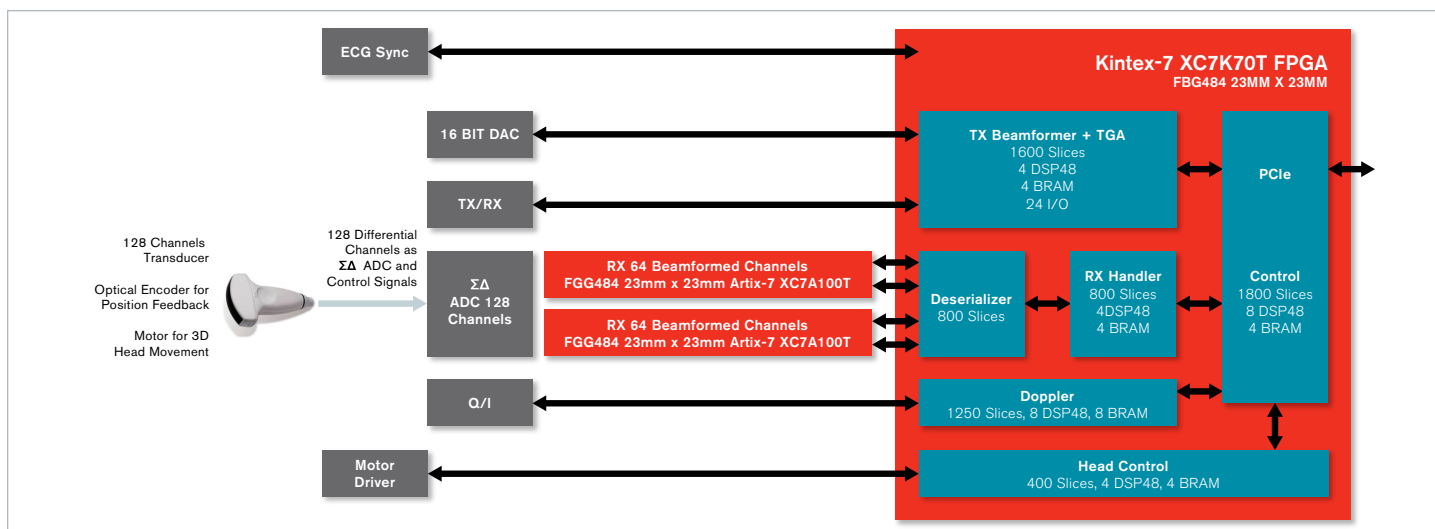

Support for 6.144Gbps CPRI/OBSAI in a low-cost package option High I/O bandwidth and 144GMACS DSP processing power in chip-scale packaging make the Kintex-7 70T FPGA highly effective for both front- and back-end ultrasound processing. Designers can deploy a fully programmable 128-channel ultrasound implementation that scales up to 196 or 256 channels for high-end cart solutions or down to 64 or 32 channels for hand-held solutions.

- 128-channel implementation in a modular set of five Kintex-7 70T FPGAs offers 44% lower power, 45% lower cost, and 57% smaller form factor compared to previous-generation FPGAs
- Kintex-7 70T FPGAs offer 144GMACS from 240 DSP slices (288GMACS for symmetric filters)
- Built-in support for eight PCI Express Gen1/Gen2 channels enables high-bandwidth interface to host system
- Chip-scale packaging for small form factor

BROADCASTING: VIDEO OVER IP GATEWAY

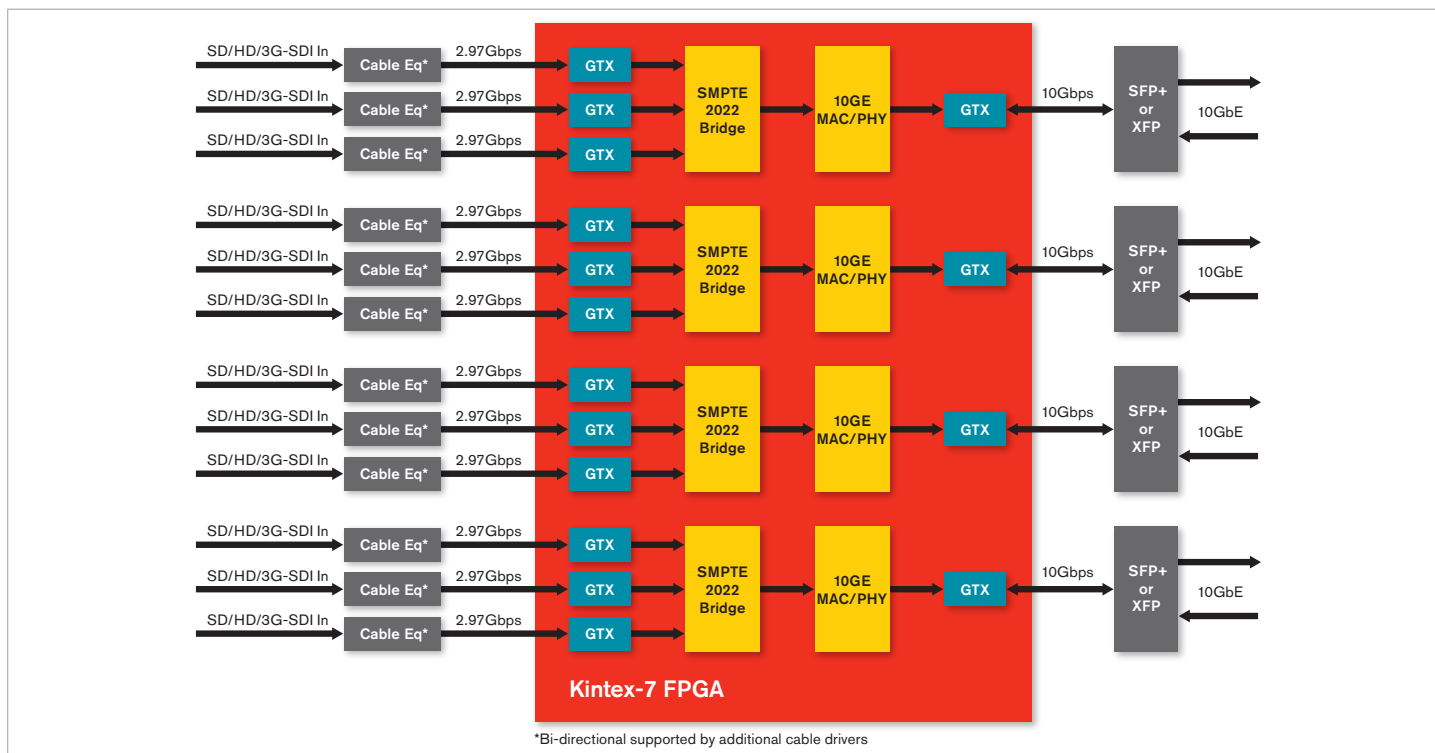

Kintex-7 FPGAs enable cost-effective, low-power bridging of the serial digital interface (SDI) protocol onto IP technology for long-distance WAN transport to link local studios/live events, broadcast facilities, and satellite uplink stations using standard IP networks.

- Reduce power by 64% and reduce cost by 85% with a single XC7K160T FPGA implementation of a 12x 3G-SDI over 4x10GbE bridge compared to the equivalent function implemented in two Virtex-6 XC6L130T devices
- Reduce cost further with high-bandwidth interfaces that shrink BOM: 72-bit x 1,600Mbps DDR3 memory interface capability enables a single memory buffer that would require two or four memory buffers in previous-generation FPGAs

Take the NEXT STEP

Download the latest version of ISE Design Suite tools: www.xilinx.com/ise

For more information visit: www.xilinx.com/kintex7

Corporate Headquarters

Xilinx, Inc.
2100 Logic Drive
San Jose, CA 95124
USA
Tel: 408-559-7778
www.xilinx.com

Europe

Xilinx Europe
One Logic Drive
Citywest Business Campus
Saggart, County Dublin
Ireland
Tel: +353-1-464-0311
www.xilinx.com

Japan

Xilinx K.K.
Art Village Osaki Central Tower 4F
1-2-2 Osaki, Shinagawa-ku
Tokyo 141-0032 Japan
Tel: +81-3-6744-7777
japan.xilinx.com

Asia Pacific Pte. Ltd.

Xilinx, Asia Pacific
5 Changi Business Park
Singapore 486040
Tel: +65-6407-3000
www.xilinx.com

