

Driving Home Multimedia

Infotainment hits the road with affordable in-car networking.



by Carl Rohrer
Senior Design Engineer
Xilinx, Inc.
carl.rohrer@xilinx.com

Per square foot, you probably have more multimedia in your car than you do in your house. There are the two LCD screens for the kids in the backseat, controlled by a DVD player or a video game console. An audio system is powered by the latest MP3 player. There's the navigation system and even broadcast television in some luxury vehicles. Plus, you've probably got more speakers in your car than in a high-end surround sound system. It's no wonder there are so many distracted drivers on the road. What you need is a single, simple control interface; what manufacturers need is a sophisticated network.

MOST (Media Oriented Systems Transport) is a network standard on the rise among automakers and automotive suppliers. It provides one single interface for managing all of your multimedia devices. Its strength resides in the ability to handle multiple streams of data intended for different targets without losing congruity. On-time data: this is something even your home network cannot guarantee.

In this article, I'll explore the MOST network and demonstrate the flexibility of the Xilinx® MOST solution.

Under the Hood

The MOST network runs on optical fiber, typically in a ring topology. The clock and serialized data are bi-phase encoded, requiring just one single piece of fiber to be routed. MOST offers up to 25 Mbps of

aggregate bandwidth, far surpassing classical automobile networks. In other words, you could play 15 distinct audio streams at the same time.

Each multimedia device is represented by a node in the ring. A typical MOST network will have between three and 10 nodes. There is one timing master that drives the system clock and generates frames, or 64-byte sequences, of data. The remaining nodes all act as slaves. One node acts as the user control interface, or MMI (man machine interface). Often, this is also the timing master. Figure 1 illustrates a basic MOST ring.

The main payload comprises 60 bytes within the 64-byte frame. This payload is made up of synchronous and asynchronous fields. The synchronous field is used for streaming contiguous data; audio and video fall under this category. The asynchronous field is used for sporadic data transfers in applications such as Internet access, navigation data transfer, and phone book synchronization. Also, this channel could be used for firmware upgrades of the control units.

A node may send or receive data during its assigned time slots. A time slot – one synchronous byte within the payload – is dynamically allocated between a requesting node and the timing master. Typically, one node will transmit data onto a time slot, while any number of other nodes will collect the data from that time slot.

The boundary between synchronous and asynchronous is dynamically controlled by the timing master. In any given frame, the synchronous field may be from 4 to 60 bytes, leaving the remainder of the 60 bytes to the asynchronous field.

The remaining four bytes of the frame are used for header, trailer, and control information. The header contains a preamble for frame alignment. The trailer, among other things, does a parity check. The control field is used for network-related messaging. These messages may be low level, like the allocation and de-allocation of time slots. Conversely, they can be high-level application messages sent from the operator, such as play next track, volume control, or repeat play.

Getting More Out of MOST

Instead of having an external MOST controller chip connected to a microcontroller or DSP, you can integrate all of your components into one single FPGA. Fewer external components and reduced PCB space translates into cost savings for developers.

Xilinx offers a fully parameterizable MOST Network Interface Controller (NIC) IP core. You can customize the core to be a timing master or reduce logic with a slave-only configuration. The core is controlled by a full suite of registers accessible through an on-chip peripheral (OPB) interface. The OPB interface works seamlessly with the Xilinx MicroBlaze™ 32-bit RISC processor core included in Xilinx Platform Studio.

A full set of low-level driver files are already available in C source code. The drivers provide a series of functions for accessing the register space, handling interrupts, and streaming data to the core. Mocean Laboratories AB provides MOST network services for the IP core for a complete network stack, leaving you only to write your desired application.

Unique to the Xilinx MOST NIC is a streaming port interface that allows data to be preprocessed in real time. It is ideal for bolting on data filters or encryption/decryption modules. This LocalLink interface, a Xilinx standard, will significantly reduce traffic on the processor and processor bus by offloading dedicated procedures. It's versatile too. You can read or write data in either the receive or transmit directions. Best of all, if you don't use it, the Xilinx implementation tools will remove the unnecessary logic, allowing you to conserve resources and fit your design into a smaller device.

Synchronous data can be transmitted and received on either the streaming port or the OPB interface. Regardless of the method you choose and how many time slots you have assigned, the core formats data into 32-bit words for these user interfaces. Through register definitions, the core accumulates received time slot data that is deposited through one of 16 logical channels. The reverse is true in the transmit direction. The use of these logical channels allows for 16 distinct streams of data in each direction.

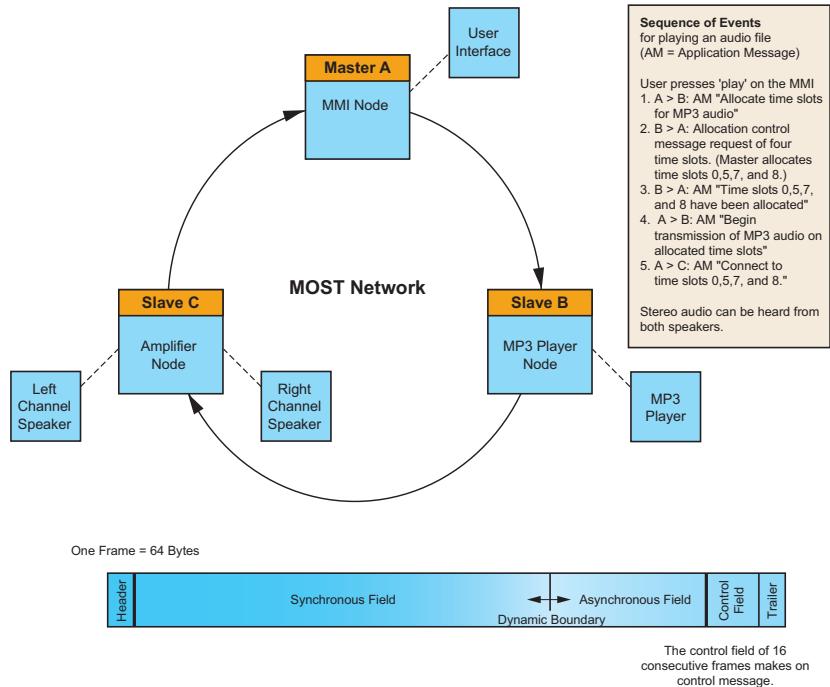

Figure 1 – An example MOST automotive ring

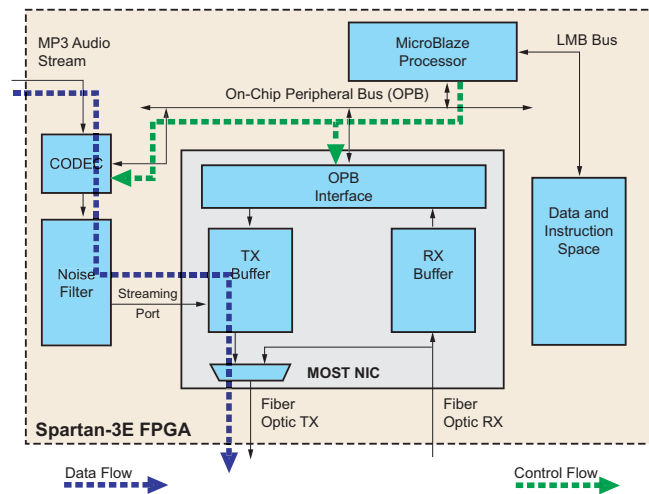

Figure 2 – Theoretical MP3 node

The Xilinx MOST NIC core is flexible. Consider the MOST ring in Figure 1 again, which illustrates how you might design each node with the Xilinx MOST NIC. You could configure the core as a timing master to operate as the MMI. As the timing master, the core will send and receive control messages that regulate ring operation. This node will also send application messages, also through the control field, on behalf of the user. You can also use the driver files and Mocean's

network services on top of MicroBlaze for event scheduling.

You can turn the MP3 player into a high-end audio feed by adding a noise filter bolt-on to eliminate the artifacts of audio compression. The payload data can run from the codec through the noise filter directly into the streaming port, completely avoiding the OPB bus. Once again, you can use the MicroBlaze embedded processor for interrupt handling and event scheduling. Figure 2 depicts the block diagram of such a design.

For the amplifier, imagine a minimal design that simply receives data and forwards it to the speakers. Instead of using an embedded processor, as in the MP3 node, you can implement a smaller user design capable of full network negotiation and data collection. Such a compact design may be placed in a smaller device for further cost savings.

Conclusion

If you drive a high-end European automobile, you may already have a MOST network. It has gained acceptance as one of the de facto standards for automotive networking among European-based OEMs. Those of us driving more affordable cars will not have too long to wait, however. With the advent of competition, this once private standard is

becoming more affordable for cost-conscious automakers.

As demand grows for larger amounts of data – from audio to video, telematics, and navigation-based applications – the MOST network technology has plans to grow as well. The next-generation standard, MOST 50, has already been defined and offers twice as much bandwidth as the original. At the time of this writing, the MOST Cooperative is planning a third-generation network expected to reach data rates of 150

Mbps and beyond. These updates will eventually increase available application bandwidth by more than an order of magnitude and are expected to support both a copper and optical physical medium.

The Xilinx MOST NIC is available today in CORE Generator™ software. At six block RAMs and about 2,600 slices, it will fit in a mid-sized Spartan™-3E device with room to spare for an embedded processor, peripherals, buffers, and your own custom circuitry. ●●

TAKE THE NEXT STEP (Digital Edition: www.xcellpublications.com/subscribe/)

- Read the MOST NIC data sheet for more details
- Contact your Xilinx FAE to test-drive the MOST NIC core

Stay Ahead!

Xilinx® Virtex™-5 LX FPGA
A new generation of performance

Analog I/O, Camera Link, LVDS, FPDP-II, RS485/422 & L-Band Receiver options
Fast, integrated I/O without bottlenecks

Multiple banks of fast memory
DSP & I/O optimized memory architecture

PCI-X Interface with multiple DMA controllers
More than 1GB/s bandwidth to host

Libraries and Example Code
Easy to use with head-start time-to-market

with the PMC-FPGA05 Range of Virtex-5 based PMCs

Processing & FPGA Input/Output Data Recorders & Storage Bus Analyzers

For more information, please visit <http://virtex5.vmetro.com> or call (281) 584-0728

VIMETRO
Innovation deployed