



XAPP502 (v1.5) December 3, 2007

Using a Microprocessor to Configure Xilinx FPGAs via Slave Serial or SelectMAP Mode

Authors: Mark Ng and Mike Peattie.

Summary

With embedded systems becoming more popular, many designers want to reduce their component count and increase flexibility. To accomplish both of these goals, a microprocessor already available in the system can be used to configure an FPGA. This application note provides a thorough discussion of FPGA configuration via a microprocessor, covering Virtex™ and Spartan™ FPGA families. Also, this application note presents a system-level model using a Xilinx Complex Programmable Logic Device (CPLD) to implement an interface to the FPGA configuration pins. C code is included to illustrate an example application using either Slave Serial or SelectMAP mode. CPLD design files are also included to illustrate a possible synchronous interface between the processor and the FPGA.

System Overview

Today's systems demand greater functionality in less space and at reduced cost. In addition, each generation of Xilinx FPGAs delivers higher performance and increased capabilities. Although the Platform Flash PROMs provide an easy-to-use, pre-built configuration solution for Xilinx FPGAs, an embedded processor-based configuration solution can allow for advanced FPGA configuration applications and reduce board real estate requirements, assuming that an external, embedded processor with sufficient memory is already a pre-requisite for the system.

This application note describes a technique for configuring an FPGA from an embedded processor. Three common components are required: an embedded microprocessor, some non-volatile memory, and a CPLD. Cost, as well as real estate, can be reduced if the function of a dedicated configuration device, such as a PROM, can be integrated within these three components. A system diagram is shown in [Figure 1](#).

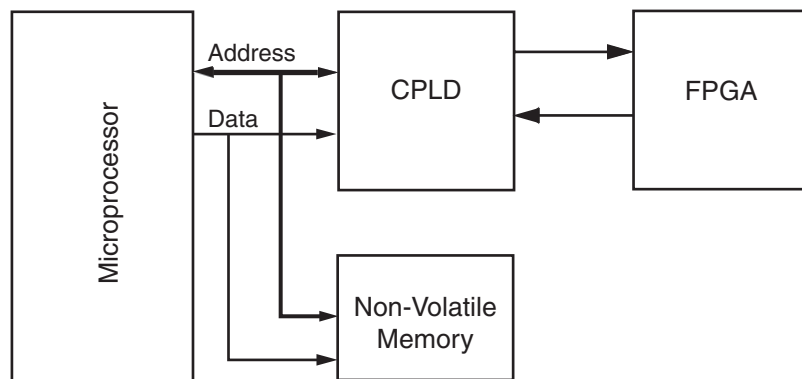

x502_01_110102

Figure 1: System Diagram

Note: Some systems might not require a CPLD if the microprocessor has a sufficient number of general-purpose I/O (GPIO) pins available. For these systems, the Xilinx FPGA can be configured directly by the microprocessor. For this type of configuration, this application note still applies. The overall configuration flow remains the same, but the user must modify the source code so that the microprocessor strobbs its GPIO pins instead of its address and data bus.

Instead of using a dedicated PROM, the configuration bitstream can be loaded into unused portions of non-volatile system memory. Furthermore, a microprocessor, whose primary purpose is to perform other tasks, can also be used to coordinate the loading of configuration data into a Xilinx FPGA device. Unused register bits of a CPLD accessible to the

microprocessor can then be used to monitor and instrument the FPGA's control, data, and status bits. Microprocessors typically have a limited number of control signals, and a simple CPLD design can map a portion of the microprocessor's address space to control FPGA configuration. Using this method, the CPLD establishes a synchronous interface between the microprocessor and the Xilinx FPGA. Such an interface can also allow the microprocessor to do more advanced functions, such as partial reconfiguration and readback.

Configuration Background

Microprocessor programming of Virtex and Spartan FPGA families can be accomplished in either Slave Serial and SelectMAP mode. There are several similarities between Slave Serial and SelectMAP modes. Most importantly, the overall configuration flow is identical for both modes (Figure 2).

Note: Some Spartan FPGA families use the term parallel mode. Parallel mode is equivalent to the SelectMAP mode in function. See the Spartan FPGA data sheets for details. The Spartan/XL FPGAs do not support a parallel mode.

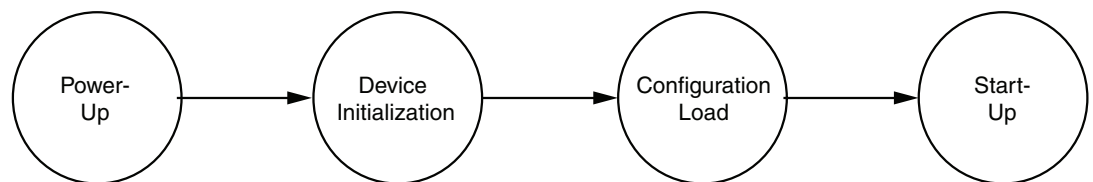

X502_02_111507

Figure 2: Configuration Flow

- **Power-Up**
Power-up is when power is first applied to the FPGA. Internal state machines are reset, and the device begins to wake up. At this point, the PROGRAM and INIT pins are both driven Low by the FPGA.
- **Device Initialization**
The device has properly powered up, but the internal configuration memory needs to be reset. This portion of the configuration flow is signaled by PROGRAM going High and INIT going High a short time later (see the appropriate data sheet for this delay). The device can remain permanently in this state if the user holds either PROGRAM or INIT Low externally.
- **Configuration Load**
The start of the configuration load phase is signaled by the INIT signal going High. After INIT goes High, the mode pins (M2:M0) are sampled (the mode pins indicate which configuration mode is desired). Consult the data sheet for the mode-pin settings required for the mode/device combination. In this phase, the device receives configuration data. All configuration events occur on the rising edge of CCLK.
- **Start-Up**
After the device receives all the configuration data, it proceeds to the start-up sequence. This sequence governs when the global reset signals (GTS, GWE, and for Virtex/Virtex-E/Spartan-II/Spartan-IIE FPGAs, GSR) are toggled, and when the DONE pin goes High. DONE going High does not signal completion of configuration — additional CCLK cycles are needed to complete the start-up sequence. The number of CCLK cycles needed after the delivery of a configuration bitstream depends on the selected BitGen options affecting FPGA start-up (for example, DCM_lock or DCI_match) used for the FPGA bitstream. When start-up extending options are not selected, the bitstream typically contains enough data after the initiation of the start-up sequence to complete the sequence before the end of the bitstream is reached. However, the best practice (to cover all possible bitstream start-up options) is to load all the data from the configuration file, continue to apply CCLK cycles (while the data bits are all ones) until DONE is asserted High, and finally, apply eight additional CCLK cycles after DONE is asserted High to ensure completion of the FPGA start-up sequence. Consult the FPGA family user guide and the BitGen section of the *Development Systems Reference Guide* within the [ISE software manuals](#) for additional BitGen options and details.

Slave-Serial-Specific Topics

After $\overline{\text{INIT}}$ goes High, one bit of Slave Serial configuration data (presented on the DIN pin) is loaded into the configuration logic on each rising CCLK edge (refer to the appropriate data sheet for setup and hold-time specifications). [Table 1](#) describes the pins used during Slave Serial configuration.

Table 1: Slave Serial Pin Descriptions

Signal Name	Direction	Description
CCLK	Input	Configuration clock.
$\overline{\text{PROGRAM}}$	Input/Output	Asynchronous reset to configuration logic. Indicates when the device has cleared configuration memory.
$\overline{\text{INIT}}$	Input/Output	Input to delay configuration. Indicates when the device is ready to receive configuration data; also indicates any configuration errors.
DONE	Input/Output	Input to delay device start-up. Indicates when configuration is in the start-up sequence.
M[2:0]	Input	Configuration mode selection.
DIN	Input	Serial configuration data input.
DOUT	Output	Data output for serial daisy chains.

SelectMAP-Specific Topics

SelectMAP configuration data is loaded one byte at a time when presented on the D[0:7] bus on each rising CCLK edge, with the most significant bit (MSB) of each configuration byte on the D0 pin (see [“Data Formatting and Byte-Swapping,”](#) page 4 for more details). [Table 2](#) lists the SelectMAP pins.

Two extra control signals are present for SelectMAP: $\overline{\text{CS}}$ and $\overline{\text{WRITE}}$. These signals must both be asserted Low for a configuration byte to be transferred to the FPGA. A third signal, BUSY, is an output from the FPGA. When SelectMAP configuration is run quickly (for example, greater than 50 MHz for Virtex families), the BUSY line must be monitored to ensure that data is transferred. BUSY going High indicates that the last data byte was not transferred and must remain on the data bus.

Note: Check the appropriate FPGA family data sheet for the existence of a BUSY pin and the CCLK frequency above which the BUSY pin becomes active. Also, refer to the appropriate data sheet for setup-and-hold specifications for all signals.

Table 2: SelectMAP Pin Descriptions

Signal Name	Direction	Description
CCLK	Input	Configuration clock.
$\overline{\text{PROGRAM}}$	Input/Output	Asynchronous reset to configuration logic. Indicates when the device has cleared configuration memory.
$\overline{\text{INIT}}$	Input/Output	Input to delay configuration. Indicates when the device is ready to receive configuration data; also indicates any configuration errors.
DONE	Input/Output	Input to delay device start-up. Indicates when configuration is in the startup sequence.
M[2:0]	Input	Configuration mode selection.
D[0:7]	Input	Byte-wide configuration data input.
$\overline{\text{CS}}$	Input	Active-Low chip-select input.
$\overline{\text{WRITE}}$ (or RDWR_B)	Input	Active-Low write select/read select.
BUSY	Output	Handshaking signal to indicate successful data transfer (same pin as DOUT in Serial mode).

Data Formatting and Byte-Swapping

Because the configuration bitstream is loaded into memory connected to the processor, it must be formatted in a way that the processor (or whatever device programs the memory) can use. To support various solutions, Xilinx tools can produce a number of different formats (Table 3).

Table 3: Xilinx Tool Formats

File Extension	Description
.bit	Binary file containing header information that should <i>not</i> be downloaded to the FPGA.
.rbt	ASCII file containing a text header and ASCII 1's and 0's.
.bin	Binary file containing no header information (only produced by 4.1i and later versions of Xilinx software).
.mcs, .exo, .tek	ASCII PROM formats containing address as well as checksum information.
.hex	ASCII PROM format only containing data.

Generally, either the .bin or .hex files are the most useful data source for programming non-volatile memory. A Perl script (bitformat.pl) is included with this application note should additional formatting be required. This script uses the .bit or .rbt file as a source and produces a user-customizable ASCII file that can be helpful in programming the on-board memory. Xilinx implementation software must be installed on the machine running this Perl script because the PROMGen program is called from within the script (for details, see the bitformat.readme file included).

In terms of data ordering, Slave Serial configuration is very simple. Loading begins with the first bit in the bitstream and continues one bit at a time until the end of the file is reached.

In contrast, data ordering for SelectMAP configuration is slightly more complex. Configuration data is loaded one byte at each rising CCLK edge, and the MSB of each byte is presented on the D0 pin, not the D7 pin. Because of this non-conventional ordering, presenting the data as is from the .bin file is generally incorrect. The reason is that most processors interpret D7 (not D0) as the most significant bit in each byte. Connecting D7 on the processor to the D7 on the FPGA SelectMAP data bus effectively loads the data backwards, resulting in unsuccessful configuration. For this reason, the source data stream might need to be byte-swapped, with bits in each byte in the data stream reversed. Figure 3 shows two bytes (0xABCD) being reversed.

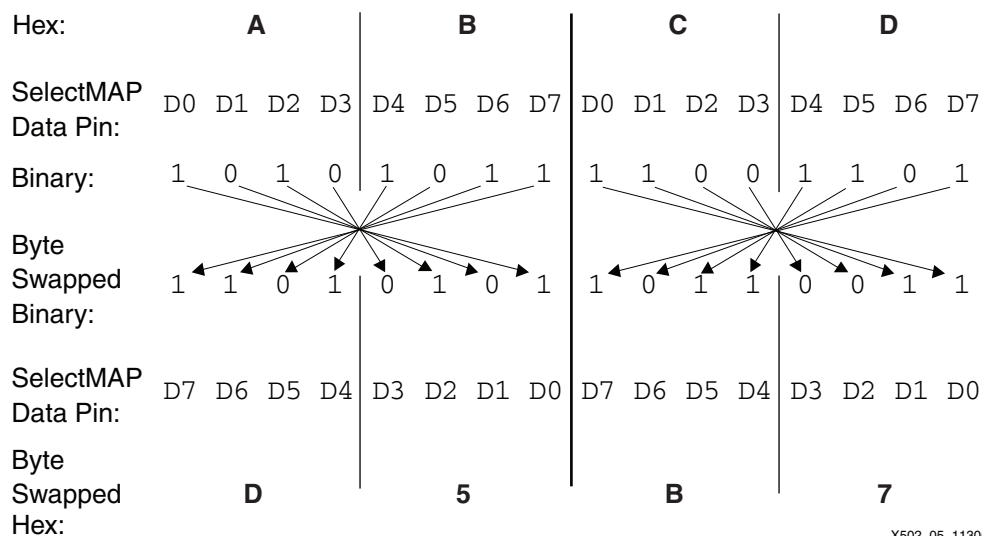

Figure 3: Byte-Swapping Example

Regardless of the orientation of the data, the MSB of each byte of the data must be transmitted to D0. However, in the byte-swapped version of the data, the bit that must be transmitted to D0 is the rightmost bit and, in the non-byte-swapped data, the leftmost bit. The Perl script included in this application note can be customized to produce byte-swapped files or not, as needed (see the `bitformat.readme` file for details). With Xilinx software, the `.mcs`, `.exo`, and `.tek` files are always byte-swapped, and the `.bit`, `.rbt`, and `.bin` files are never byte-swapped. Hex files can be produced byte-swapped according to command-line options.

Note: Whether or not data is byte-swapped is entirely processor/application dependent and is generally only applicable for SelectMAP applications. Non-byte-swapped data should be used for Slave Serial downloads.

Errors and Troubleshooting

If configuration is not successful, the DONE pin does not go High after all the data is loaded. There are many different reasons why this situation can occur. Possible causes can be discovered by searching the Xilinx Answers Database or using the Configuration Problem Solver at: <http://support.xilinx.com>.

Hardware Implementation

Microprocessor

The application reference design is based on a Motorola Dragonball MC68VZ328 processor. This specific design uses a Handspring Visor handheld computer to configure a Xilinx Virtex FPGA. To complete the system, an Insight Springboard Development Kit provides 32 Mb of on-board flash memory, as well as a 256-macrocell CoolRunner™ CPLD.

Figure 4 shows the memory map for the Dragonball processor used in this design. The Handspring Visor Springboard expansion slot provides two chip select regions available to the user, called Chip Select 0 and Chip Select 1. The flash memory is connected to the Chip Select 0 region, defined as the address space between `0x28000000` and `0x28FFFFFF`. The CPLD is connected to the Chip Select 1 region, defined by the address space between `0x29000000` and `0x29FFFFFF`. Each address location references eight bits of data. However, the Dragonball processor does not support byte-wide addressing. As a consequence, the microprocessor's address line 0 is not used. Therefore, data can only be accessed on even address locations (in other words, `0x28000000`, `0x28000002`, etc.). Each access reads or writes 16 bits of data. Accessing address locations on odd boundaries is not allowed.

The shaded area on the bottom of the memory map shown in Figure 4 represents portions of memory used specifically by the processor for internal functions. This memory space is not utilized in this reference design.

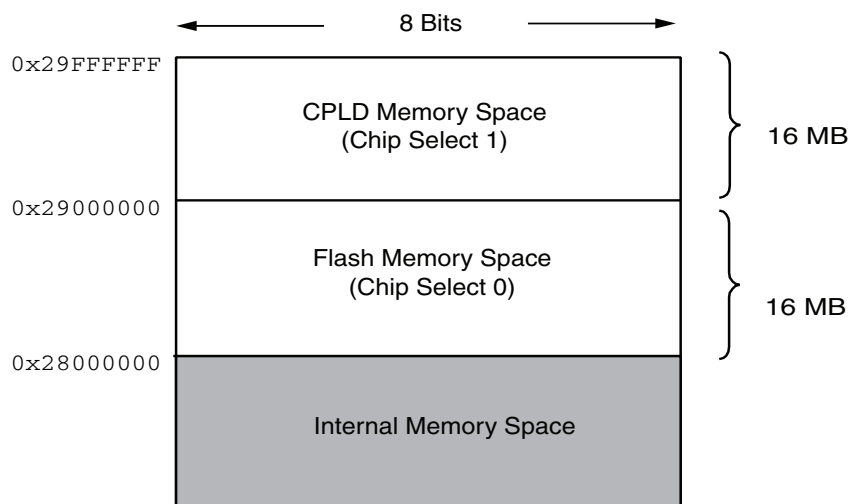

X502_06_111507

Figure 4: Microprocessor Memory Map

Note: Even though a Motorola Dragonball processor is used in this reference design, any microprocessor can be used. In addition, the microprocessor code in this reference design can be easily ported to different processors. However, remapping requires an understanding of how to retarget the memory-mapped Dragonball I/O structure to match the memory map of another processor.

Flash Memory

In this design, the 16-bit wide flash memory begins at address $0x28000000$ and ends at address $0x28FFFFFF$. As shown in Figure 5, a Virtex XCV50 configuration bitstream consists of 559,200 bits. Because each address location contains 16 bits of data, a total of 34,950 addresses are needed. The first 16 bits of configuration data reside at address $0x28000200$ and the final 16 bits are located at address $0x2801130A$. This design arbitrarily chose address $0x28000200$ to be the starting address in order to simulate actual customer scenarios in which flash memory is also used to hold other system data.

The data within the flash memory might need to be byte-swapped, depending upon the application. For this design, byte-swapped data is used for SelectMAP configuration but not for Slave-Serial configuration. Byte-swapping reformats the FPGA configuration data so that the order of the bits within each byte is reversed. For a complete description of byte-swapping, refer to the description in “Configuration Background,” page 2.

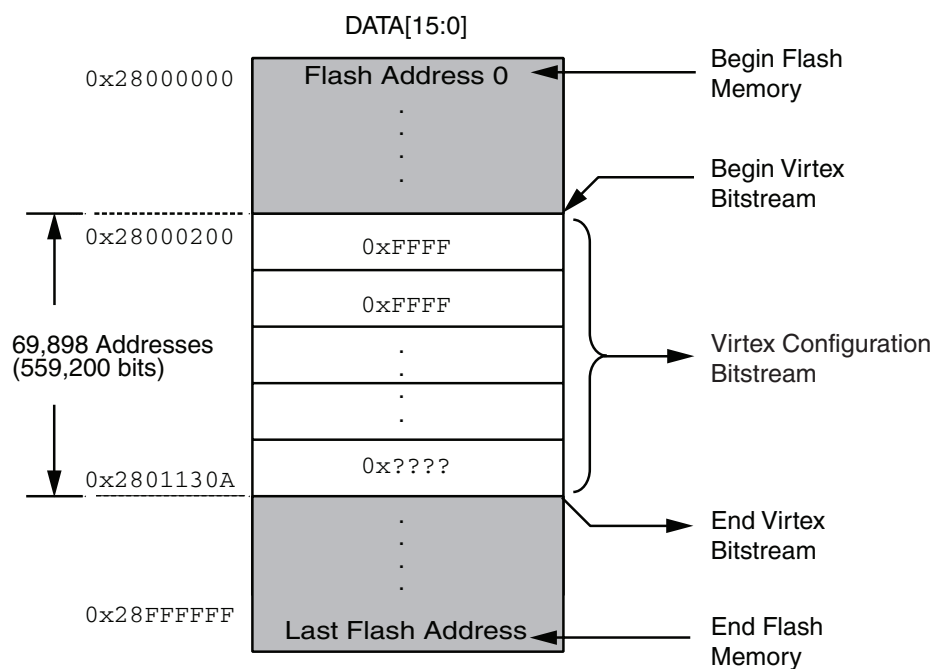

Figure 5: Flash Memory Map

X502_07_111507

SelectMAP Hardware

This section discusses a reference design allowing a microprocessor to configure an FPGA device via the SelectMAP mode (SelectMAP configuration mode is the fastest configuration option). In order to accomplish SelectMAP configuration, this design uses a combination of a microprocessor, CPLD, and flash memory (Figure 6).

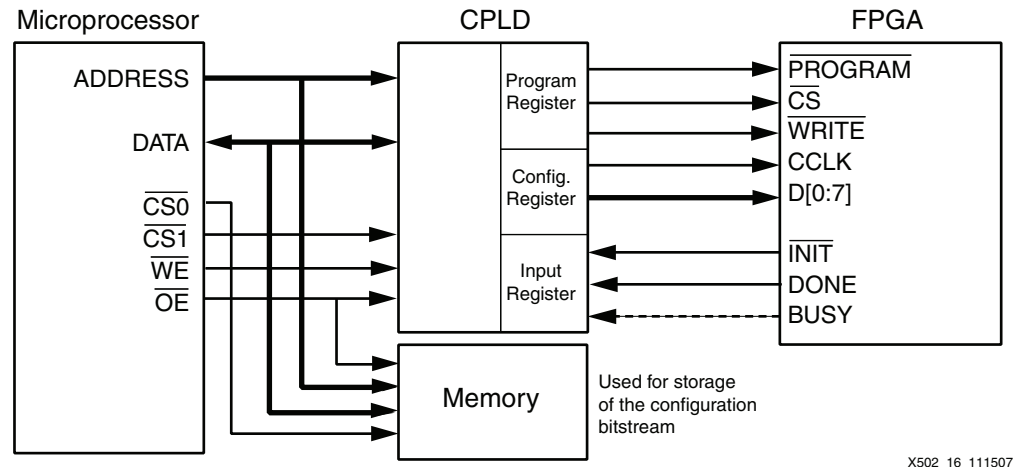

Figure 6: SelectMAP Configuration

A 16-bit wide flash memory device is used to store the FPGA configuration data. Because each flash address stores 16-bits of data, the microprocessor reads each address to retrieve the 16-bit wide data and delivers the data in a byte-wide fashion to the FPGA. During this process, the microprocessor provides the FPGA with a configuration clock and monitors the DONE and BUSY pins. A CPLD is used to form the glue logic between the microprocessor and the FPGA device.

CoolRunner CPLD

A Xilinx CoolRunner CPLD is used for glue logic between the microprocessor and the Xilinx Virtex FPGA. In the SelectMAP configuration mode, the CoolRunner device is responsible for driving the Virtex FPGA configuration pins, namely PROGRAM, CS, WRITE, CCLK, and D[0:7]. The Virtex FPGA's INIT, DONE, and BUSY pins are also registered by the CPLD, allowing the status of these pins to be monitored by the microprocessor.

The CoolRunner CPLD is used to establish a synchronous interface between the microprocessor and the Xilinx FPGA. This interface is comprised of three registers: the Configuration Register, Program Register, and Input Register. These registers store FPGA configuration signals each time the processor does a read or write to the port, supporting the set of signals required for SelectMAP mode (PROGRAM, CCLK, DATA[0:7], INIT, CS, WRITE, DONE, and BUSY). The Configuration Register and Program Register are write-only registers, while the Input Register is read-only.

A detailed block diagram of the CPLD is shown in [Figure 7](#).

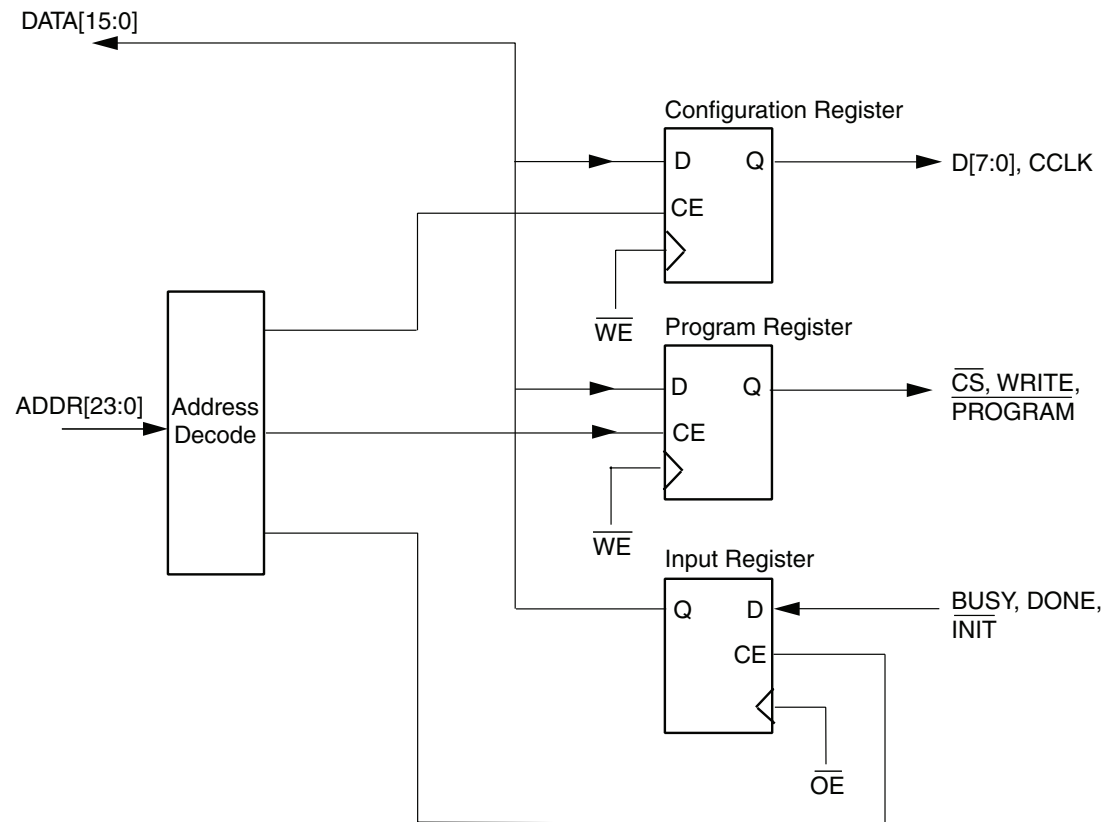

X502_09_111507

Figure 7: CPLD Block Diagram

The register address map is shown in [Table 4](#).

Table 4: Register Address Map

Register Address A[23:0]	Register Name	Register Data										
		D[15:9]	D8	D7	D6	D5	D4	D3	D2	D1	D0	
0x000000	Configuration Register	D[7:0]	–	–	–	–	–	–	–	–	–	CCLK
0x000002	Program Register	–	–	–	–	–	–	–	CS	WRITE	PROGRAM	
0x000004	Input Register	–	–	–	–	–	–	–	BUSY	DONE	INIT	

SelectMAP.c

The C code discussed in this section allows a microprocessor to:

- Read FPGA configuration data from flash memory
- Generate a CCLK
- Deliver byte-wide data to the FPGA
- Check the status of the BUSY pin (optional)

Note: Different microprocessors have different memory-mapped I/O structures, depending upon the system configuration. Therefore, while the majority of the C code listed here should be easily transportable, the user must modify the sections of code that command the microprocessor to perform a write operation on its data bus to match the memory map of the new microprocessor.

To allow for maximum readability, all C code shown in this reference design accesses the microprocessor address and data bus uniformly using two functions: `IOWrite()` and `IORead()`. `IOWrite()` writes a 16-bit word to a specified address location; `IORead()` retrieves a 16-bit result from a specified location. Refer to “[Microprocessor](#),” page 5 for this reference design’s memory map and to “[Appendix: Processor Specific I/O Function Calls](#),” page 14 for the syntax of the `IOWrite()` and `IORead()` functions.

The `SelectMAP.c` source file contains three important functions: `SelectMAP()`, `SelectMAP_output()`, and `Busy_Check()`. The `SelectMAP()` function is called from within the `main` function to begin configuration. `SelectMAP()` pulses the FPGA’s `PROGRAM` pin and checks for `INIT` deassertion. After `INIT` is deasserted, the FPGA is ready to receive configuration data, and the `SelectMAP_output()` function is called. A software flow diagram is shown in [Figure 8, page 10](#).

First, the processor writes to the Program Register to assert the `PROGRAM` pin, resetting the FPGA.

Note: A loop might be required to assert the FPGA’s `PROGRAM` pin for the minimum required time (refer to the appropriate data sheet). If the FPGA just completed power-up or is reset through other means, this loop is not necessary.

After the `PROGRAM` bit is asserted, the `SelectMAP()` function checks the CPLD Input Register until `INIT` is High. Then, the function enters a **for** loop that cycles through the flash memory address range containing the FPGA configuration data. In this example, using a XCV50 device, the address range is between `0x28000200` and `0x2801130A`. For each address location, 16-bit data is retrieved, and the `SelectMAP_output()` function is called to perform presentation of byte-wide data to the FPGA.

Note: In the `SelectMAP_output()` function, two write cycles are needed for each byte in the configuration file. One cycle is needed for driving `CCLK` Low and to present the next configuration byte. A second cycle is needed to drive `CCLK` High. Immediately after driving the `CCLK` pin High, `Busy_Check()` is called to ensure that the data is properly received by the FPGA.

If `BUSY` is asserted (High), the `Busy_Check()` function continues to provide additional `CCLK` cycles until `BUSY` is deasserted. Monitoring the FPGA Busy pin via this function is optional.

Note: The maximum speed of `SelectMAP` configuration varies for different FPGA families. Check the appropriate data sheet for this specification.

After all configuration data is loaded, the **for** loop is terminated, and the `SelectMAP()` function checks the CPLD Input Register for `DONE` assertion.

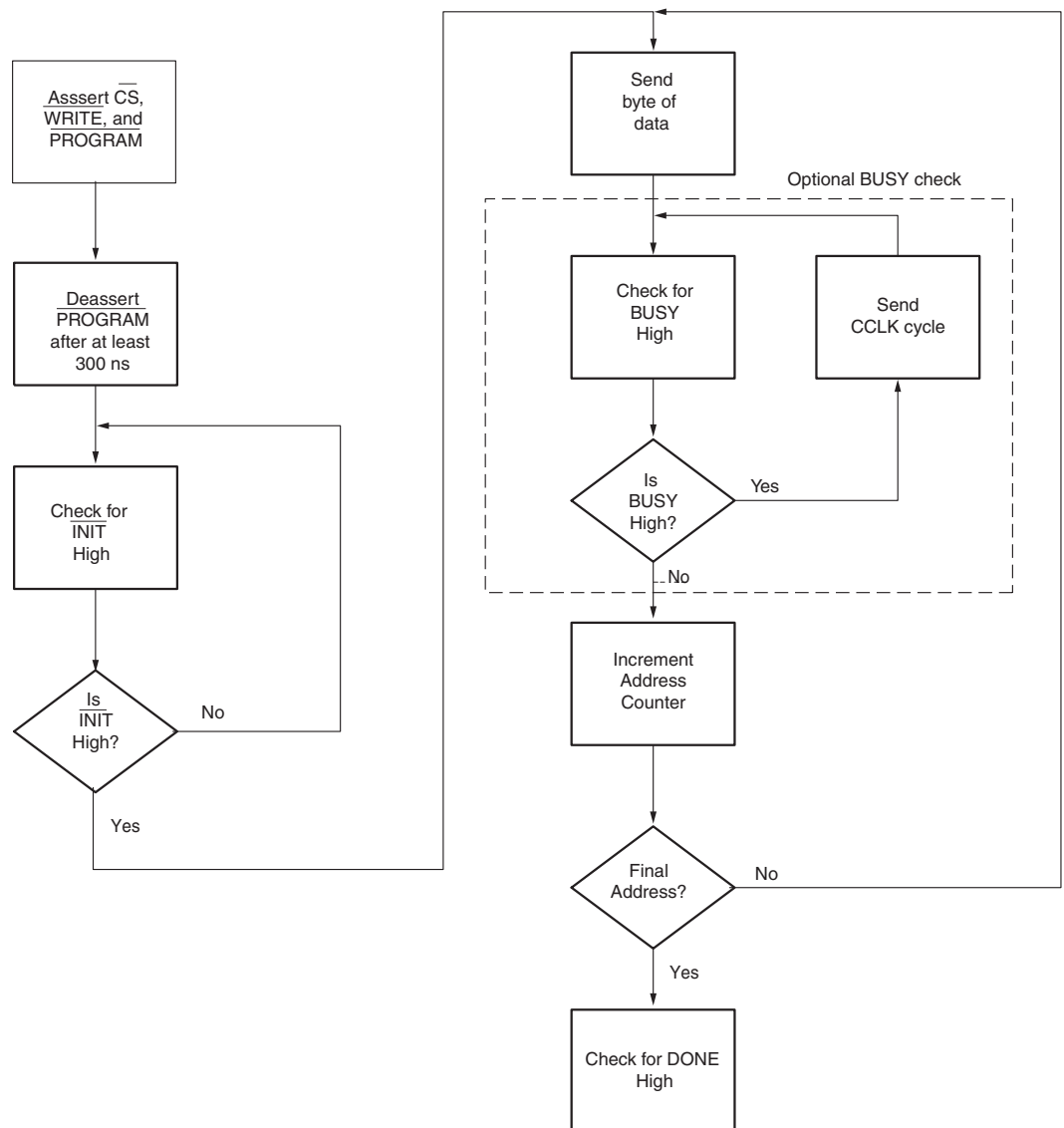

x502_04_103101

Figure 8: Select MAP Configuration Flow Diagram

Slave Serial Hardware

This section discusses a reference design allowing a Virtex FPGA to be configured in the Slave Serial mode through a combination of a microprocessor and a CPLD. Slave Serial configuration is accomplished by providing a Virtex FPGA with a serial clock and delivering a single data bit at every rising edge of the clock until the final configuration bit is sent.

The design shown in [Figure 9, page 11](#) uses a 16-bit flash memory to store the FPGA configuration data. Because each flash address stores 16-bits of data, the microprocessor reads each address, retrieves the 16-bit data, and serializes the data. This process continues until the final 16 bits of configuration data is read and serialized. During this process, the microprocessor is also responsible for providing the FPGA with a configuration clock. A CPLD is used to decode both the serialized bitstream, as well as the configuration clock, and is ultimately responsible for toggling the Virtex FPGA's configuration pins.

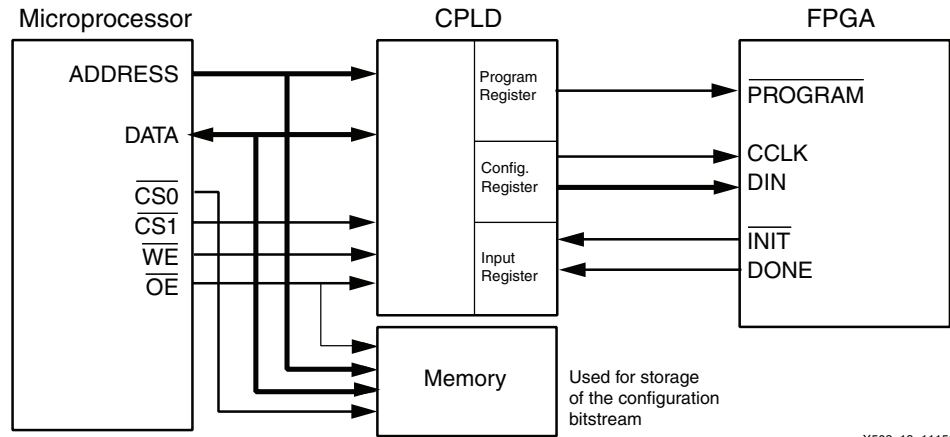

X502_18_111507

Figure 9: Slave Serial Configuration

CoolRunner CPLD

A Xilinx CoolRunner CPLD is used for glue logic between the microprocessor and the Xilinx Virtex FPGA. In the Slave Serial mode of configuration, the CoolRunner device is responsible for driving the Virtex FPGA configuration pins, namely PROGRAM, CCLK, and DIN. The Virtex device's INIT and DONE pins are also registered by the CPLD, allowing the status of these pins can be read by the microprocessor.

The CoolRunner CPLD is used to establish a synchronous interface between the microprocessor and the Xilinx FPGA. The interface is comprised of three registers: the Configuration Register, Program Register, and Input Register. These registers store FPGA configuration signals each time the processor does a read or write to the port, supporting the set of signals required for Slave Serial mode (PROGRAM, DIN, CCLK, INIT and DONE). The Configuration Register and Program Register are write-only registers, while the Input Register is read-only. A detailed block diagram of the CPLD design is shown in Figure 10. The Register Address Map is shown in Table 5, page 12.

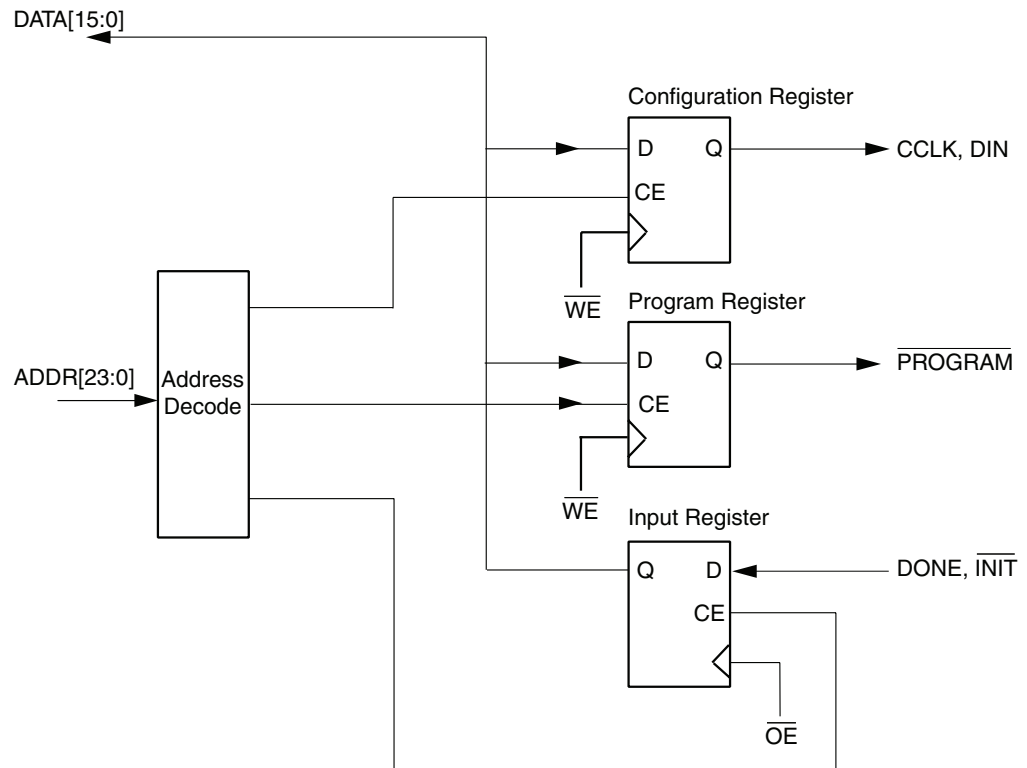

X502_17_111507

Figure 10: CPLD Block Diagram

Table 5: Register Address Map

Register Address A[23:0]	Register Name	Register Data							
		D7	D6	D5	D4	D3	D2	D1	D0
0x000000	Configuration Register	–	–	–	–	–	–	CCLK	DATA
0x000002	Program Register	–	–	–	–	–	–	–	PROGRAM
0x000004	Input Register	–	–	–	–	–	–	DONE	INIT

SlaveSerial.c

The C code discussed in this section allows a microprocessor to:

- Read FPGA configuration data from flash memory
- Provide a CCLK
- Serialize the configuration bitstream

Note: Different microprocessors have different memory-mapped I/O structures, depending upon the system configuration. Therefore, while the majority of the C code listed here should be easily transportable, the user must modify the sections of code that command the microprocessor to perform a write operation on its data bus to match the memory map of the new microprocessor.

To allow for maximum readability, all C code shown in this reference design accesses the microprocessor address and data bus uniformly using two functions: IOWrite() and IORead(). IOWrite() writes a 16-bit word to a specified address location; IORead() retrieves a 16-bit result from a specified location. Refer to “Microprocessor” for this reference design’s memory map and to “Appendix: Processor Specific I/O Function Calls” for the syntax of these two functions.

Within the SlaveSerial.c source file, two functions, SlaveSerial() and ShiftDataOut() accomplish configuration. To begin configuration, SlaveSerial() is called from within the main() function and is responsible for pulsing the program pin, checking for INIT deassertion, then calling the ShiftDataOut() function. A software flow diagram is shown in Figure 11.

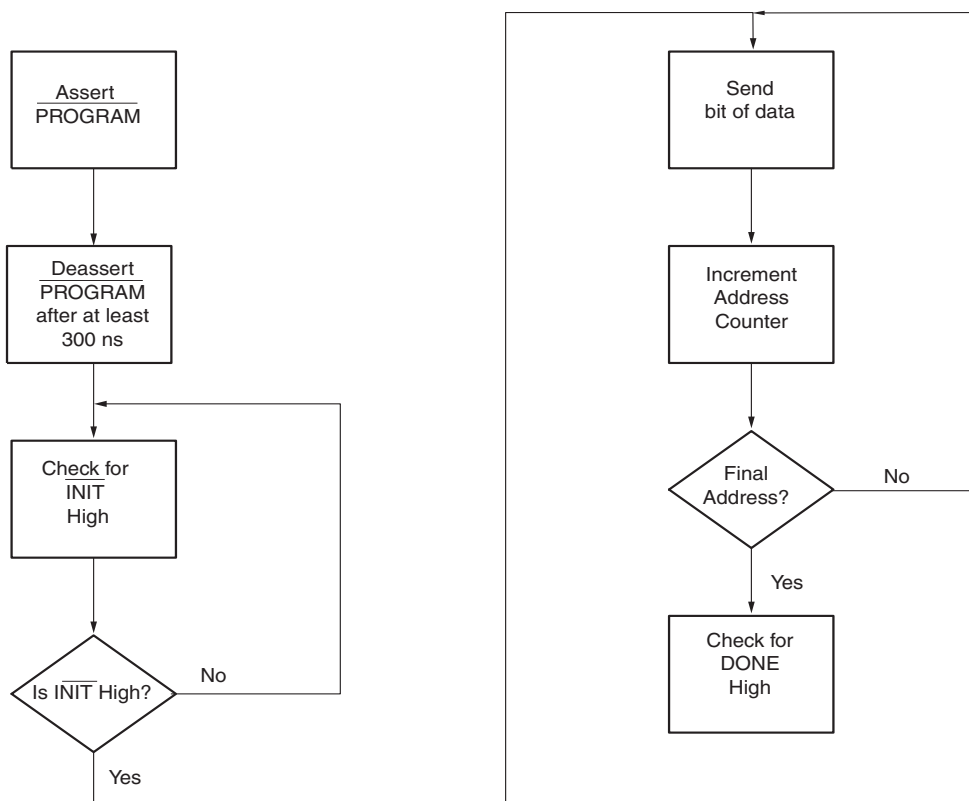

x502_03_103101

Figure 11: Slave Serial Configuration Flow Diagram

First, the processor writes to the Program Register to assert the $\overline{\text{PROGRAM}}$ pin, resetting the FPGA.

Note: A loop might be required to assert the FPGA's $\overline{\text{PROGRAM}}$ pin for the minimum required time (refer to the appropriate data sheet). If the FPGA just completed power-up or is reset through other means, this loop is not necessary.

After the $\overline{\text{PROGRAM}}$ bit is asserted, the SlaveSerial() function checks the CPLD Input Register until $\overline{\text{INIT}}$ is High. Then, the function enters a **for** loop that cycles through the flash memory address range containing the FPGA configuration data. In this example, using a XCV50 device, the flash address range is between 0x28000200 and 0x2801130A. For each address location, the 16-bit data is retrieved, and the ShiftDataOut() function is called to perform serialization and presentation of the data to the FPGA.

Note: The ShiftDataOut() function, two write cycles are needed each bit in the configuration file. One cycle is needed for driving CCLK Low and to present the next configuration bit. A second cycle is needed to drive CCLK High. After all configuration data is loaded, the **for** loop is terminated, and the SlaveSerial() function checks the CPLD Input Register for DONE assertion.

Reference Design Files

The latest version of this application note and reference design files can be downloaded from the Xilinx website at:

<https://secure.xilinx.com/webreg/clickthrough.do?cid=98848>

Conclusion

This application note provides a background on configuration as well as a description of two complete sets of reference designs allowing a Xilinx FPGA device to be configured through SelectMAP or Slave Serial mode. While the microprocessor C code targets a Motorola 68VZ328 Dragonball processor, it was written with portability in mind. Porting the code to another processor requires some effort, but all the design files are documented extensively. Also, complete design files for a Xilinx CPLD design are included to provide a synchronous interface between the microprocessor and the target Xilinx FPGA.

Appendix: Processor Specific I/O Function Calls

IOWrite(int Addr, int Data)

To use IOWrite(), an address and data must be passed to the function. In this reference design, the Configuration, Program, and Input Registers are located at 0x29000000, 0x29000002, and 0x29000004, respectively. These are the only three address values ever written to.

I/O Write Usage Example

Table 6: I/O Write Usage Example

IOWrite(0x29000000, 0x0011)	Write to CPLD Configuration Register: "1" = CCLK "1" = DATA
IOWrite(0x29000000, 0x0001)	Write to CPLD Configuration Register: "0" = CCLK "1" = DATA
IOWrite(0x29000002, 0x0001)	Write to CPLD Program Register: "1" = Program

The timing diagram for a microprocessor write cycle is shown below in [Figure 12](#).

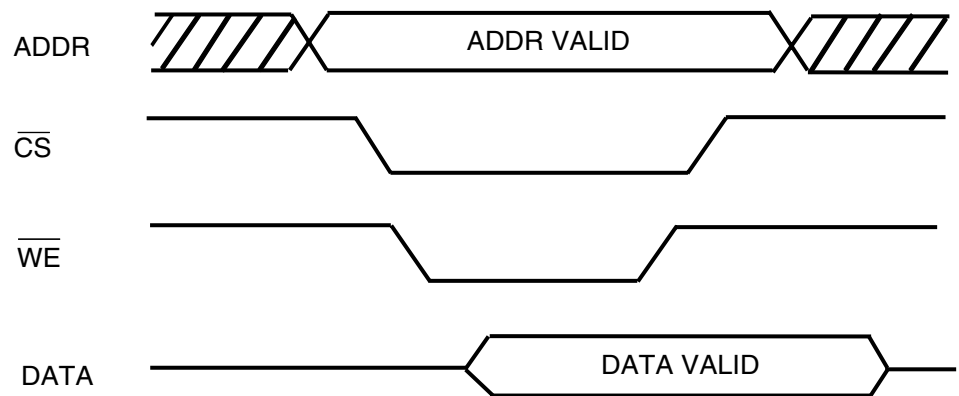

x502_15_103101

Figure 12: Write-Cycle Timing Diagram

IOWrite(int Addr)

To use IOWrite(), an address must be provided. The 16-bit data value at that address is then returned. In this design, data is read from address ranges between 0x28000200 and 0x2801130A, as well as address location 0x29000004. The former is where the FPGA Configuration bitstream is stored, and the latter is the location of the Input Register.

I/O Read Usage Example

Table 7: I/O Read Usage Example

IOWrite(0x28000200)	Retrieve the first 16 bits of configuration data from flash memory.
IOWrite(0x28000201)	Retrieve the second 16 bits of configuration data from flash memory.
IOWrite(0x2801130A)	Retrieve the final 16-bits of configuration data from flash memory.
IOWrite(0x29000004)	Read from Input Register to determine values of DONE and INIT.

The timing diagram for a microprocessor read cycle is shown below in [Figure 13](#).

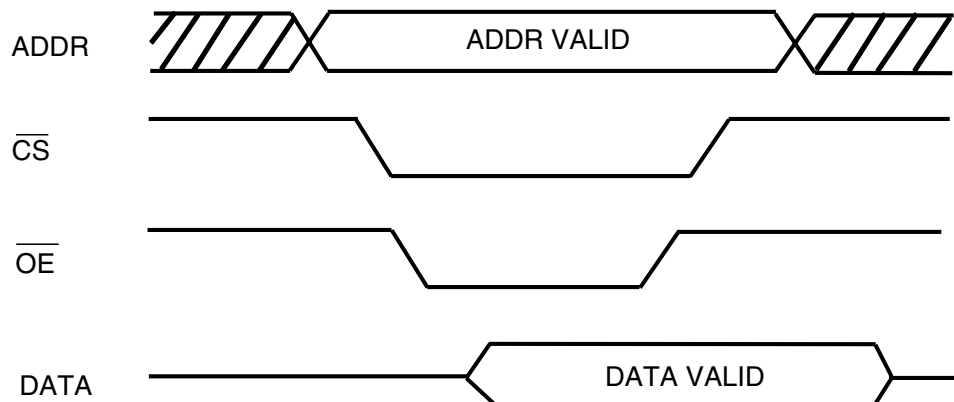

x502_19_103101

Figure 13: Read-Cycle Timing Diagram

Revision History

The following table shows the revision history for this document.

Date	Version	Revision
12/03/01	1.0	Initial Xilinx release.
01/08/02	1.1	Added Spartan-IIE to "Summary," page 1 .
06/10/02	1.2	Added "Virtex Series, Virtex-II Series Platform FPGAs, and Spartan-II Series" to "Summary," page 1 .
11/06/02	1.3	Updated Figure 5, page 6 and Figure 7, page 8 .
11/13/02	1.4	Updated Figure 10, page 11 .
12/03/07	1.5	<ul style="list-style-type: none"> • Updated document template. • Update URLs. • Updated list of applicable FPGA families. • Updated BUSY activation frequency in "SelectMAP-Specific Topics," page 3. • Enhanced start-up CCLK requirements in "Configuration Background," page 2. • Completed other edits and corrections.

Notice of Disclaimer

Xilinx is disclosing this Application Note to you "AS-IS" with no warranty of any kind. This Application Note is one possible implementation of this feature, application, or standard, and is subject to change without further notice from Xilinx. You are responsible for obtaining any rights you may require in connection with your use or implementation of this Application Note. XILINX MAKES NO REPRESENTATIONS OR WARRANTIES, WHETHER EXPRESS OR IMPLIED, STATUTORY OR OTHERWISE, INCLUDING, WITHOUT LIMITATION, IMPLIED WARRANTIES OF MERCHANTABILITY, NONINFRINGEMENT, OR FITNESS FOR A PARTICULAR PURPOSE. IN NO EVENT WILL XILINX BE LIABLE FOR ANY LOSS OF DATA, LOST PROFITS, OR FOR ANY SPECIAL, INCIDENTAL, CONSEQUENTIAL, OR INDIRECT DAMAGES ARISING FROM YOUR USE OF THIS APPLICATION NOTE.