

HW-AMS-101 REV 1.0

DISCLAIMER:

XILINX IS DISCLOSING THIS USER GUIDE, MANUAL, RELEASE NOTE, SCHEMATIC, AND/OR SPECIFICATION (THE "DOCUMENTATION") TO YOU SOLELY FOR USE IN THE DEVELOPMENT OF DESIGNS TO OPERATE WITH XILINX HARDWARE DEVICES. YOU MAY NOT REPRODUCE, DISTRIBUTE, REPUBLISH, DOWNLOAD, DISPLAY, POST, OR TRANSMIT THE DOCUMENTATION IN ANY FORM OR BY ANY MEANS INCLUDING, BUT NOT LIMITED TO, ELECTRONIC, MECHANICAL, PHOTOCOPYING, RECORDING, OR OTHERWISE, WITHOUT THE PRIOR WRITTEN CONSENT OF XILINX.

XILINX EXPRESSLY DISCLAIMS ANY LIABILITY ARISING OUT OF YOUR USE OF THE DOCUMENTATION. XILINX RESERVES THE RIGHT, AT ITS SOLE DISCRETION, TO CHANGE THE DOCUMENTATION WITHOUT NOTICE AT ANY TIME. XILINX ASSUMES NO OBLIGATION TO CORRECT ANY ERRORS CONTAINED IN THE DOCUMENTATION, OR TO ADVISE YOU OF ANY CORRECTIONS OR UPDATES. XILINX EXPRESSLY DISCLAIMS ANY LIABILITY IN CONNECTION WITH TECHNICAL SUPPORT OR ASSISTANCE THAT MAY BE PROVIDED TO YOU IN CONNECTION WITH THE DOCUMENTATION.

THE DOCUMENTATION IS DISCLOSED TO YOU "AS-IS" WITH NO WARRANTY OF ANY KIND. XILINX MAKES NO OTHER WARRANTIES, WHETHER EXPRESS, IMPLIED, OR STATUTORY, REGARDING THE DOCUMENTATION, INCLUDING ANY WARRANTIES OF MERCHANTABILITY, FITNESS FOR A PARTICULAR PURPOSE, OR NONINFRINGEMENT OF THIRD-PARTY RIGHTS. IN NO EVENT WILL XILINX BE LIABLE FOR ANY CONSEQUENTIAL, INDIRECT, EXEMPLARY, SPECIAL, OR INCIDENTAL DAMAGES, INCLUDING ANY LOSS OF DATA OR LOST PROFITS, ARISING FROM YOUR USE OF THE DOCUMENTATION.



ASSY P/N: 0431749
PCB P/N: 1280670
SCH P/N: 0381503

Title: SCHEM, ROHS COMPLIANT
HW-AMS-101 BOARD
TITLE AND DISCLAIMER

Date:	4-18-2012_13:34	Ver:	1.0
Sheet Size:	B	Rev:	01
Sheet	1 of 4	Drawn By	DN

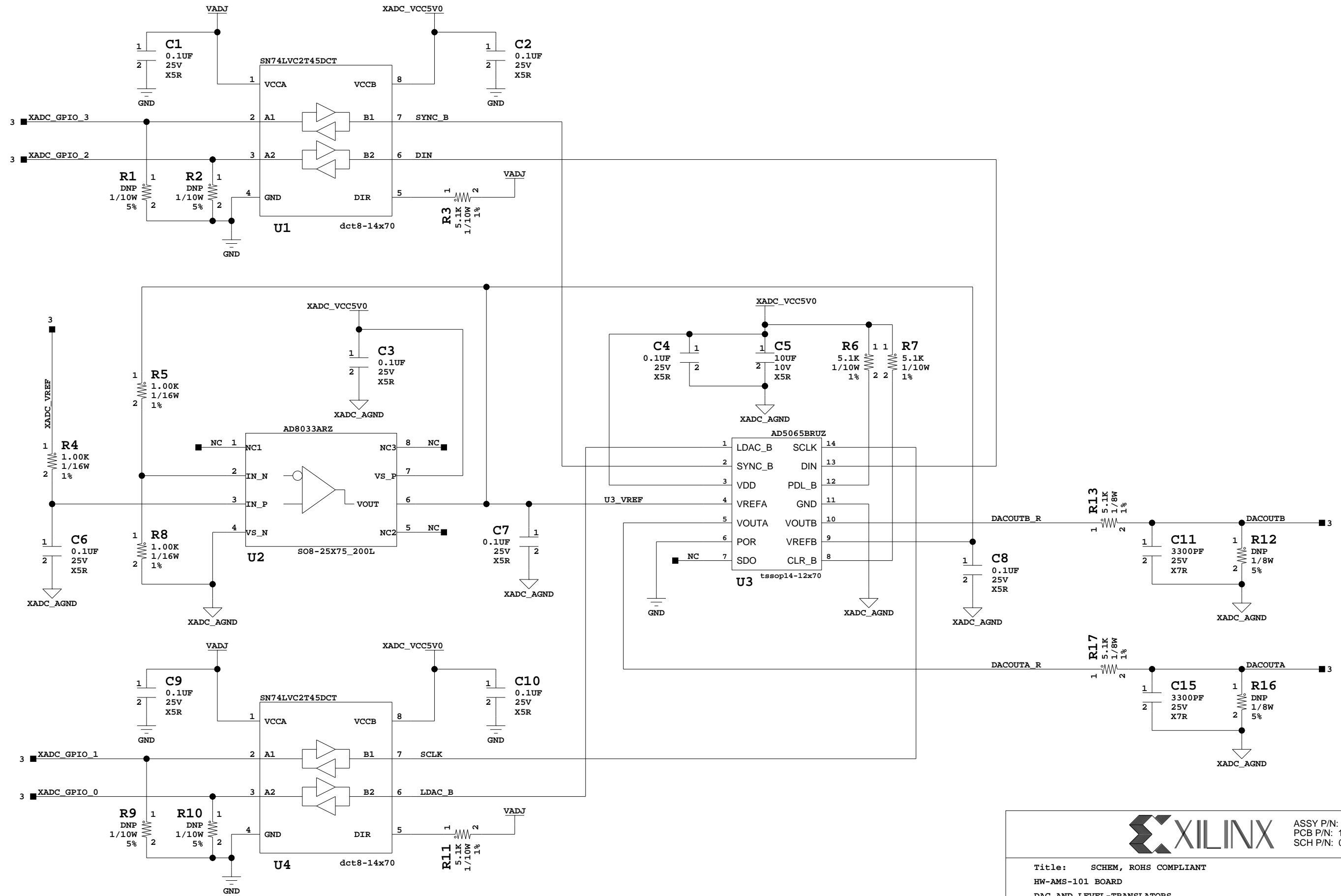

ASSY P/N: 0431749
 PCB P/N: 1280670
 SCH P/N: 0381503

Title: SCHEM, ROHS COMPLIANT
 HW-AMS-101 BOARD
 DAC AND LEVEL-TRANSLATORS

Date:	4-18-2012_13:34	Ver:	1.0
Sheet Size:	B	Rev:	01
Sheet	2 of 4	Drawn By	DN

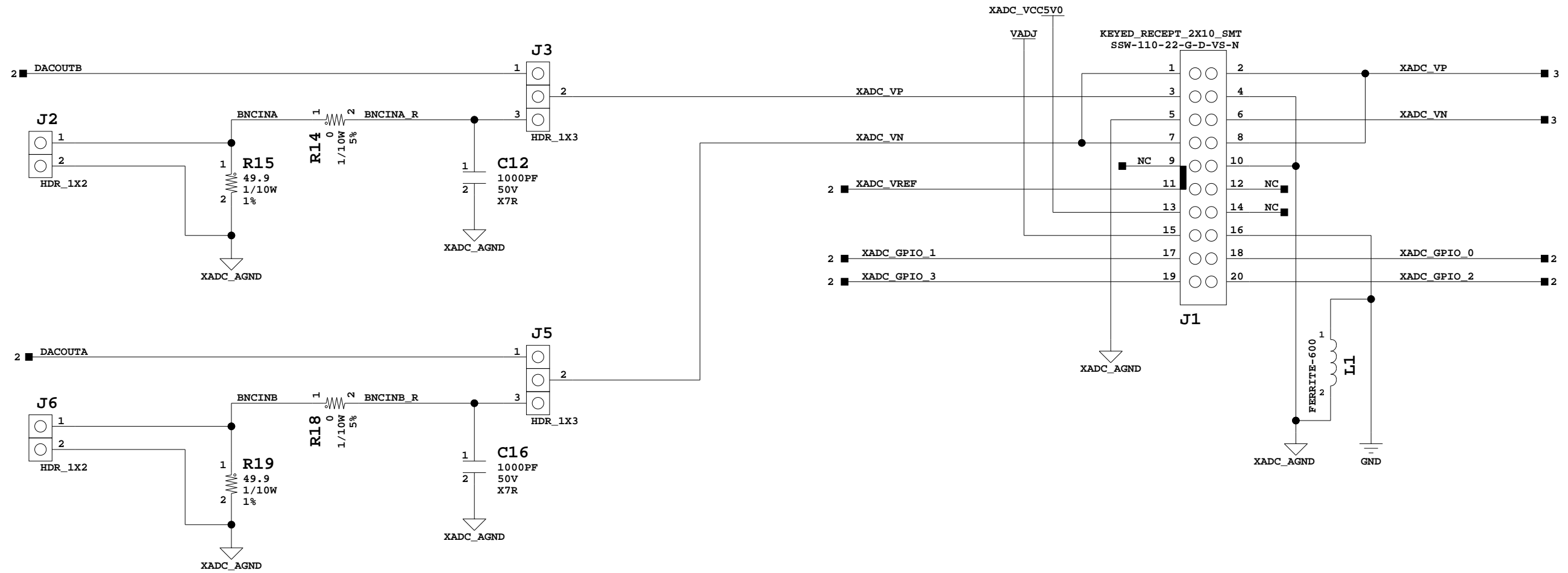

ASSY P/N: 0431749
 PCB P/N: 1280670
 SCH P/N: 0381503

Title: SCHEM, ROHS COMPLIANT
 HW-AMS-101 BOARD
 CARRIER BOARD INTERFACE

Date: 4-18-2012_13:34 Ver: 1.0

Sheet Size: B Rev: 01

Sheet 3 of 4 Drawn By DN

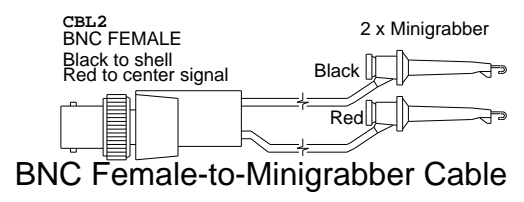
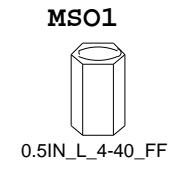
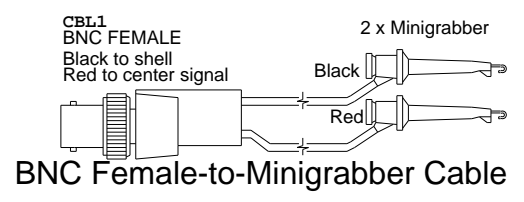
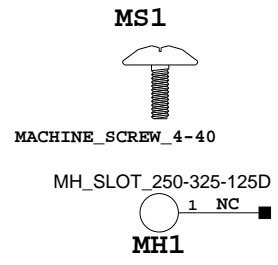

SINGLE PIN GND TEST POINTS

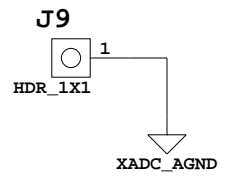
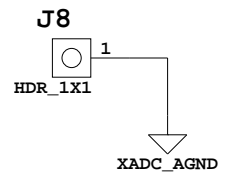
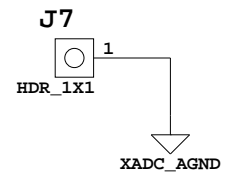
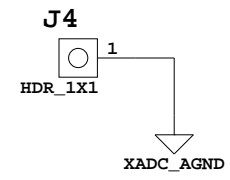

FIDUCIALS

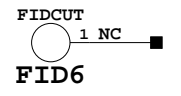
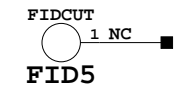
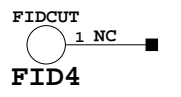
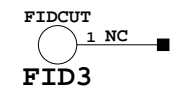
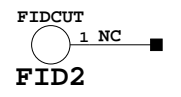
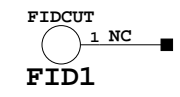

2-PIN JUMPER BLOCKS

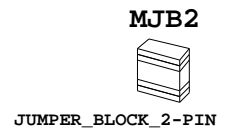
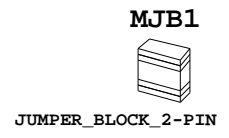

ASSY P/N: 0431749
PCB P/N: 1280670
SCH P/N: 0381503

Title: SCHEM, ROHS COMPLIANT
HW-AMS-101 BOARD
MECHANICALS

Date: 4-18-2012_13:34 Ver: 1.0

Sheet Size: B Rev: 01

Sheet **4** of **4** Drawn By DN