

# Getting Started with XtremeDSP™ Solution Video Starter Kit

*Spartan-3A DSP™ FPGA Edition*

UG455 (v2.0) November 17, 2008





Xilinx is disclosing this user guide, manual, release note, and/or specification (the “Documentation”) to you solely for use in the development of designs to operate with Xilinx hardware devices. You may not reproduce, distribute, republish, download, display, post, or transmit the Documentation in any form or by any means including, but not limited to, electronic, mechanical, photocopying, recording, or otherwise, without the prior written consent of Xilinx. Xilinx expressly disclaims any liability arising out of your use of the Documentation. Xilinx reserves the right, at its sole discretion, to change the Documentation without notice at any time. Xilinx assumes no obligation to correct any errors contained in the Documentation, or to advise you of any corrections or updates. Xilinx expressly disclaims any liability in connection with technical support or assistance that may be provided to you in connection with the Information.

THE DOCUMENTATION IS DISCLOSED TO YOU “AS-IS” WITH NO WARRANTY OF ANY KIND. XILINX MAKES NO OTHER WARRANTIES, WHETHER EXPRESS, IMPLIED, OR STATUTORY, REGARDING THE DOCUMENTATION, INCLUDING ANY WARRANTIES OF MERCHANTABILITY, FITNESS FOR A PARTICULAR PURPOSE, OR NONINFRINGEMENT OF THIRD-PARTY RIGHTS. IN NO EVENT WILL XILINX BE LIABLE FOR ANY CONSEQUENTIAL, INDIRECT, EXEMPLARY, SPECIAL, OR INCIDENTAL DAMAGES, INCLUDING ANY LOSS OF DATA OR LOST PROFITS, ARISING FROM YOUR USE OF THE DOCUMENTATION.

© 2007-2008 Xilinx, Inc. All rights reserved.

XILINX, the Xilinx logo, the Brand Window, and other designated brands included herein are trademarks of Xilinx, Inc. All other trademarks are the property of their respective owners.

---

## Revision History

The following table shows the revision history for this document.

Date	Version	Revision
10/29/07	1.0	Initial Xilinx release.
02/08/08	1.1	Addition to “ <a href="#">Video Starter Kit Contents.</a> ” Updated <a href="#">Figure 1-1</a> .
11/17/08	2.0	Updated for XtremeDSP Solution Video Starter Kit v2.0 (Spartan-3A DSP Edition).

# Contents

---

<b>Revision History</b> .....	2
<b>Overview</b> .....	5
<b>Video Starter Kit Contents</b> .....	5
<b>Getting Started with the Compact Flash Demonstrations</b> .....	6
<b>Installing the Software</b> .....	8
Step 1: Accessing the Xilinx Electronic Fulfillment Site .....	8
Step 2: Installing and Updating ISE, System Generator, and EDK Design Software .	8
Step 3: Register and Install Software .....	8
Now What? .....	9
<b>Service and Support</b> .....	9
Web Support – Knowledge On-Demand .....	9
Technical Support – Highly-Trained Specialists Available to Answer Your Questions	9
<b>Recorded Learning Module</b> .....	9
Education Courses – Training Solutions That Put You On The Fast Track To Success	10
QuickStart! – Get Your Design Off To The Right Start With Embedded Processing	
QuickStart! .....	10
Titanium Dedicated Engineering – It’s All About Efficiency .....	10
Xilinx Design Services - Your Expert Partners in FPGA Design .....	10



# *Spartan-3A DSP FPGA Video Starter Kit*

---

## Overview

This guide provides a brief overview of the Spartan®-3A DSP FPGA Video Starter Kit (VSK) and how to run a set of pre-defined demonstration designs.

The VSK enables the user to develop a wide range of video processing systems using a Xilinx® Spartan-3A DSP XC3SD3400A device, using a number of digital and analog video interfaces.

The latest revisions of the user guides and reference designs included with the kit are provided on the Xilinx website. It is strongly recommended that the user periodically check the Spartan-3A DSP Video Starter Kit [web page](#) to obtain the latest information and reference designs.

## Video Starter Kit Contents

The Video Starter Kit provides a Spartan-3A DSP FPGA Development Board populated with an FMC-Video daughter card. It is shipped with all the necessary power supplies, basic cables, and software needed for proper operation.

The following list of hardware is included in the Video Starter Kit:

- 1 – Spartan-3A DSP FPGA Development Board
- 1 – FMC-Video daughter card
- 1 – VGA Camera Module
- 1 – Power adapter and locale specific adapter
- 1 – S-Video cable
- 1 – RCA composite cable
- 1 – CAT 5 Ethernet crossover cable
- 1 – CAT 6 Ethernet patch cable
- 1 – DVI cable
- 1 – VGA cable
- 1 – Compact Flash card with boot image loaded
- 1 – Null modem cable
- 1 – Analog VGA to DVI adapter
- 1 – VSK Resource CD-ROM
- 1 – ISE® Design Suite 10.1 DVD

## Getting Started with the Compact Flash Demonstrations

Users can quickly experience some of the capabilities of the VSK by loading the configuration bitstreams included on the System Ace™ technology Compact Flash memory card. The configuration bitstreams were fully compiled for the four reference designs provided with the kit:

- DVI Pass-Through Demo
- DVI Frame-Buffer Demo
- Camera Frame-Buffer Demo
- S-Video Frame-Buffer Demo

To run the demos, set up the VSK as follows:

1. As shown in [Figure 1-1](#), set the power switch (S1) to OFF and insert the Compact Flash (CF) memory card into the Compact Flash slot (P7) on the board.

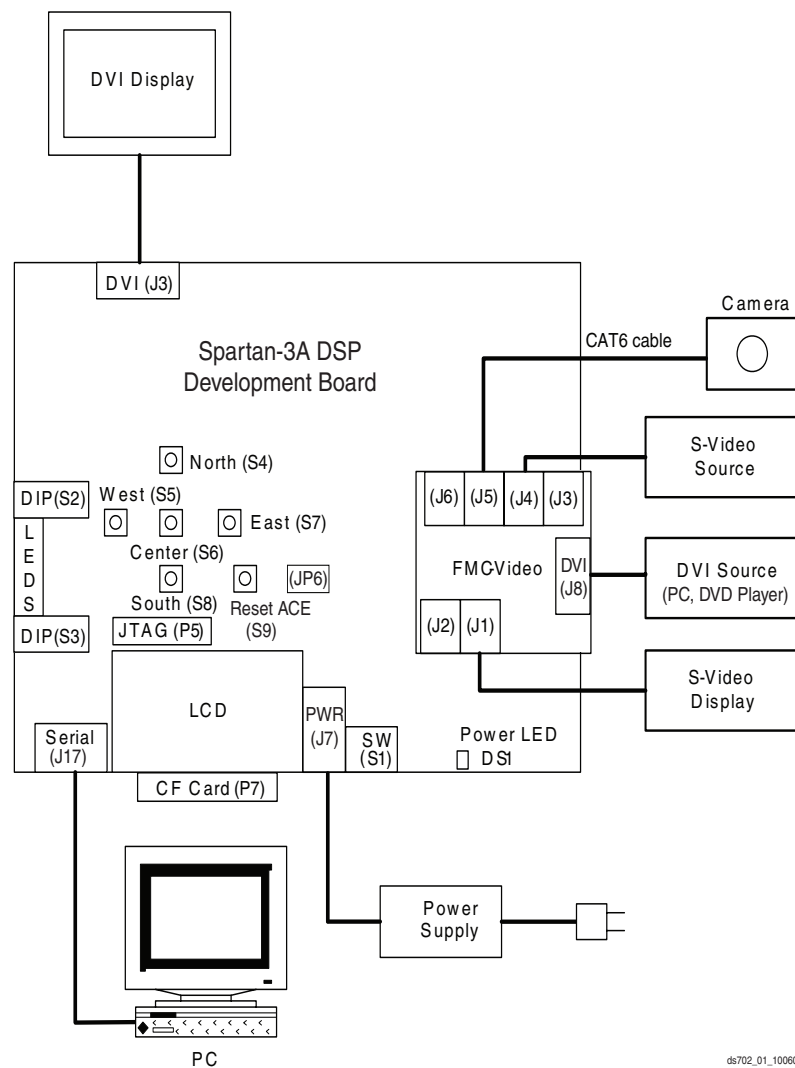

Figure 1-1: Video Starter Kit Physical Setup

ds702\_01\_100608

2. Verify that the boot mode DIP switch (S2) is set to 01010111 (arranged switch 1-8, 1 = ON). This allows a bootloader program to be loaded from the CF card by the System Ace controller. After the bootloader program has been loaded, the user is able to select a design to run by using the push buttons on the base board.
3. Verify the jumper JP6 is removed from the Spartan-3A DSP FPGA Development Board. This allows the on-board PLL to be programmed by the I<sup>2</sup>C bus.
4. To connect the VGA camera to the FMC-Video card using the supplied CAT6 cable, first plug one end into the Camera #1 RJ45 connector (J5) on the FMC-Video card. Then plug the other end of the CAT6 cable into the RJ45 connector on the VGA camera.

**Caution!** While the FMC-Video camera connector looks like a standard Ethernet connector, it is not compatible with Ethernet, and ONLY works with the VGA camera provided with the VSK. You may damage your equipment by connecting anything other than the VSK camera using the provided CAT 6 cable. To be sure, you have the correct cable, check that "CAT 6" is printed on the cable covering.

5. Connect a DVI monitor to the DVI output connector (J3) on the Spartan-3A DSP FPGA Development Board.  
**Note:** A VGA display may also be used by connecting the VGA cable to a VGA-to-DVI adapter that is then plugged into the DVI output connector (J3) on the Spartan-3A DSP FPGA Development Board.
6. Connect a DVI source to the DVI input connector (J8) on the FMC-Video.  
**Note:** A VGA source may also be used by connecting the VGA cable to a VGA-to-DVI adapter that is then plugged into the DVI input connector (J8) on the FMC-Video.
7. Connect an S-Video display to the S-Video output connector (J1) on the FMC-Video.
8. Connect an S-Video source to the S-Video input connector (J4) on the FMC-Video.
9. Connect a host PC to the Spartan-3A DSP FPGA Development Board with a 9-pin RS232 serial Null Modem cable. Connect one end of the cable to the RS232 Port (J17) on the Spartan-3A DSP FPGA Development Board and the other end of the cable to the serial port of the host PC.
10. Start and configure a HyperTerminal session on the host PC for 9600 baud, 8-bit, no parity, and no flow control. You will be able to interact with the demo through the HyperTerminal in real-time.
11. Connect the power supply to the Spartan-3A DSP FPGA Development Board power supply input (J7).
12. Switch the power switch (S1) on the Spartan-3A DSP FPGA Development Board to ON. The Power Good LED (DS1) on the Spartan-3A DSP FPGA Development Board should be illuminated, indicating that power is available.
13. Use the North (S4) and South (S8) push buttons on the Spartan-3A DSP FPGA Development Board to scroll through the demo selections and choose a demo to load. You should see this displayed on both the monitor and LCD display (DS21) on the Spartan-3A DSP FPGA Development Board.
14. Use the Center (S6) push button to load the demo. To reload the bootloader, press the Spartan-3A DSP FPGA Development Board push button labeled Reset ACE (S9).  
**Note:** For the DVI and S-Video demonstrations, the video source used to drive the VSK should be set to a resolution of 640x480P60, 800x600P60, 1024x768P60, 720P50, 720P60, 1080P25, 1080P30, 1080I50, or 1080I60 for proper operation. You should see the output of the video source shown on the display.

Each demo provides a series of menus, via the HyperTerminal program configured in step 10 above, that allow you to exercise all of the capabilities of the design. See the VSK User Guide ([UG456](#)) for more information about each of the demos.

## Installing the Software

The Xilinx® Spartan-3A DSP FPGA Video Starter Kit includes a Xilinx Software Development Suite DVD in the box, or you can download the software from the Xilinx software registration site. In both cases, you must register the software as part of the installation process. You cannot install the software until it has been registered.

### Step 1: Accessing the Xilinx Electronic Fulfillment Site

This development kit comes with *entitlement* to an *Evaluation* seat of the ISE® Foundation™ Design Software (ISE), a *Full* seat of the System Generator™ Design Suite, and a *Full* seat of the Embedded Development Kit (EDK) Design Suite product.

You should have received an E-mail for the Xilinx electronic fulfillment site and already may have had an opportunity to install the Xilinx software. If you have not done so, you may register and install your Xilinx software now.

**Note:** To determine the software you are entitled to (i.e., Full, Evaluation, or Free license), please visit the Xilinx software registration and entitlement site: [www.xilinx.com/register](http://www.xilinx.com/register)

To begin using the development kit software resources, the ISE Foundation, System Generator Design Suite, and the EDK Design Suite, you must first obtain installation keys. To do this, you may register or download these products immediately on the Xilinx Registration and Download Site at: [www.xilinx.com/register](http://www.xilinx.com/register)

### Step 2: Installing and Updating ISE, System Generator, and EDK Design Software

If you still need to install the ISE Foundation software, this video starter kit comes with *entitlement* to an Evaluation seat of the ISE Foundation Design Software.

If you still need to install the EDK Design Suite software, this video starter kit comes with *entitlement* to a Full seat of the Embedded Development Kit Design Suite products. After logging into the [www.xilinx.com/register](http://www.xilinx.com/register) site, select the check box for the Embedded Development Kit (EDK).

If you still need to install the System Generator software, this video starter kit comes with *entitlement* to a Full seat of the System Generator Design Suite products. After logging into the [www.xilinx.com/register](http://www.xilinx.com/register) site, select the check box for the System Generator software.

### Step 3: Register and Install Software

The System Generator Design Suite allows the user to create DSP-specific designs, while the Embedded Development Design Suite allows development of an embedded design, and the ISE Foundation allows the user to place and route a design. An installed version of System Generator, EDK, and ISE is needed before getting started. Any additional software may be selected for evaluation for a period of 60 days.

After making the desired product selections, click Next. An installation code is presented. Use this code to install the software from the Xilinx Software DVD in the Kit or use it with the software that was downloaded from the Xilinx software registration and download site [www.xilinx.com/register](http://www.xilinx.com/register).

Insert the Xilinx Software Development Suite DVD that came with the kit or select and install the Install image that was downloaded from the Xilinx registration and download site. Follow the instruction included in the installation software.

After you have installed the ISE, System Generator, and EDK software, make sure you also download the latest software updates. The latest software updates for all Xilinx products can be found on the Xilinx download site:

[www.xilinx.com/support/download/index.htm](http://www.xilinx.com/support/download/index.htm)

## Now What?

Congratulations, you have now successfully run some demonstrations on the Spartan-3A DSP FPGA Video Starter Kit and installed the Xilinx ISE, System Generator, and EDK software.

You now have an opportunity to learn how to customize your own hardware design, and write your own software application. You can find step-by-step instructions and additional resources on the product page at: [www.xilinx.com/vsk\\_s3](http://www.xilinx.com/vsk_s3)

You are encouraged to check this page regularly for the latest in documentation, examples, product updates, known issues, and links to evaluation and support by our Alliance Partners and other Xilinx partners.

## Service and Support

Xilinx provides all the support and services you need to shrink your development cycle and meet your design goals. From our world-class technical support to Design Services experts, Xilinx has the help you need, when you need it.

### Web Support – Knowledge On-Demand

The Xilinx support site provides many ways for you to find the answers you need, including available tools such as: Forums, Answer Browser, and My Alerts. Get the answers you need at our award-winning website. For more information, go to [www.xilinx.com/support](http://www.xilinx.com/support)

### Technical Support – Highly-Trained Specialists Available to Answer Your Questions

Our highly-trained engineers average 5+ years of industry experience. When you contact us, you will be routed directly to our team which specializes in embedded support. They will provide you the most up-to-date knowledge in embedded design. For more information, go to [www.xilinx.com/support](http://www.xilinx.com/support).

## Recorded Learning Module

Xilinx provides recorded e-Learning for course accessibility at your convenience. These training models are available at no charge; topics range from high-level software updates and ASIC to FPGA conversion strategies to specifics on device architecture.

Check one out today at: [www.xilinx.com/support/training/free-courses.htm](http://www.xilinx.com/support/training/free-courses.htm)

Xilinx webcasts are 60-minute live broadcasts featuring interactive technical presentations, product demonstrations, and question-and-answer sessions presented by our expert silicon and software people on Xilinx technology, the industry, or both. All broadcasts are made available for on-demand viewing within 24 hours of the live session. Register for a webcast live today at: [www.xilinx.com/events/webcasts.htm](http://www.xilinx.com/events/webcasts.htm)

Or check out the on-demand training at: [www.xilinx.com/events/webcasts\\_od.htm](http://www.xilinx.com/events/webcasts_od.htm).

## Education Courses – Training Solutions That Put You On The Fast Track To Success

Xilinx provides targeted, high quality education services designed by experts in programmable logic design, and delivered by Xilinx qualified trainers. Our series of instructor-led embedded classes include:

- Embedded Systems Development
- Advanced Embedded Systems Development
- Embedded Open-Source Linux.

For more information on Xilinx Education courses, go to: [www.xilinx.com/education](http://www.xilinx.com/education)

## QuickStart! – Get Your Design Off To The Right Start With Embedded Processing QuickStart!

Embedded QuickStart! provides you with accelerated *ramp-up* time to go to market faster. QuickStart! ensures a more knowledgeable team capable of executing better designs, lowering overall costs, and enhancing your competitive edge. QuickStart! provides an engineer at your site for one week. During that time, the Xilinx expert will train and empower your team to complete your project on time and make the best use of the Xilinx device you have selected. For more information, go to: [www.xilinx.com/quickstart](http://www.xilinx.com/quickstart)

## Titanium Dedicated Engineering – It's All About Efficiency

This robust service provides you, on a contract basis, with a dedicated Application Engineer, who can be remote or at your site. The Titanium engineer can help you with optimized hardware design and FPGA implementation, advanced Hardware/Software debugging, and complex IP integration.

For more information, go to: [www.xilinx.com/titanium](http://www.xilinx.com/titanium)

## Xilinx Design Services - Your Expert Partners in FPGA Design

Xilinx Design Services (XDS) combines logic, embedded software, and system-level skills to help optimize your use of the FPGA embedded infrastructure. XDS provides services to customers in all areas of FPGA development, from board bring-up and hardware IP implementation to BSP and RTOS integration, as well as developing market specific customer applications. XDS has successfully completed several customer engagements in data process, networking, and image processing applications. We also augment our technical skills with an ISO accredited project management process.

For more information, go to: [www.xilinx.com/xds](http://www.xilinx.com/xds)