

FPGA Broadcast Mezzanine Card

User Guide

UG753 (v1.0) June 8, 2010



Xilinx is disclosing this user guide, manual, release note, and/or specification (the “Documentation”) to you solely for use in the development of designs to operate with Xilinx hardware devices. You may not reproduce, distribute, republish, download, display, post, or transmit the Documentation in any form or by any means including, but not limited to, electronic, mechanical, photocopying, recording, or otherwise, without the prior written consent of Xilinx. Xilinx expressly disclaims any liability arising out of your use of the Documentation. Xilinx reserves the right, at its sole discretion, to change the Documentation without notice at any time. Xilinx assumes no obligation to correct any errors contained in the Documentation, or to advise you of any corrections or updates. Xilinx expressly disclaims any liability in connection with technical support or assistance that may be provided to you in connection with the Information.

THE DOCUMENTATION IS DISCLOSED TO YOU “AS-IS” WITH NO WARRANTY OF ANY KIND. XILINX MAKES NO OTHER WARRANTIES, WHETHER EXPRESS, IMPLIED, OR STATUTORY, REGARDING THE DOCUMENTATION, INCLUDING ANY WARRANTIES OF MERCHANTABILITY, FITNESS FOR A PARTICULAR PURPOSE, OR NONINFRINGEMENT OF THIRD-PARTY RIGHTS. IN NO EVENT WILL XILINX BE LIABLE FOR ANY CONSEQUENTIAL, INDIRECT, EXEMPLARY, SPECIAL, OR INCIDENTAL DAMAGES, INCLUDING ANY LOSS OF DATA OR LOST PROFITS, ARISING FROM YOUR USE OF THE DOCUMENTATION.

© Copyright 2010 Xilinx, Inc. XILINX, the Xilinx logo, Virtex, Spartan, ISE, and other designated brands included herein are trademarks of Xilinx in the United States and other countries. All other trademarks are the property of their respective owners.

Revision History

The following table shows the revision history for this document.

| Date | Version | Revision |
|----------|---------|-------------------------|
| 06/08/10 | 1.0 | Initial Xilinx release. |

Table of Contents

| | |
|---------------------------------------------------|----|
| Revision History | 2 |
| Preface: About This Guide | |
| Related Information..... | 5 |
| Additional Resources | 5 |
| FPGA Broadcast Mezzanine Card | |
| Introduction | 7 |
| Installation | 8 |
| Clock Block Diagram..... | 9 |
| FMC Card Control | 10 |
| Si5324 Device | 16 |
| LED Control | 18 |
| Clock Module Control | 19 |
| Clock Module GPIO | 23 |
| Clock Module Clock Signals..... | 24 |
| Clock Module I ² C Peek and Poke | 25 |
| CTSLCM1 Clock Module..... | 25 |
| Warranty..... | 27 |

About This Guide

This document introduces the FPGA broadcast mezzanine card, commonly referred to as the FMC card. It provides interfaces for professional broadcast audio and video equipment.

Related Information

These documents and product pages provide additional information relevant to the Virtex-6 FPGA Broadcast Kit:

- Virtex-6 FPGA Broadcast Kit product page
<http://www.xilinx.com/products/devkits/DK-V6-BCCN-G.htm>
- Virtex-6 FPGA Broadcast Kit documentation page
http://www.xilinx.com/products/boards/v6bck/reference_designs.htm
- Virtex-6 FPGA ML605 Evaluation Kit
<http://www.xilinx.com/products/devkits/EK-V6-ML605-G.htm>
- Spartan-6 FPGA SP605 Evaluation Kit
<http://www.xilinx.com/products/devkits/EK-S6-SP605-G.htm>
- XAPP1075, *Implementing Triple-Rate SDI with Virtex-6 FPGA GTX Transceivers*
http://www.xilinx.com/support/documentation/application_notes/xapp1075_V6GTX_TripleRateSDI.pdf

Additional Resources

To find additional documentation, see the Xilinx website at:

<http://www.xilinx.com/support/documentation/index.htm>.

To search the Answer Database of silicon, software, and IP questions and answers, or to create a technical support WebCase, see the Xilinx website at:

<http://www.xilinx.com/support>.

FPGA Broadcast Mezzanine Card

Introduction

The FPGA broadcast mezzanine card (FMC), or FMC card, plugs into the Virtex®-6 FPGA ML605 and Spartan®-6 FPGA SP605 evaluation boards (also referred to as carrier boards) to provide interfaces for professional broadcast audio and video equipment.

The basic features of the FMC card are:

- Compatibility with ML605 and SP605 carrier boards.
- Four input BNC connectors to support the triple-rate serial digital interface (SDI) which includes 3G-SDI, HD-SDI, and SD-SDI. (Only one GTP receiver is connected to the FMC card when connecting to the SP605 carrier board.)
- Four output BNC connectors to support triple-rate SDI. (Only one GTP transmitter is connected to the FMC card when connecting to the SP605 carrier board.)
- An external analog video sync BNC input connector and sync separator to provide horizontal and vertical sync signals to the carrier board. This allows the interfaces to be genlocked to an external video sync signal.
- Two AES3 RX BNC inputs and two AES3 TX BNC outputs to support up to four input and four output digital audio channels.
- AES10 input and output BNC connectors to support MADI.
- An expansion FMC connector allows expansion FMC mezzanine cards to be plugged onto the FMC card. This connector is for use primarily with an expansion card to add four more SDI input and output connectors. It is not compatible with all FMC mezzanine cards. At this time, an SDI expansion card for this connector is not available.
- Two sites for clock modules to provide flexible clocking resources. These sites are compatible with older clock modules designed for the ML571 serial digital video board, as well as new clock modules designed specifically for the FMC card. The clock modules can provide reference clocks to the serial transceivers on the carrier board. The clock modules can also provide other clock frequencies, such as audio clocks, to regional and global clock inputs of the carrier board FPGA. Each clock module can provide multiple clocks to the carrier board or to other clock synthesis resources on the FMC card.
- A Spartan®-3A FPGA controls all operations on the FMC card and provides a simple serial peripheral interface (SPI) to the carrier board.

Installation

The FMC card plugs into the HPC FMC connector on the ML605 carrier board or into the only FMC connector on the SP605 board. It draws all of its power from the carrier board through the FMC connector.

When connected to the ML605 carrier board, the FMC card interferes with some connectors along the top edge of the carrier board. It is difficult to plug the power connector from the power brick into the ML605 power connector with the FMC card installed. Xilinx provides a short adapter cable that allows the power brick to plug into the vertical ATX-style power connector located just below the regular power connector on the ML605 carrier board.

The carrier board can either include or exclude the JTAG chain of the FMC card into its JTAG chain. A jumper, located near the FMC connector, must be moved to include the FMC card in the carrier board JTAG chain. There are two devices on the FMC card JTAG chain, a Spartan-3A FPGA and a Xilinx® Platform Flash PROM used to program the Spartan-3A device.

The Spartan-3A FPGA can be configured from either the Platform Flash PROM, or through JTAG using the iMPACT (included in the ISE® development software tools) or ChipScope™ tools. For all standard SDI demonstrations, the Spartan-3A FPGA is configured from the Platform Flash PROM. If the revision of the code in the Platform Flash PROM is out-of-date and needs to be updated, the iMPACT tool can be used to burn a new MCS file into the Platform Flash PROM. This is accomplished by right-clicking on the xcf02s device icon shown in the iMPACT Boundary Scan view (Figure 1), selecting the **Assign New Configuration File...** option, and then right-clicking on the xcf02s device icon and selecting the **Program** option.

There is a JTAG jumper on the FMC card that allows the inclusion or exclusion of JTAG devices on an expansion FMC card plugged into the expansion FMC connector on the FMC card. If no expansion FMC card is plugged into the FMC card, or the expansion card does not have a JTAG chain, this jumper must be in the EXP_OUT position (jumper connecting the left two pins of the connector) for the FMC card JTAG chain to work. This jumper, labeled JTAG CONFIG, is located just below the expansion FMC connector.

Figure 1 shows the devices on the JTAG chain of the ML605 board and FMC card as viewed by the iMPACT tool.

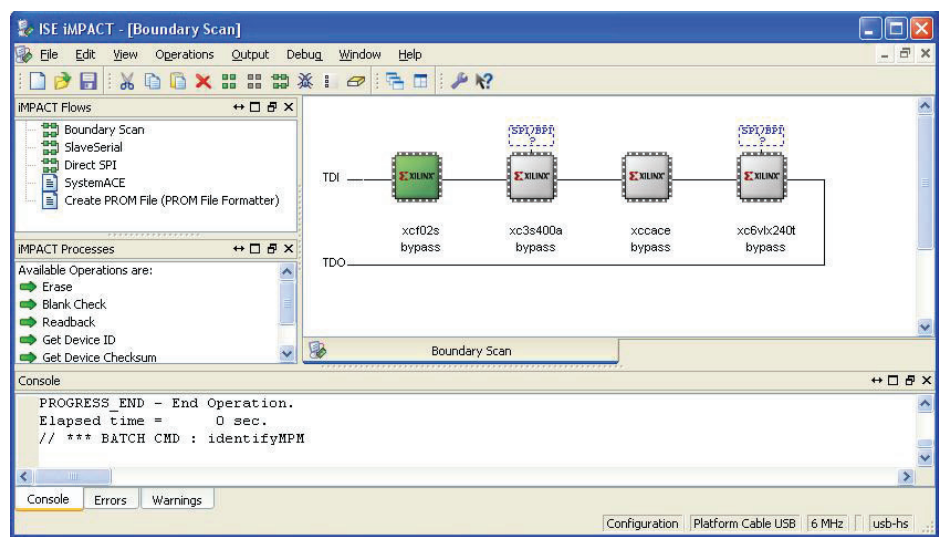

UG753_01_050410

Figure 1: ML605 Board and FMC Card JTAG Chain

Clock Block Diagram

The main clock paths of the FMC card are shown in [Figure 2](#). The Spartan-3A FPGA can provide either the 27 MHz local XO or the horizontal sync signal from the National Semiconductor LMH1981 sync separator to the Si5324 device, or, the Si5324 device can take a reference clock from the carrier board. If provided from the 27 MHz local XO, any of the standard SDI reference clock frequencies (148.5 MHz, 148.5/1.001 MHz, 74.25 MHz, and 74.25/1.001 MHz) can be synthesized. A 24.576 MHz clock frequency, often used for audio interfaces, can also be synthesized. If the horizontal sync signal is used, the Si5324 device can synthesize 27 MHz.

One output of the Si5324 device is connected to a global or regional clock pin on the FMC connector. The other output of the Si5324 device is connected to clock crossbar 1, where it can be routed to a serial transceiver reference clock pin, or to global or regional clock inputs of the FPGA on the carrier board.

The clocks from the clock modules are applied to the clock crossbars, directly to the FMC connector, or back to the Spartan-3A FPGA. The reference clock inputs to the clock modules can come from the FMC connector, the Spartan-3A FPGA, or from the clock crossbars.

The sync separator's outputs are applied to the Spartan-3A FPGA. The Spartan-3A FPGA can forward them to the FMC connector and to the Si5324 device. The Spartan-3A FPGA also processes the sync signals and determines the frame rate of the video sync signal.

Crossbar 3 handles high-speed signals from either the LVDS signals received via the FMC connector or from two of the serial transceiver outputs, also received from the FMC connector. It can route these signals to either of the other two crossbar switches or to two SDI TX outputs on the FMC card. To drive SDI TX1 and TX2, the signals from the DP0 and DP1 serial transceivers on the carrier board must pass through crossbar 3. Alternatively, these SDI TX outputs can be driven by the LVDS signal for slower speed protocols, such as SD-SDI and DVB-ASI. It is possible to use serial transmitters to synthesize clocks. Crossbar 3 supports this by allowing the output of either serial transmitter to be routed to clock crossbar 1 and clock crossbar 2.

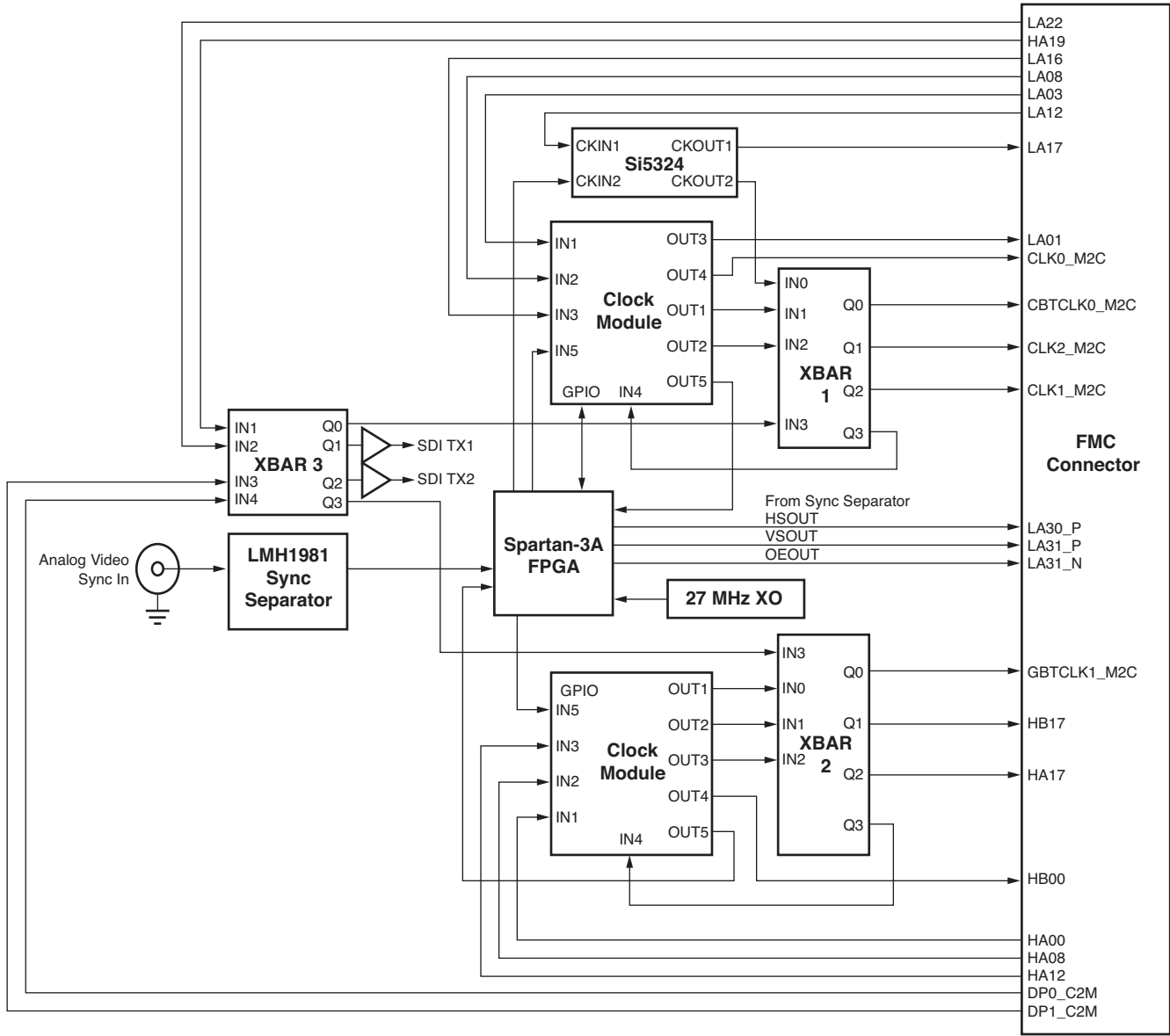

UG753_02_041110

Figure 2: Clock Paths Block Diagram

FMC Card Control

Almost all aspects of the FMC card are controlled by the Spartan-3A FPGA. The Spartan-3A FPGA is, in turn, controlled via SPI interfaces connected to the carrier board FPGA through the FMC connector. There are three separate SPI interfaces connected between the carrier board and the Spartan-3A FPGA. One is the main SPI interface for general control of the board. The other two SPI interfaces control the two clock modules. For all three of these SPI interfaces, the carrier board is the master.

The Spartan-3A FPGA interfaces with various devices and the clock modules on the FMC card through I²C or SPI serial interfaces, or by direct control signals. Figure 3 shows the various I²C and SPI interfaces on the FMC card.

The main_avb_control module provides a simplified control and status interface to the FMC card. This module is instantiated in the carrier board FPGA design. It contains an SPI master that handles all communications between the carrier board FPGA and the FMC card. The module's ports are identified in Table 1.

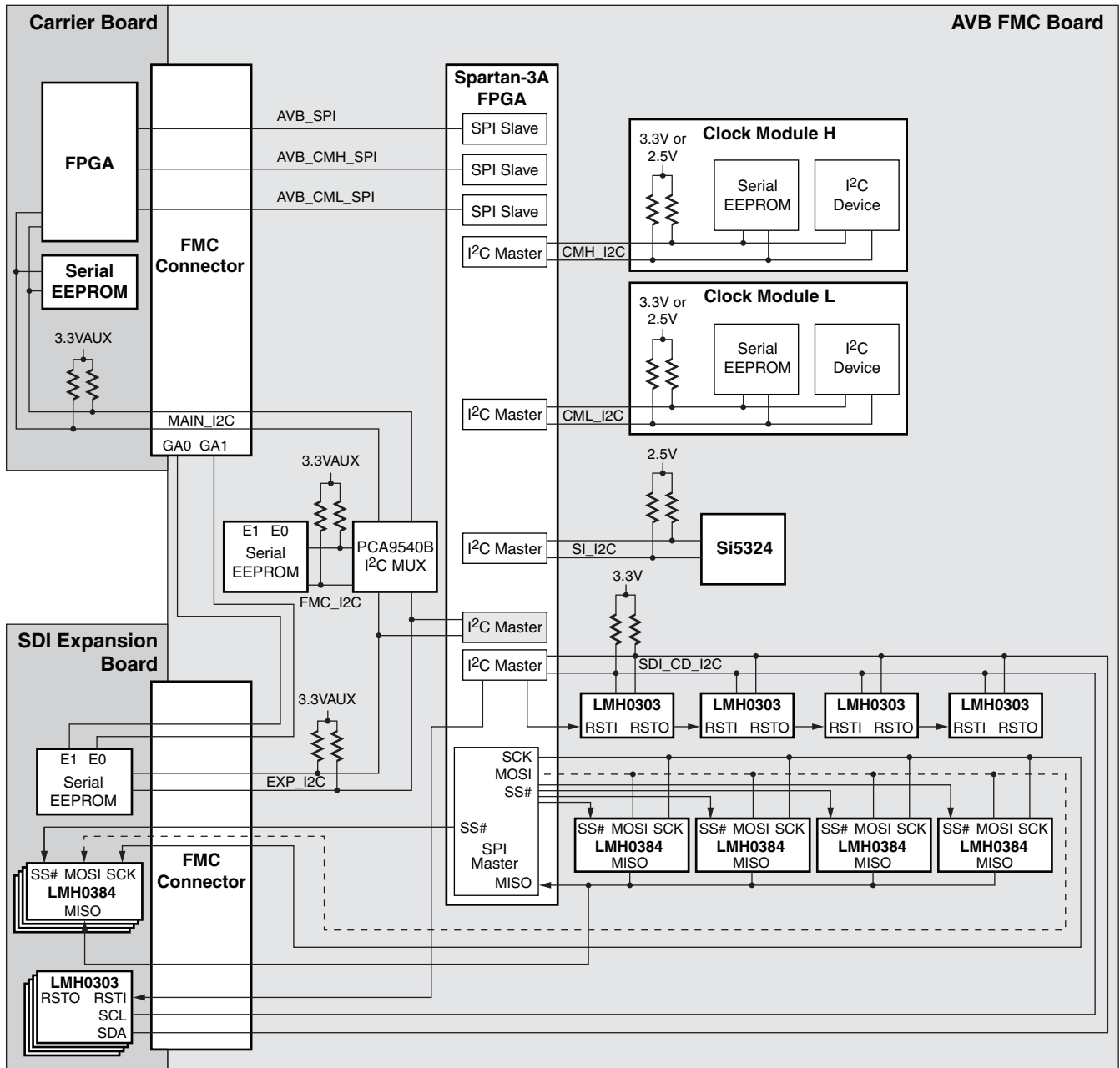

UG753_03_050310

Figure 3: I2C and SPI Interfaces

Note relevant to Figure 3:

- The MOSI line to the LMH0384 devices is routed as individual outputs from the Spartan-3A FPGA to each of the four LMH0384 devices on the FMC card and the four devices on the SDI expansion card. This is because the LMH0384 MOSI pin serves as the carrier on other cable equalizer devices. In SPI mode, all eight MOSI lines are

driven identically and act virtually as a single signal. This is represented in Figure 3 as a single dashed line to indicate the special nature of the signal.

Table 1: Port List for main_avb_control Module

| Name | Width | Direction | Description |
|-----------------|-------|-----------|------------------------------------------------------------------------------------------------------------------------------------------------------------------------------------------------------------------------------------------------------------------------------|
| clk | 1 | In | 27 MHz clock. Connects to the 27 MHz clock provided by the FMC card on FMC LVDS pair HB06 or LVTTTL signal LA18_N_CC (both signals always carry the 27 MHz clock). |
| rst | 1 | In | Resets the entire module. Typically, this can be tied Low. |
| sck | 1 | Out | Main SPI serial clock. Wired to FMC connector pin LA00_P_CC. |
| mosi | 1 | Out | Main SPI master serial data output. Wired to FMC connector pin LA00_N_CC. |
| miso | 1 | In | Main SPI master serial data input. Wired to FMC connector pin LA27_P. |
| ss | 1 | Out | Main SPI slave select signal. Wired to FMC connector pin LA14_N. |
| fpga_rev | 8 | Out | Indicates the revision of the Spartan-3A FPGA configuration on the FMC card. |
| exp_brd_prsnt | 1 | Out | Signal is High if there is an expansion FMC card plugged into the FMC card expansion FMC connector. |
| board_options | 8 | Out | Indicates build options of the FMC card. |
| xbar_1_out0_sel | 2 | In | Selects the signal to drive crossbar 1, output 0: <ul style="list-style-type: none"> • 00 = Si5324 • 01 = Clock module L, clock output 1 • 10 = Clock module L, clock output 2 • 11 = Crossbar 3, output 0 |
| xbar_1_out1_sel | 2 | In | Selects the signal to drive crossbar 1, output 1. Same choices as for xbar_1_out0_sel. |
| xbar_1_out2_sel | 2 | In | Selects the signal to drive crossbar 1, output 2. Same choices as for xbar_1_out0_sel. |
| xbar_1_out3_sel | 2 | In | Selects the signal to drive crossbar 1, output 3. Same choices as for xbar_1_out0_sel. |
| xbar_2_out0_sel | 2 | In | Selects the signal to drive crossbar 2, output 0: <ul style="list-style-type: none"> • 00 = Crossbar 3, output 3 • 01 = Clock module H, clock output 1 • 10 = Clock module H, clock output 2 • 11 = Clock module H, clock output 3 |
| xbar_2_out1_sel | 2 | In | Selects the signal to drive crossbar 2, output 1. Same choices as for xbar_2_out0_sel. |
| xbar_2_out2_sel | 2 | In | Selects the signal to drive crossbar 2, output 2. Same choices as for xbar_2_out0_sel. |
| xbar_2_out3_sel | 2 | In | Selects the signal to drive crossbar 2, output 3. Same choices as for xbar_2_out0_sel. |

Table 1: Port List for main_avb_control Module (Cont'd)

| Name | Width | Direction | Description |
|-------------------|-------|-----------|-----------------------------------------------------------------------------------------------------------------------------------------------------------------------------------------------------------------------------------------------------------------------------------------------------------------------------|
| xbar_3_out0_sel | 2 | In | Selects the signal to drive crossbar 3, output 0: <ul style="list-style-type: none"> • 00 = FMC LVDS pair HA19 • 01 = FMC LVDS pair LA22 • 10 = FMC serial transceiver DP0_C2M • 11 = FMC serial transceiver DP1_C2M |
| xbar_3_out1_sel | 2 | In | Selects the signal to drive crossbar 3, output 1. Same choices as for xbar_3_out0_sel. |
| xbar_3_out2_sel | 2 | In | Selects the signal to drive crossbar 3, output 2. Same choices as for xbar_3_out0_sel. |
| xbar_3_out3_sel | 2 | In | Selects the signal to drive crossbar 3, output 3. Same choices as for xbar_3_out0_sel. |
| Si5324_reset | 1 | In | A High on this port resets the main Si5324 chip on the FMC card. |
| Si5324_clkin_sel | 2 | In | Selects the clock input and operating mode of the main Si5324 on the FMC card. See Si5324 Device , page 16 for details. |
| Si5324_out_fsel | 4 | In | Selects from a predefined set of output frequencies for the Si5324. See Si5324 Device for details. |
| Si5324_in_fsel | 5 | In | Selects from a predefined set of input frequencies for the Si5324. See Si5324 Device for details. |
| Si5324_bw_sel | 4 | In | Selects the bandwidth of the Si5324 device. Only legal Si5324 device bandwidth settings can be used. The legal settings vary based on the Si5324_out_fsel and Si5324_in_fsel settings. Consult the <code>Si5324_Bandwidth_Settings.htm</code> file included with the reference design files to determine the correct value. |
| Si5324_DHOLD | 1 | In | Driving this port High places the Si5324 device in digital holdover mode. For normal operation, this input must be Low. |
| Si5324_FOS2 | 1 | Out | When High, this indicates a frequency offset error on CKIN2 of the Si5324 device. |
| Si5324_FOS1 | 1 | Out | When High, this indicates a frequency offset error on CKIN1 of the Si5324 device. |
| Si5234_LOL | 1 | Out | When High, this indicates that the Si5324 device PLL is not locked to the input reference clock. |
| Si5324_reg_adr | 8 | In | Register address to peek or poke a register in the Si5234. |
| Si5324_reg_wr_dat | 8 | In | Data to be poked into a register in the Si5324 device. |
| Si5324_reg_rd_dat | 8 | Out | Data read from a register in the Si5324 device during a peek operation. |
| Si5324_reg_wr | 1 | In | This input is asserted High for one clk cycle to initiate a poke into a register in the Si5324 device. The Si5324_reg_adr and Si5324_reg_wr_dat ports must be set up prior to asserting this input. This input must not be asserted if Si5324_reg_rdy is Low. |

Table 1: Port List for main_avb_control Module (Cont'd)

| Name | Width | Direction | Description |
|-----------------|-------|-----------|----------------------------------------------------------------------------------------------------------------------------------------------------------------------------------------------------------------------------------------------------------------------------------------------------------------------------------------------------------------------------------------------------------------------------------------------------------------------|
| Si5324_reg_rd | 1 | In | This input is asserted High for one clk cycle to initiate a peek of a register in the Si5324 device. The register address must be set up on Si5324_reg_adr prior to asserting this signal. This input must not be asserted if Si5324_reg_rdy is Low. On the rising edge of clk when this input is High, Si5324_reg_rdy goes Low and stays Low until the data has been read from the Si5324 register and output on Si5324_reg_rd_dat. |
| Si5324_reg_rdy | 1 | Out | This output is asserted High when the module is ready to accept a new Si5324 register peek or poke request. If this input is Low, the module is executing the last peek or poke request. |
| Si5324_error | 1 | Out | This output is asserted High if the last peek or poke request was NACKed by the Si5324 device on the I ² C bus. |
| sync_video_fmt | 11 | Out | This port indicates the number of horizontal sync pulses per field of the external video sync signal as reported by the LMH1981 multi-format video sync separator. This number fluctuates when the video sync signal is an interlaced format with different numbers of lines in the two fields. Refer to the <i>LMH1981 Multi-Format Video Sync Separator</i> data sheet at http://www.national.com/analog for details. |
| sync_updating | 1 | Out | The sync_video_fmt port is only valid when this output is Low. |
| sync_frame_rate | 3 | Out | Indicates the frame rate of the external video sync signal. This is always the frame rate, even for interlaced video. <ul style="list-style-type: none"> • 000 = 23.98 Hz • 001 = 24 Hz • 010 = 25 Hz • 011 = 29.97 Hz • 100 = 30 Hz • 101 = 50 Hz • 110 = 59.94 Hz • 111 = 60 Hz |
| sync_m | 1 | Out | This output is Low for frame rates of 24, 25, 30, 50, and 60 Hz. It is High for frame rates of 23.98, 29.97, and 59.94 Hz. |
| sync_error | 1 | Out | This output is High if the rate detector cannot determine the frame rate of the external sync signal. |
| sdi_rx1_led | 2 | In | Controls the SDI RX1 LEDs. See LED Control, page 18 for details. |
| sdi_rx2_led | 2 | In | Controls the SDI RX2 LEDs. |
| sdi_rx3_led | 2 | In | Controls the SDI RX3 LEDs. |
| sdi_rx4_led | 2 | In | Controls the SDI RX4 LEDs. |
| sdi_rx5_led | 2 | In | Controls the SDI RX5 LEDs. The SDI RX5 LEDs are only available if the SDI expansion card is connected to the FMC card. |
| sdi_rx6_led | 2 | In | Controls the SDI RX6 LEDs. The SDI RX6 LEDs are only available if the SDI expansion card is connected to the FMC card. |
| sdi_rx7_led | 2 | In | Controls the SDI RX7 LEDs. The SDI RX7 LEDs are only available if the SDI expansion card is connected to the FMC card. |

Table 1: Port List for main_avb_control Module (Cont'd)

| Name | Width | Direction | Description |
|-----------------|--------------|------------------|---------------------------------------------------------------------------------------------------------------------------|
| sdi_rx8_led | 2 | In | Controls the SDI RX8 LEDs. The SDI RX8 LEDs are only available if the SDI expansion card is connected to the FMC card. |
| sdi_tx1_red_led | 2 | In | Controls the SDI TX1 red LED. |
| sdi_tx1_grn_led | 2 | In | Controls the SDI TX1 green LED. |
| sdi_tx2_red_led | 2 | In | Controls the SDI TX2 red LED. |
| sdi_tx2_grn_led | 2 | In | Controls the SDI TX2 green LED. |
| sdi_tx3_red_led | 2 | In | Controls the SDI TX3 red LED. |
| sdi_tx3_grn_led | 2 | In | Controls the SDI TX3 green LED. |
| sdi_tx4_red_led | 2 | In | Controls the SDI TX4 red LED. |
| sdi_tx4_grn_led | 2 | In | Controls the SDI TX4 green LED. |
| sdi_tx5_red_led | 2 | In | Controls the SDI TX5 red LED. The SDI TX5 LEDs are only available if the SDI expansion card is connected to the FMC card. |
| sdi_tx5_grn_led | 2 | In | Controls the SDI TX5 green LED. |
| sdi_tx6_red_led | 2 | In | Controls the SDI TX6 red LED. The SDI TX6 LEDs are only available if the SDI expansion card is connected to the FMC card. |
| sdi_tx6_grn_led | 2 | In | Controls the SDI TX6 green LED. |
| sdi_tx7_red_led | 2 | In | Controls the SDI TX7 red LED. The SDI TX7 LEDs are only available if the SDI expansion card is connected to the FMC card. |
| sdi_tx7_grn_led | 2 | In | Controls the SDI TX7 green LED. |
| sdi_tx8_red_led | 2 | In | Controls the SDI TX8 red LED. The SDI TX8 LEDs are only available if the SDI expansion card is connected to the FMC card. |
| sdi_tx8_grn_led | 2 | In | Controls the SDI TX8 green LED. |
| aes_rx1_red_led | 2 | In | Controls the AES3 RX1 red LED. |
| aes_rx1_grn_led | 2 | In | Controls the AES3 RX1 green LED. |
| aes_rx2_red_led | 2 | In | Controls the AES3 RX2 red LED. |
| aes_rx2_grn_led | 2 | In | Controls the AES3 RX2 green LED. |
| aes_tx1_red_led | 2 | In | Controls the AES3 TX1 red LED. |
| aes_tx1_grn_led | 2 | In | Controls the AES3 TX1 green LED. |
| aes_tx2_red_led | 2 | In | Controls the AES3 TX2 red LED. |
| aes_tx2_grn_led | 2 | In | Controls the AES3 TX2 green LED. |
| madi_rx_red_led | 2 | In | Controls the AES10 RX red LED. |
| madi_rx_grn_led | 2 | In | Controls the AES10 RX green LED. |
| madi_tx_red_led | 2 | In | Controls the AES10 TX red LED. |
| madi_tx_grn_led | 2 | In | Controls the AES10 TX green LED. |
| sync_red_led | 2 | In | Controls the external sync red LED. |

Table 1: Port List for main_avb_control Module (Cont'd)

| Name | Width | Direction | Description |
|---------------------|-------|-----------|------------------------------------------------------------------------------------------------------------------------------------------------------------------------------------------------------------------------------------------------------------------------------------------------------------------------------------------------------------------------------------------------------------------------------------------------------------------|
| sync_grn_led | 2 | In | Controls the external sync green LED. |
| sdi_eq_cd_n | 8 | Out | Indicates the carrier detect (CD) status of the eight SDI cable equalizers. Each bit is asserted Low if the corresponding equalizer is detecting a valid carrier signal. Bit 0 corresponds to SDI RX1. Bit 7 corresponds to SDI RX8. SDI RX4 through RX8 are only available if the SDI expansion card is connected to the FMC card. |
| sdi_eq_ext_3G_reach | 8 | In | Enables the extended 3G-SDI reach control algorithm for each SDI cable equalizer. The algorithm is enabled for an equalizer if the corresponding bit is High. Bit 0 corresponds to SDI RX1, and bit 7 corresponds to SDI RX8. Refer to the <i>LMH0384 3 Gbps HD/SD SDI Extended Reach and Configurable Adaptive Cable Equalizer</i> data sheet at http://www.national.com/analog for details of this algorithm. |
| sdi_eq_select | 3 | In | Selects which SDI cable equalizer's cable length indicator (CLI) value is output on the sdi_eq_cli port. |
| sdi_eq_cli | 8 | Out | The CLI value of the SDI cable equalizer selected by the sdi_eq_select port is output on this port. It is continuously updated. Refer to the <i>LMH0384 3 Gbps HD/SD SDI Extended Reach and Configurable Adaptive Cable Equalizer</i> data sheet at http://www.national.com/analog for details about the CLI value. |
| sdi_drv_hd_sd | 8 | In | Selects the slew rate of each SDI cable driver. The cable driver's bit is driven Low for HD-SDI and 3G-SDI, and High for SD-SDI. Bit 0 corresponds to SDI TX1, and bit 7 corresponds to SDI TX8. |
| sdi_drv_enable | 8 | In | These bits enable the SDI cable drivers. The cable driver's enable bit is driven High to enable the cable driver, and Low for low power mode. Bit 0 corresponds to SDI TX1, and bit 7 corresponds to SDI TX8. |
| sdi_drv_fault_n | 8 | Out | These bits reflect the status of the FAULT output of each SDI cable driver. If a bit is Low, the corresponding cable driver is reporting a fault. That fault can be caused by either no signal on its input or an improperly terminated output load (usually no cable plugged into the connector). To automatically power down SDI cable drivers when they have no load, the eight bits of this port are connected to the eight bits of the sdi_drv_enable port. |

Si5324 Device

The Si5324 device on the FMC card primarily provides a reference clock to the serial transceivers on the carrier board. It can also be used as one of the two frequency synthesis chips needed to implement a genlock solution.

This device provides versatile clock synthesis capabilities. It also can be programmed with very low loop filter bandwidth to reduce low frequency jitter.

The Si5324 device has two clock inputs. One input is driven by the Spartan-3A FPGA, and the other is driven by an LVDS pair from the FMC connector. A two-bit port called Si5324_clk_in_sel selects the reference clock source for the Si5324 device, as shown in [Table 2](#).

Table 2: Si5324 Device Clock Input Source Selection

| Si5324_clkin_sel | Clock Source |
|------------------|--------------------------------------|
| 00 | 27 MHz XO |
| 01 | External video sync – automatic mode |
| 10 | FMC LA29 LVDS pair |
| 11 | External video sync – manual mode |

The Spartan-3A FPGA either provides the 27 MHz clock or the external horizontal sync signal to CKIN2 on the Si5324 device. The FMC LA29 LVDS pair is always wired to CKIN1. The Spartan-3A FPGA selects either CKIN1 or CKIN2 based on the Si5324_clkin_sel value.

If the external video sync signal is selected as the reference to the Si5324 device, either automatic or manual mode can be chosen. In automatic mode, the Spartan-3A FPGA determines the frequency of the external sync signal, and automatically programs the input clock frequency of the Si5324 device. In manual mode, the carrier board FPGA specifies the input clock frequency via the Si5324_in_fsel port, as shown in Table 3. The Si5324_out_fsel port specifies the output frequency as shown in Table 3. The Si5324_out_fsel port is four bits wide, and selections 1000 and 1001 are reserved to generate 297 MHz and 297/1.001 MHz, respectively, but these two frequencies are not yet fully supported.

The Spartan-3A FPGA is pre-programmed to support the set of input and output frequency combinations shown in Table 3. Only those combinations with a checkmark are supported as pre-programmed combinations on the FMC card. Other frequency synthesis mappings can be programmed into the Si5324 device using the Si5324 register peek/poke ports.

Table 3: Pre-Programmed Si5324 Input/Output Frequency Combinations

| Si5324_out_fsel Si5324_in_fsel | 0000 27 MHz | 0001 74.25 MHz | 0010 74.1758 MHz | 0011 148.5 MHz | 0100 148.3516 MHz | 0101 24.576 MHz | 0110 148.4258 MHz |
|-----------------------------------|----------------|-------------------|---------------------|-------------------|----------------------|--------------------|----------------------|
| 0x00 = 480i (NTSC) | ✓ | | | | | | |
| 0x01 = 480p | ✓ | | | | | | |
| 0x02 = 576i (PAL) | ✓ | | | | | | |
| 0x03 = 576p | ✓ | | | | | | |
| 0x04 = 720p 24 Hz | ✓ | | | | | | |
| 0x05 = 720p 23.98 Hz | ✓ | | | | | | |
| 0x06 = 720p 25 Hz | ✓ | | | | | | |
| 0x07 = 720p 30 Hz | ✓ | | | | | | |
| 0x08 = 720p 29.97 Hz | ✓ | | | | | | |
| 0x09 = 720p 50 Hz | ✓ | | | | | | |
| 0x0A = 720p 60 Hz | ✓ | | | | | | |
| 0x0B = 720p 59.94 Hz | ✓ | | | | | | |
| 0x0C = 1080i 50 Hz | ✓ | | | | | | |
| 0x0D = 1080i 60 Hz | ✓ | | | | | | |

Table 3: Pre-Programmed Si5324 Input/Output Frequency Combinations (Cont'd)

| Si5324_out_fsel Si5324_in_fsel | 0000 27 MHz | 0001 74.25 MHz | 0010 74.1758 MHz | 0011 148.5 MHz | 0100 148.3516 MHz | 0101 24.576 MHz | 0110 148.4258 MHz |
|-----------------------------------|----------------|-------------------|---------------------|-------------------|----------------------|--------------------|----------------------|
| 0x0E = 1080i 59.94 Hz | ✓ | | | | | | |
| 0x0F = 1080p 24 Hz | ✓ | | | | | | |
| 0x10 = 1080p 23.98 Hz | ✓ | | | | | | |
| 0x11 = 1080p 25 Hz | ✓ | | | | | | |
| 0x12 = 1080p 30 Hz | ✓ | | | | | | |
| 0x13 = 1080p 29.97 Hz | ✓ | | | | | | |
| 0x14 = 1080p 50 Hz | ✓ | | | | | | |
| 0x15 = 1080p 60 Hz | ✓ | | | | | | |
| 0x16 = 1080p 59.94 Hz | ✓ | | | | | | |
| 0x17 = 27 MHz | ✓ | ✓ | ✓ | ✓ | ✓ | ✓ | ✓ |
| 0x18 = 74.25 MHz | ✓ | ✓ | ✓ | ✓ | ✓ | ✓ | ✓ |
| 0x19 = 74.1758 MHz | ✓ | ✓ | ✓ | ✓ | ✓ | | |
| 0x1A = 148.5 MHz | ✓ | ✓ | ✓ | ✓ | ✓ | ✓ | ✓ |
| 0x1B = 148.3516 MHz | ✓ | ✓ | ✓ | ✓ | ✓ | | |

As identified in [Table 3](#), the Si5324 device only generates 27 MHz output clocks when fed a video sync signal. To implement a genlocked SDI transmitter, for example, the reference clock frequency to the serial transceiver must be 74.25 MHz, 74.1758 MHz, 148.5 MHz, or 148.3516 MHz. Two Si5324 devices can be connected in series with the first one converting the video sync signal to 27 MHz and the second one converting the 27 MHz to the required serial transceiver reference clock frequency. This requires the addition of additional Si5324 devices by adding a Si5324 clock module to one of the clock module sites on the FMC card.

The Si5324 device cannot always generate a 24.576 MHz audio clock from all input clock frequencies. Cascading two Si5324 devices can solve this problem by first converting the input clock to 27 MHz in the first device and then converting it to 24.576 MHz in the second device.

LED Control

Each BNC connector on the FMC card has a red/green LED next to it to indicate the status associated with that connector. The `main_avb_control` module allows the carrier board FPGA to control all of these LEDs. Control ports are also provided to control the LEDs next to the four SDI TX connectors and four SDI RX connectors on the SDI expansion card that can be connected to the expansion FMC connector on the FMC card.

The eight possible SDI RX LEDs (four on the FMC card and four on the SDI expansion card) are controlled by eight two-bit ports. For example, the port named `sdi_rx1_led` controls the red and green LEDs next to the SDI RX1 connector. The LEDs are controlled as shown in [Table 4](#). For any active SDI RX connector, mode 11 should be used. This allows the LED to be controlled automatically by the cable equalizer carrier detect signal.

Table 4: SDI RX LED Control

| sdi_rxn_led | LED |
|-------------|--------------------------------------------------|
| 00 | Off |
| 01 | Green On |
| 10 | Red On |
| 11 | Green if cable EQ CD is asserted, red otherwise. |

For all other LEDs, there are separate two-bit ports to independently control the red and green sides of the LED as shown in Table 5.

Table 5: LED Control for All But SDI RX LEDs

| sdi_rxn_led | LED |
|-------------|-------------|
| 00 | Off |
| 01 | On |
| 10 | Slow flash |
| 11 | Rapid flash |

Clock Module Control

There are sites for two clock modules on the FMC card. Clock module H is primarily associated with signals only available if the FMC card is connected to an HPC FMC connector. Clock module L is associated with signals available on either the LPC or the HPC FMC connector.

The carrier board FPGA controls each clock module via a dedicated SPI interface, one SPI interface for each clock module. Different clock modules have different control requirements. Some of them have I²C interfaces. The Spartan-3A FPGA contains an I²C master for each clock module which is, in turn, controlled by the SPI interface from the carrier board. Most clock modules have a number of discrete input and output signals. Some of these discrete signals can be connected either directly or through the Spartan-3A FPGA to FMC signals. Others must be controlled or monitored by the carrier board indirectly through the SPI interface.

A module called `cm_avb_control` can be instantiated in the FPGA on the ML605 or SP605 boards to control one clock module. If both clock modules are installed on the FMC card, then two instances of the `cm_avb_control` module need to be instantiated in the FPGA, one for each clock module. This module can be used to control any type of clock module, but is specifically designed to control the Cook Technologies CTSLCM1 clock module that has three Si5324 devices on it. The module's ports are identified in Table 6.

Table 6: Port List for `cm_avb_control` Module

| Name | Width | Direction | Description |
|------|-------|-----------|--------------------------------------------------------------------------------------------------------------------------------------------------------------------|
| clk | 1 | In | 27 MHz clock. Connects to the 27 MHz clock provided by the FMC card on FMC LVDS pair HB06 or LVTTTL signal LA18_N_CC (both signals always carry the 27 MHz clock). |
| rst | 1 | In | Resets the entire module. Typically, this can be tied Low. |

Table 6: Port List for cm_avb_control Module (Cont'd)

| Name | Width | Direction | Description |
|-------------------|-------|-----------|-----------------------------------------------------------------------------------------------------------------------------------------------------------------------------------------------------------------------------------------------------------------------------------------------------------------------------------------------------------------------------------------------------------------------------------------------------|
| sck | 1 | Out | Clock module SPI serial clock. Connects to FMC connector pin LA29_P for clock module L, to HB11_N for clock module H. |
| mosi | 1 | Out | Clock module SPI master serial data output. Connects to FMC connector LA07_P for clock module L, to HB07_P for clock module H. |
| miso | 1 | In | Clock module SPI master serial data input. Connects to FMC connector LA29_N for clock module L, to HA05_P for clock module H. |
| ss | 1 | Out | Clock module SPI slave select signal. Connects to FMC connector LA07_N for clock module L, to HA05_N for clock module H. |
| module_type | 16 | Out | Indicates the clock module type. A value of 0x0001 indicates the CTSLCM1 module. Older clock modules do not have identification PROMs and cannot be automatically identified. |
| module_rev | 16 | Out | Indicates the revision of the clock module. Older clock modules do not have identification PROMs and cannot be automatically identified. |
| module_type_valid | 1 | Out | This output goes High when the FMC card has identified the module type and revision, and outputs the values on the module_type and module_rev ports. |
| module_type_error | 1 | Out | This output goes High if the FMC card receives an I ² C bus NACK while attempting to read the module type and revision from the clock module. |
| clkin5_src_sel | 1 | In | This input controls a multiplexer in the Spartan-3A FPGA on the FMC card. This multiplexer selects the source of the signal that drives the clock IN5 input of the clock module. If this input is Low, the local 27 MHz XO on the FMC card is routed to clock IN5. If this input is High, an LVDS pair on the FMC connector is routed to clock IN5. For clock module L, this LVDS pair is LA28_P/N. For clock module H, this LVDS pair is HB05_P/N. |
| gpio_dir_0 | 8 | In | Specifies the direction of clock module the GPIO[7:0] signals. See Clock Module GPIO, page 23 for details. (0 = output to clock module, 1 = input from clock module.) |
| gpio_dir_1 | 8 | In | Specifies the direction of clock module the GPIO[15:8] signals. See Clock Module GPIO for details. (0 = output to clock module, 1 = input from clock module.) |
| gpio_dir_2 | 8 | In | Specifies the direction of clock module the GPIO[23:16] signals. See Clock Module GPIO for details. (0 = output to clock module, 1 = input from clock module.) |
| gp_out_value_0 | 8 | In | Specifies the value to be output to the clock module on the GPIO[7:0] signals that are configured as outputs. |
| gp_out_value_1 | 8 | In | Specifies the value to be output to the clock module on the GPIO[15:8] signals that are configured as outputs. |
| gp_out_value_2 | 8 | In | Specifies the value to be output to the clock module on the GPIO[23:16] signals that are configured as outputs. |
| gp_in_value_0 | 8 | Out | Indicates the current value of the clock module GPIO[7:0] signals that are programmed as inputs. |

Table 6: Port List for cm_avb_control Module (Cont'd)

| Name | Width | Direction | Description |
|-----------------------------------------------------------------------------------------------------------------------------------------------------|-------|-----------|----------------------------------------------------------------------------------------------------------------------------------------------------------------------------------------------------------------------------------------------------------------------------------------------------|
| gp_in_value_1 | 8 | Out | Indicates the current value of the clock module GPIO[15:8] signals that are programmed as inputs. |
| gp_in_value_2 | 8 | Out | Indicates the current value of the clock module GPIO[23:16] signals that are programmed as inputs. |
| gp_in | 4 | Out | Indicates the current value of the clock module GPIN[3:0] signals. These are outputs of the clock module to the Spartan-3A FPGA on the FMC card. |
| i2c_slave_adr | 8 | In | I ² C bus slave address. See Clock Module I2C Peek and Poke, page 25 for details. |
| i2c_reg_adr | 8 | In | I ² C bus register address. See Clock Module I2C Peek and Poke for details. |
| i2c_reg_dat_wr | 8 | In | Data written during the next I ² C bus poke operation. See Clock Module I2C Peek and Poke for details. |
| i2c_reg_wr | 1 | In | A High on this port causes an I ² C bus poke operation. See Clock Module I2C Peek and Poke for details. |
| i2c_reg_rd | 1 | In | A High on this port causes an I ² C bus peek operation. See Clock Module I2C Peek and Poke for details. |
| i2c_reg_dat_rd | 8 | Out | Data read from clock module during last peek operation. See Clock Module I2C Peek and Poke for details. |
| i2c_reg_rdy | 1 | Out | When this output is High, the previously requested peek or poke operation has been completed and a new peek or poke operation may be requested. See Clock Module I2C Peek and Poke for details. |
| i2c_reg_error | 1 | Out | When this output is High, the previously requested peek or poke operation received an I ² C bus NACK. See Clock Module I2C Peek and Poke for details. |
| These ports are only valid when controlling a CTSLCM1 clock module. There are three Si5324 devices on this module identified as A, B, and C. | | | |
| Si5324_A_clkin_sel | 1 | In | Controls the clock in the select multiplexer of Si5324 A: <ul style="list-style-type: none"> • 0 = select CKIN1 • 1 = select CKIN2 |
| Si5324_A_out_fsel | 4 | In | Selects the output frequency of Si5324 A. See Table 3, page 17 . |
| Si5324_A_in_fsel | 5 | In | Specifies the input frequency of the reference clock provided to Si5324 A. See Table 3 . |
| Si5324_A_bw_sel | 4 | In | Selects the bandwidth of the Si5324 A. Only legal Si5324 bandwidth settings can be used. The legal settings vary based on the Si5324_out_fsel and Si5324_in_fsel settings. Consult the Si5324 Bandwidth Settings.htm file included with the reference design files to determine the correct value. |
| Si5324_A_DHOLD | 1 | In | Driving this port High places the Si5324 A in digital holdover mode. For normal operation, this input must be Low. |
| Si5324_A_FOS2 | 1 | Out | When High, this indicates a frequency offset error on CKIN2 of Si5324 A. |
| Si5324_A_FOS1 | 1 | Out | When High, this indicates a frequency offset error on CKIN1 of Si5324 A. |
| Si5324_A_LOL | 1 | Out | When High, this indicates that the Si5324 A PLL is not locked to the input reference clock. |

Table 6: Port List for cm_avb_control Module (Cont'd)

| Name | Width | Direction | Description |
|---------------------|-------|-----------|---------------------------------------------------------------------------------------------------------------------------------------------------------------------------------------------------------------------------------------------------------------------------------------------------------------------------|
| Si5324_B_clk_in_sel | 1 | In | Controls the clock in the select multiplexer of Si5324 B: <ul style="list-style-type: none"> • 0 = select CKIN1 • 1 = select CKIN2 |
| Si5324_B_out_fsel | 4 | In | Selects the output frequency of Si5324 B. See Table 3, page 17 . |
| Si5324_B_in_fsel | 5 | In | Specifies the input frequency of the reference clock provided to Si5324 B. See Table 3 . |
| Si5324_B_bw_sel | 4 | In | Selects the bandwidth of the Si5324 B. Only legal Si5324 device bandwidth settings can be used. The legal settings vary based on the Si5324_out_fsel and Si5324_in_fsel settings. Consult the Si5324 Bandwidth Settings.htm file included with the reference design files to determine the correct value. |
| Si5324_B_DHOLD | 1 | In | Driving this port High places the Si5324 B in digital holdover mode. For normal operation, this input must be Low. |
| Si5324_B_FOS2 | 1 | Out | When High, this indicates a frequency offset error on CKIN2 of Si5324 B. |
| Si5324_B_FOS1 | 1 | Out | When High, this indicates a frequency offset error on CKIN1 of Si5324 B. |
| Si5324_B_LOL | 1 | Out | When High, this indicates that the Si5324 B PLL is not locked to the input reference clock. |
| Si5324_C_clk_in_sel | 1 | In | Controls the clock in the select multiplexer of Si5324 C: <ul style="list-style-type: none"> • 0 = select CKIN1 • 1 = select CKIN2 |
| Si5324_C_out_fsel | 4 | In | Selects the output frequency of Si5324 C. See Table 3 . |
| Si5324_C_in_fsel | 5 | In | Specifies the input frequency of the reference clock provided to Si5324 C. See Table 3 . |
| Si5324_C_bw_sel | 4 | In | Selects the bandwidth of the Si5324 C. Only legal Si5324 bandwidth settings can be used. The legal settings vary based on the Si5324_out_fsel and Si5324_in_fsel settings. Consult the Si5324 Bandwidth Settings.htm file included with the reference design files to determine the correct value. |
| Si5324_C_DHOLD | 1 | In | Driving this port High places the Si5324 C in digital holdover mode. For normal operation, this input must be Low. |
| Si5324_C_FOS2 | 1 | Out | When High, this indicates a frequency offset error on CKIN2 of Si5324 C. |
| Si5324_C_FOS1 | 1 | Out | When High, this indicates a frequency offset error on CKIN1 of Si5324 C. |
| Si5324_C_LOL | 1 | Out | When High, this indicates that the Si5324 C PLL is not locked to the input reference clock. |

Each clock module can have up to five reference clock inputs and up to five clock outputs, as shown in [Figure 2, page 10](#).

Clock Module GPIO

Each clock module can have a number of general-purpose input and output signals. Some of these are controlled indirectly through the `cm_avb_control` module's GPIO control and status ports. Others are wired directly to FMC connector pins.

Table 7 shows how the 24 GPIO signals and 4 GPIN signals map to signals on the clock module. The direction of each of the 24 GPIO signals is controlled by the `gpio_dir_0`, `gpio_dir_1`, and `gpio_dir_2` ports on the `cm_avb_control` module. Signals programmed as outputs (`gpio_dir` bit = 0), are output from the Spartan-3A FPGA on the FMC card to input pins on the clock module. The values of these outputs are controlled by the `gpio_out_value_0`, `gpio_out_value_1`, and `gpio_out_value_2` ports on the `cm_avb_control` module. Signals programmed as inputs (`gpio_dir` bit = 1) are output from the clock module and input to the Spartan-3A FPGA on the FMC card. The status of each of these signals is periodically updated on the `gpio_in_value_0`, `gpio_in_value_1`, and `gpio_in_value_2` ports of the `cm_avb_control` module. There are four additional signals that are always outputs from the control module and wired to inputs of the Spartan-3A FPGA on the FMC card. The status of each of these four signals is periodically updated on the `gp_in` port of the `cm_avb_control` module.

Table 7: Clock Module GPIO and GPIN Signals

| GPIO/GPIN Signal | Clock Module Pin | Use on CTSLCM1 |
|------------------------|------------------|-----------------|
| GPIO 0 | J1-27 (CM_D_1) | |
| GPIO 1 | J1-31 (CM_D_2) | |
| GPIO 2 | J1-33 (CM_D_3) | |
| GPIO 3 | J1-37 (CM_D_4) | |
| GPIO 4 | J1-39 (CM_D_5) | |
| GPIO 5 | J1-14 (CM_D_6) | |
| GPIO 6 | J1-16 (CM_D_7) | |
| GPIO 7 | J1-20 (CM_D_8) | |
| GPIO 8 | J1-28 (CM_D_11) | |
| GPIO 9 | J1-32 (CM_D_12) | |
| GPIO 10 | J1-34 (CM_D_13) | |
| GPIO 11 | J1-38 (CM_D_14) | |
| GPIO 12 | J1-40 (CM_D_15) | |
| GPIO 13 ⁽¹⁾ | J2-25 (CM_D_16) | Si5324 C CKOUT2 |
| GPIO 14 | J2-27 (CM_D_17) | |
| GPIO 15 | J2-31 (CM_D_18) | |
| GPIO 16 | J2-33 (CM_D_19) | |
| GPIO 17 | J2-37 (CM_D_20) | Si5324 A RST# |
| GPIO 18 | J2-39 (CM_D_21) | Si5324 A INT |
| GPIO 19 | J2-14 (CM_D_22) | |
| GPIO 20 | J2-16 (CM_D_23) | Si5324 B RST# |

Table 7: Clock Module GPIO and GPIN Signals (Cont'd)

| GPIO/GPIN Signal | Clock Module Pin | Use on CTSLCM1 |
|------------------|------------------|----------------|
| GPIO 21 | J2-20 (CM_D_24) | Si5324 B INT |
| GPIO 22 | J2-28 (CM_D_27) | Si5324 C RST# |
| GPIO 23 | J2-40 (CM_D_31) | Si5324 C INT |
| GPIN 0 | J2-22 (CM_D_25) | |
| GPIN 1 | J2-26 (CM_D_26) | |
| GPIN 2 | J2-34 (CM_D_29) | |
| GPIN 3 | J2-38 (CM_D_30) | |

Notes:

- GPIO 13 is dual use. It can be either a general-purpose I/O signal, or it can be the fifth clock output of the clock module. On the CTSLCM1 module, it is the fifth clock output. If used on older clock modules, it is a general-purpose I/O signal. When the CTSLCM1 module is used, this GPIO signal must never be programmed as an output. The clock signal on this pin on the CTSLCM1 is available on the LA24_P/N FMC pins for clock module L and on the HA00_P/N_CC FMC pins for clock module H.
- In addition, clock module pin J1-26 is reserved on most modules for the I²C bus SCL signal and J1-22 for the I²C bus SDA signal. These signals are controlled by the I²C controller located in the Spartan-3A FPGA on the FMC card. These two clock module pins cannot be controlled directly by the carrier board.

Clock Module Clock Signals

Table 8 shows how the five reference clock inputs and five clock outputs of the each clock module are connected.

Table 8: Clock Module Clock Signals

| Clock Module Signal | Clock Module L Connection | Clock Module H Connection | Use on CTSLCM1 |
|----------------------------|------------------------------|------------------------------|-----------------|
| Clock In 1 | FMC LA03_P/N | FMC HA04_P/N | Si5324 C CKIN2 |
| Clock In 2 | FMC LA08_P/N | FMC HA08_P/N | Si5324 A CKIN2 |
| Clock In 3 | FMC LA16_P/N | FMC HA12_P/N | Si5324 B CKIN2 |
| Clock In 4 | Clock Crossbar 1, Output 3 | Clock Crossbar 2, Output 3 | Si5324 C CKIN1 |
| Clock In 5 | Clock Mux in Spartan-3A FPGA | Clock Mux in Spartan-3A FPGA | Si5324 A CKIN1 |
| Clock Out 1 | Clock Crossbar 1, Input 1 | Clock Crossbar 2, Input 1 | Si5324 B CKOUT1 |
| Clock Out 2 | Clock Crossbar 2, Input 2 | Clock Crossbar 2, Input 2 | Si5324 C CKOUT1 |
| Clock Out 3 | FMC LA01_P/N_CC | Clock Crossbar 2, Input 3 | Si5324 A CKOUT1 |
| Clock Out 4 | FMC CLK0_M2C_P/N | FMC HB00_P/N_CC | Si5324 B CKOUT2 |
| Clock Out 5 ⁽¹⁾ | FMC LA24_P/N | FMC HA00_P/N_CC | Si5324 C CKOUT2 |

Notes:

- GPIO 13 is dual use. It can be either a general-purpose I/O signal, or it can be the fifth clock output of the clock module. On the CTSLCM1 module, it is the fifth clock output. If used on older clock modules, it is a general-purpose I/O signal. When the CTSLCM1 module is used, this GPIO signal must never be programmed as an output. The clock signal on this pin on the CTSLCM1 is available on the LA24_P/N FMC pins for clock module L and on the HA00_P/N_CC FMC pins for clock module H.
- In addition, clock module pin J1-26 is reserved on most modules for the I²C bus SCL signal and J1-22 for the I²C bus SDA signal. These signals are controlled by the I²C controller located in the Spartan-3A FPGA on the FMC card. These two clock module pins cannot be controlled directly by the carrier board.

Clock Module I²C Peek and Poke

The `cm_avb_control` module gives the carrier board FPGA access to any register in any device connected to the I²C bus of the clock module to which it is connected. A set of ports on the `cm_avb_control` module allows the carrier board FPGA to read from or write to any I²C bus location.

To write to a location, the `i2c_reg_rdy` signal must be High, indicating that there are no pending I²C bus peek and poke operations in progress. Then, the I²C device slave address must be specified on the `i2c_slave_adr` port. The address of the register in the device must be specified on the `i2c_reg_adr` port. The data written to the register must be specified on the `i2c_reg_dat_wr` port. After these three ports are set up correctly, the `i2c_reg_wr` port signal must be asserted High for one clock cycle to initiate the poke operation. The `i2c_reg_rdy` output goes Low at the first rising edge of the clock after `i2c_reg_wr` is asserted, and stays Low until the poke operation is completed. When `i2c_reg_rdy` goes High, `i2c_reg_error` is normally Low, but it goes High if the operation receives a negative acknowledge (NACK) on the I²C bus, usually indicating an error condition.

To read a location, the `i2c_reg_rdy` signal must be High. Then, the I²C device slave address must be specified on the `i2c_slave_adr` port. The address of the register in the device must be specified on the `i2c_reg_adr` port. The `i2c_reg_rd` port must be asserted High for one clock cycle to initiate the peek operation. The `i2c_reg_rdy` output goes Low at the next rising edge of the clock after `i2c_reg_rd` is asserted and stays Low until the peek operation is completed. When `i2c_reg_rdy` goes High, the data read from the device is present on the `i2c_reg_dat_rd` port. The `i2c_reg_error` output goes High if the operation received a NACK, usually indicating an error condition.

For debugging purposes, the I²C peek and poke ports of the `cm_avb_control` module can be interfaced to a ChipScope™ analyzer VIO module, allowing manual peek and poke capability for any device connected to the I²C bus.

CTSLCM1 Clock Module

This clock module from Cook Technologies was designed specifically for the FMC card. Older clock modules are compatible with the FMC card, but are smaller. The CTSLCM1 is larger so that it can be securely fastened to the FMC card with four screws.

This clock module has three Silicon Labs Si5324 devices on it. Figure 4 shows a block diagram of this clock module.

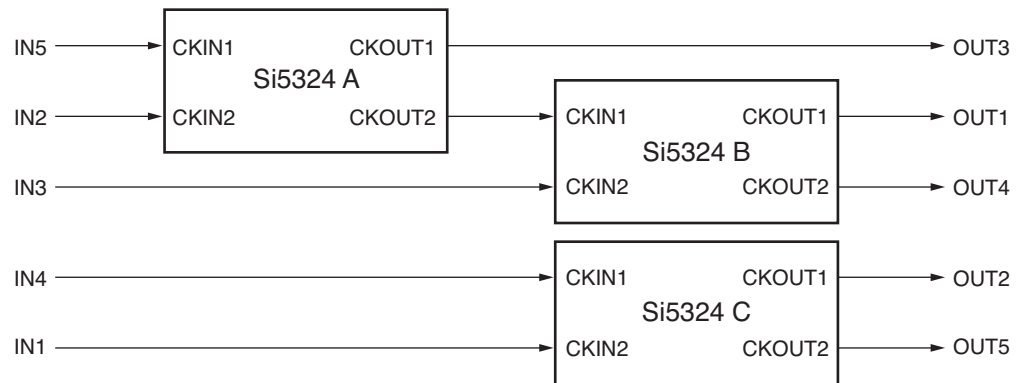

UG753_04_040910

Figure 4: CTSLCM1 Clock Module

There are five reference clock inputs and five output clocks on this clock module. The CKOUT2 output of device Si5324 A is permanently connected to the CKIN1 input of device Si5324 B. This allows these two Si5324 devices to be cascaded when CKIN1 is selected as the reference clock source for the Si5324 B device.

The three Si5324 devices are controlled by an I²C master in the Spartan-3A FPGA on the FMC card, via the I²C bus. The I²C master is implemented in a PicoBlaze™ processor that is pre-programmed to configure the Si5324 devices with a variety of synthesis schemes useful for SDI applications. This is the same set of synthesis schemes available for the Si5324 device located directly on the Si5324 device, and described in [Table 3, page 17](#).

Warranty

THIS LIMITED WARRANTY applies solely to standard hardware development boards and standard hardware programming cables manufactured by or on behalf of Xilinx (“Development Systems”). Subject to the limitations herein, Xilinx warrants that Development Systems, when delivered by Xilinx or its authorized distributor, for ninety (90) days following the delivery date, will be free from defects in material and workmanship and will substantially conform to Xilinx publicly available specifications for such products in effect at the time of delivery. This limited warranty excludes: (i) engineering samples or beta versions of Development Systems (which are provided “AS IS” without warranty); (ii) design defects or errors known as “errata”; (iii) Development Systems procured through unauthorized third parties; and (iv) Development Systems that have been subject to misuse, mishandling, accident, alteration, neglect, unauthorized repair or installation. Furthermore, this limited warranty shall not apply to the use of covered products in an application or environment that is not within Xilinx specifications or in the event of any act, error, neglect or default of Customer. For any breach by Xilinx of this limited warranty, the exclusive remedy of Customer and the sole liability of Xilinx shall be, at the option of Xilinx, to replace or repair the affected products, or to refund to Customer the price of the affected products. The availability of replacement products is subject to product discontinuation policies at Xilinx. Customer may not return product without first obtaining a customer return material authorization (RMA) number from Xilinx.

THE WARRANTIES SET FORTH HEREIN ARE EXCLUSIVE. XILINX DISCLAIMS ALL OTHER WARRANTIES, WHETHER EXPRESS, IMPLIED OR STATUTORY, INCLUDING, WITHOUT LIMITATION, ANY WARRANTY OF MERCHANTABILITY, FITNESS FOR A PARTICULAR PURPOSE, OR NON-INFRINGEMENT, AND ANY WARRANTY THAT MAY ARISE FROM COURSE OF DEALING, COURSE OF PERFORMANCE, OR USAGE OF TRADE. (2008.10)



Do not throw Xilinx products marked with the “crossed out wheeled bin” in the trash. Directive 2002/96/EC on waste electrical and electronic equipment (WEEE) requires the separate collection of WEEE. Your cooperation is essential in ensuring the proper management of WEEE and the protection of the environment and human health from potential effects arising from the presence of hazardous substances in WEEE. Return the marked products to Xilinx for proper disposal. Further information and instructions for free-of-charge return available at: <http://www.xilinx.com/ehs/weee.htm>.

