

LogiCORE IP Reed-Solomon Encoder v8.0

Product Guide

PG025 January 18, 2012

Table of Contents

Chapter 1: Overview

Standards Compliance	4
Licensing	4
Performance	5
Resource Utilization.....	6

Chapter 2: Core Interfaces

Port Descriptions.....	8
------------------------	---

Chapter 3: Customizing and Generating the Core

Parameter Values in the XCO File	15
Output Generation	20
System Generator for DSP Graphical User Interface	20

Chapter 4: Designing with the Core

Functional Description	21
Block Code Settings.....	22

Chapter 5: Detailed Example Design

Demonstration Test Bench	25
--------------------------------	----

Appendix 6: Migrating

Parameter Changes in the XCO File.....	27
Port Changes.....	28

Appendix 7: Additional Resources

Xilinx Resources	29
Solution Centers	29
References	29
Technical Support.....	29
Ordering Information	30
Revision History	30
Notice of Disclaimer	30

Introduction

The Reed-Solomon Encoder is used in many Forward Error Correction (FEC) applications and in systems such as communications systems and disk drives where data is transmitted and subject to errors before reception.

Features

- Implements many different Reed-Solomon coding standards, including all ITU-T J.83 and CCSDS codes
- Automatically configured by user-entered parameters
- Efficiently handles multiple channels
- Fully synchronous design using a single clock
- Supports continuous output data with no gap between code blocks
- Symbol width from 3 bits to 12 bits
- Code block length variable up to 4095 symbols with up to 256 check symbols
- Block length can be changed in real time
- The number of check symbols can be changed in real time
- Supports shortened codes
- Supports any primitive field polynomial for a given symbol width
- User-configured generator polynomial
- AXI4-Stream compliant interfaces
- Use with Xilinx CORE Generator™ software and Xilinx System Generator for DSP 13.4

LogiCORE™ IP Facts Table	
Core Specifics	
Supported Device Family ⁽¹⁾	Zynq™-7000, Artix™-7, Virtex®-7, Kintex™-7, Virtex-6, Spartan®-6
Supported User Interfaces	AXI4-Stream
Resources	See Table 1-1 .
Provided with Core	
Design Files	Netlist
Example Design	Not Provided
Test Bench	VHDL
Constraints File	Not Applicable
Simulation Model	Verilog, VHDL
Supported S/W Driver ⁽²⁾	N/A
Tested Design Tools	
Design Entry Tools	CORE Generator tool 13.4 System Generator for DSP 13.4
Simulation ⁽³⁾	Mentor Graphics ModelSim Cadence Incisive Enterprise Simulator (IES) Synopsys VCS and VCS MX ISim
Synthesis Tools ⁽³⁾	XST 13.4
Support	
Provided by Xilinx @ www.xilinx.com/support	

1. For a complete listing of supported devices, see the [release notes](#) for this core.
2. Standalone driver details can be found in the EDK or SDK directory (<install_directory>/doc/usenglish/xilinx_drivers.htm). Linux OS and driver support information is available from <http://wiki.xilinx.com>.
3. For the supported versions of the tools, see the [ISE Design Suite 13: Release Notes Guide](#).

Overview

Reed-Solomon codes are usually referred to as (n,k) codes, where n is the total number of symbols in a code block and k is the number of information or data symbols. This core generates systematic code blocks where the complete code block is formed from the k information symbols, followed by the $(n-k)$ check symbols. The maximum number of symbol errors in a block that can be guaranteed to be correct is $t = (n-k)/2$. A symbol error can contain any number of bit errors.

Normally $n = 2^{(\text{Symbol_Width})-1}$. If n is less than this, the code is referred to as a “shortened code.” The encoder core handles both full-length and shortened codes.

The parameters n , k , and $(n-k)$ are optionally variable from block to block. The current code block settings for n , k , and $(n-k)$ are referred to as n_block , k_block , and r_block , respectively.

A Reed-Solomon code is also characterized by two polynomials: the field polynomial and the generator polynomial. The field polynomial defines the Galois field, of which the symbols are members. The generator polynomial defines how the check symbols are generated. Both of these polynomials are usually defined in the specification for any particular Reed-Solomon code. The core GUI allows both of these polynomials to be configured.

The core synchronous input control signals are not registered inside the core. It is assumed these are registered external to the core if required.

Standards Compliance

The Reed-Solomon IP core adheres to the AMBA® AXI4-Stream standard.

Licensing

Evaluation

An [evaluation license](#) is available for this core. The evaluation version of the core operates in the same way as the full version for several hours, dependent on clock frequency. Operation is then disabled and the data output does not change. If you notice this behavior in hardware, it probably means you are using an evaluation version of the core. The Xilinx tools warn that an evaluation license is being used during netlist implementation. If a full license is installed for the core to run on hardware, delete the old XCO file and recreate the core from new.

Ordering Information

This Xilinx LogiCORE IP product is provided under the terms of the [SignOnce IP Site License](#). To evaluate this core in hardware, generate an evaluation license, which can be accessed from the Xilinx [IP Evaluation](#) page.

After purchasing the core, you will receive instructions for registering and generating a full core license. The full license can be requested and installed from the Xilinx [IP Center](#) for use with the Xilinx CORE Generator™ software 13.4. The CORE Generator software is bundled with the ISE® Design Suite software 13.4 at no additional charge.

Contact your local Xilinx [sales representative](#) for pricing and availability on Xilinx LogiCORE products and software.

Performance

Latency

For this core, *latency* is defined as the number of rising clock edges from sampling `s_axis_input_tdata` to the sampled value appearing on `m_axis_output_tdata`. The basic latency of the core is (2 + number of channels). For example, the latency in [Figure 1-1](#) is 3.

- Selecting *CCSDS* increases the latency of the encoder by 2.
- Selecting *ITU J.83 Annex B* increases the latency by 1.
- Selecting `m_axis_output_tready` increases the latency by a further 2, but also makes latency variable due to the presence of a FIFO to accommodate backpressure inherent in the AXI4-Stream protocol.

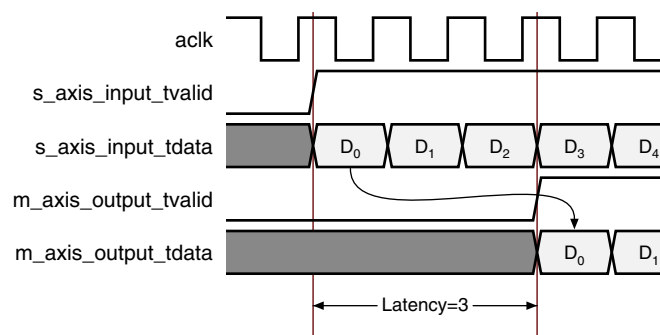

Figure 1-1: Latency

Throughput

The maximum raw data input rate in Mb/s can be calculated as:

$$F_{\max} (\text{MHz}) * \text{Symbol_Width} (\text{bits}) * k/n$$

Resource Utilization

The area of the core increases with $(n-k)$ and `Symbol_Width`. Some example implementations are shown in [Table 1-1](#).

When a variable number of check symbols is not required, the check symbol generator is implemented efficiently as a fixed architecture. When a variable number of check symbols is required, the check symbol generator must be either *optimized for area*, where the implementation area is increased by a factor of approximately 3, or *optimized for flexibility*, where the implementation area is increased by a factor of approximately 5.

The option to map primary I/O registers into IOB flip-flops should be selected if the core I/Os are to be connected directly onto a PCB using the FPGA package pins. This gives lower output clock-to-out times and predictable setup and hold times. Remember the control signal inputs are used unregistered inside the core, so these should be registered external to the core.

Performance Characteristics

In general, performance increases as $n-k$ and `Symbol_Width` decrease. The clock frequencies given in [Table 1-1](#) can be achieved when the corresponding period constraint is specified for the core clock input.

The area and speed values were obtained with map and par effort level set to high. Apart from this, default implementation tools options were used. It might be possible to improve slightly on these values by trying different options for the place and route software.

An implementation where a variable number of check symbols is required results in a lower maximum speed. The cases in [Table 1-1](#) are with `output_tready` enabled. Disabling `output_tready` reduces the LUT and FF counts by approximately twice the `Symbol_Width` and can increase achievable performance.

The cases in [Table 1-1](#) have `marker_bits` disabled. Use of `marker_bits` adds approximately 2 LUTs and 2 FFs per `marker_bit`. The last case ([Var Check Syms](#)) has both variable block length and number of check symbols. The part used in all cases was XC7VX330T-FFG1157. The speedfile used was ADVANCED 1.02c 2011-11-28. This core does not use XtremeDSP™ slices.

[Table 1-1](#) provides resource and performance data for Virtex®-7 FPGAs. For other devices, the user should generate a core and consult a map report to determine device utilization.

Table 1-1: Example Implementations

	DVB 1	DVB 2	ATSC	G.709	ETSI-BRAN	ITU J.83 Annex B	CCSDS	Var Check Syms
Symbol Width	8	8	8	8	8	8	7	8
Generator Start	0	0	0	0	0	112	1	0
h	1	1	1	1	1	11	1	1
k	188	188	187	239	239	223	122	239
n	204	204	207	255	255	255	127 ^[1]	255
Field Polynomial	285	285	285	285	285	391	137	285
Number of Channels	1	16	1	1	1	1	1	1
Variable Block Length	No	No	No	No	Yes	No	No	Yes
LUT/FF Pairs ^[2]	240	390	288	240	290	132	381	848
LUTs ^[3]	226	382	272	225	271	120	362	824
FFs	197	339	229	197	224	117	327	362
Block RAMs (36k)	0	0	0	0	0	0	0	0
Block RAMs (18k)	0	0	0	0	0	0	1	0
Max Clock Freq ^{[2][4]}	405/599	360/517	402/503	388/598	335/441	447/612	230/320	266/402

Notes:

1. There are actually 128 symbols per block, but n is set to 127. The core automatically generates the 128th symbol if the spec is set to J.83 Annex B.
2. Area and max clock frequencies are provided as a guide. They might vary with new releases of the Xilinx implementation tools.
3. LUT count includes route-thrus and might vary when the core is packed with other logic. Resource information is for -1 speed grade.
4. Maximum clock frequencies are shown in MHz for -1/-3 parts. The clock frequency does not take clock jitter into account and should be derated by an amount appropriate to the clock source jitter specification.

Core Interfaces

This chapter provides detailed descriptions for each interface.

Port Descriptions

Pinout

Port names for the core module are shown in Figure 2-1 and described in Table 2-1.

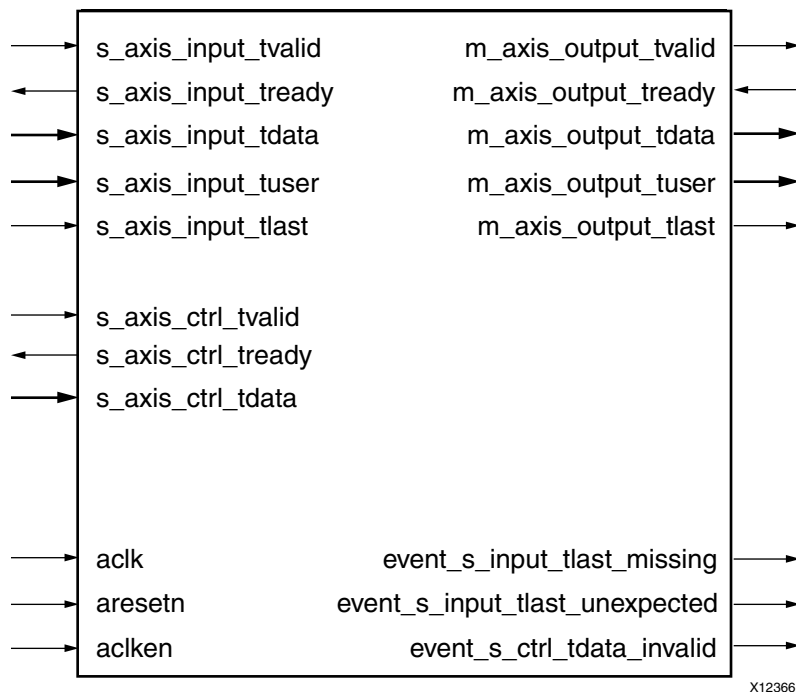

Figure 2-1: Core Schematic Symbol

Table 2-1: Core Signal Pinout

Signal	Direction	Optional	Description
aclk	INPUT	No	Rising edge clock
acken	INPUT	Yes	Active High clock enable
aresetn	INPUT	Yes	Active Low synchronous clear (overrides acken). aresetn must be asserted for at least 2 clock cycles.

Table 2-1: Core Signal Pinout (Cont'd)

Signal	Direction	Optional	Description
s_axis_input_tvalid	INPUT	No	TVALID for S_AXIS_INPUT channel. See AXI4-Stream Protocol for protocol.
s_axis_input_tready	OUTPUT	No	TREADY for S_AXIS_INPUT
s_axis_input_tdata	INPUT	No	Input data and erase flag, if applicable
s_axis_input_tuser	INPUT	Yes	User bits, passed through core unmodified, with same latency as s_axis_input_tdata
s_axis_input_tlast	INPUT	No	Marks last symbol of input block. Only used to generate event outputs. Can be tied Low or High if event outputs not used.
s_axis_ctrl_tvalid	INPUT	Yes	TVALID for S_AXIS_CTRL channel. This channel is only present if core has variable block length or number of check symbols
s_axis_ctrl_tready	OUTPUT	Yes	TREADY for s_axis_ctrl_channel
s_axis_ctrl_tdata	INPUT	Yes	Block length and number of check symbols, if applicable
m_axis_output_tvalid	OUTPUT	No	TVALID for M_AXIS_OUTPUT channel
m_axis_output_tready	INPUT	Yes	TREADY for M_AXIS_OUTPUT channel. Tie High if downstream slave is always able to accept data from M_AXIS_OUTPUT
m_axis_output_tdata	OUTPUT	No	Corrected data output
m_axis_output_tuser	OUTPUT	Yes	s_axis_input_tuser delayed by core latency
m_axis_output_tlast	OUTPUT	No	High when last symbol of last channel is on m_axis_output_tdata
event_s_input_tlast_missing	OUTPUT	No	Flags that s_axis_input_tlast was not asserted when expected. Leave unconnected if not required.
event_s_input_tlast_unexpected	OUTPUT	No	Flags that s_axis_input_tlast was asserted when not expected. Leave unconnected if not required.
event_s_ctrl_tdata_invalid	OUTPUT	No	Flags that values provided on s_axis_ctrl_tdata were illegal. Core must be reset if this is asserted. Leave unconnected if not required.

aclken

The clock enable input (`aclken`) is an optional pin. When `aclken` is deasserted (low), all the other synchronous inputs are ignored, except `aresetn`, and the core remains in its current state. This pin should be used only if it is genuinely required because it has a high fan out within the core and can result in lower performance.

`aclken` is a *true* clock enable and causes the entire core to freeze state when it is low.

An example of `aclken` operation is shown in [Figure 2-2](#). In this case, the core ignores symbol `D4` as input to the block, and the current `m_axis_output_tdata` value remains unchanged. (The decoder still samples *n* symbols.) As `D4` is not included in the code block, the output sequence ...`D0,D1,D2,D3,D5`... appears on `m_axis_output_tdata` during the output stage of this block.

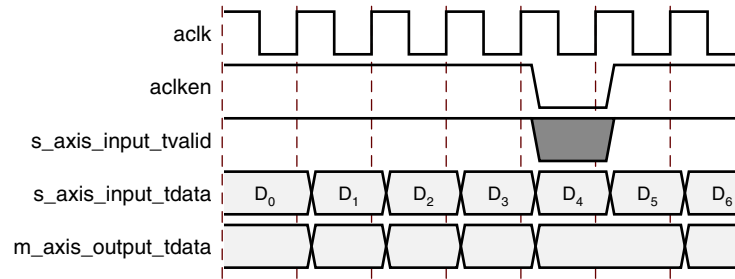

Figure 2-2: Clock Enable Timing

aresetn

The synchronous reset (`aresetn`) input is an optional pin. It can be used to re-initialize the core at any time, regardless of the state of `aclken`. `aresetn` needs to be asserted low for at least two clock cycles to initialize the circuit. The core becomes ready for normal operation two cycles after `aresetn` goes high. This pin should be selected with caution, as it increases the size of the core and can reduce performance.

The timing for the `aresetn` input is illustrated in Figure 2-3. Note that some outputs are not reset by `aresetn`.

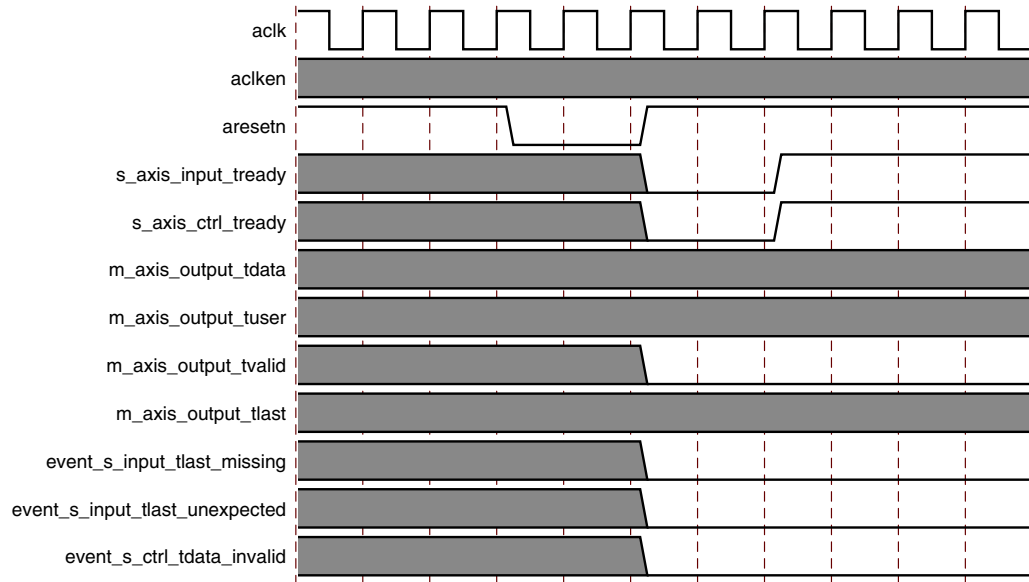

Figure 2-3: Synchronous Reset Timing

S_AXIS_INPUT Channel

s_axis_input_tdata

Data to be processed is passed into the core on this port. To ease interoperability with byte-oriented buses, TDATA is padded with zeros, if necessary, to fit a bit field which is a multiple of 8 bits. The padding bits are ignored by the core and do not result in additional resource use. The structure is shown in Figure 2-4.

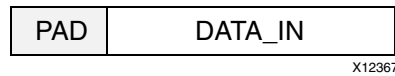

Figure 2-4: Input Channel TDATA Structure

DATA_IN Field

This is the input bus for the incoming uncoded data. The width of the DATA_IN portion of the field is set by the Symbol Width parameter in the GUI.

s_axis_input_tuser

This optional input is used to pass information through the core with exactly the same latency as s_axis_input_tdata. This could be used to tag each symbol sampled on DATA_IN with marker bits, for example. The number of TUSER bits is parameterizable and set by the Number of Marker Bits parameter in the GUI. The TUSER bits are delayed with the same latency as DATA_IN to DATA_OUT and output on m_axis_output_tuser. For example, if “5” is sampled on s_axis_input_tuser at the same time as the first symbol on s_axis_input_tdata, then “5” is output on m_axis_output_tuser at the same time the first symbol is output on m_axis_output_tdata.

This feature can be used to mark special symbols within a frame or to tag data from different blocks with block identification numbers.

s_axis_input_tlast

This input can be tied low or high if the event outputs (event_s_input_tlast_missing and event_s_input_tlast_unexpected) are not used. It is present purely to provide a check that the system and core are in sync with block sizes. If the event outputs are used then s_axis_input_tlast must be asserted high when the last symbol of a block is sampled on s_axis_input_tdata. In the multichannel case it must be asserted when the last symbol of the last channel of the block is sampled on s_axis_input_tdata. The core maintains its own internal count of the symbols, so it knows when the last symbol is being sampled. If s_axis_input_tlast is not sampled high when the last input symbol is sampled then event_s_input_tlast_missing is asserted until the next input sample is taken. Similarly, if s_axis_input_tlast is sampled high when the core is not expecting it, event_s_input_tlast_unexpected is asserted until the next input sample is taken. If either of these events occurs then the system and the core are out of sync and the core, and possibly the system, should be reset.

S_AXIS_CTRL Channel

s_axis_ctrl_tdata

If the S_AXIS_CTRL channel is present, control data for each block is passed into the core on this port. The port is composed of a number of subfields, depending on parameter settings. Each subfield is padded to make it a multiple of 8 bits. The padding bits are ignored by the core and do not result in additional resource use. The structure is shown in Figure 2-5. Care should be taken to ensure only valid combinations of N_IN and R_IN are provided, as the core might need to be reset if invalid values are written.

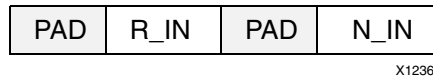

Figure 2-5: Control Channel TDATA Structure

N_IN Field

This field is only present if “Variable Block Length” is selected in the GUI. This allows the block length to be changed every block. Unless there is an R_IN field, the number of check symbols is fixed, so varying n automatically varies k .

For example, if N_IN is set to 255 and R_IN is set to 16 in the control word C_1 in Figure 2-7, the next input block (starting D_1) is treated as a ($n=255, k=239$) codeword. If C_2 has N_IN equal to 64 and R_IN is equal to 8, then the next input block (starting D_N) is treated as a ($n=64, k=56$) codeword. For this example, n should be set to 255 and k to 239 in the GUI, as the largest expected R_IN value is 16. This would give an R_IN field width of 5 bits (plus 3 padding bits).

R_IN Field

This field is only present if “Variable Number of Check Symbols” is selected in the GUI. It allows the number of check symbols to be changed every block. Selecting this input significantly increases the size of the core.

The width of the R_IN field is the minimum number of bits required to represent the maximum n value minus the minimum k value, padded with unused inputs to round up to the nearest multiple of 8.

M_AXIS_OUTPUT Channel

m_axis_output_tdata

Uncoded data sampled on `s_axis_input_tdata` is encoded and output from the core on this port. The port is composed of a number of subfields, depending on parameter settings. All output fields are padded with zeroes to fit a bit field which is a multiple of 8 bits. The structure is shown in Figure 2-6.

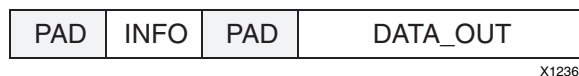

Figure 2-6: Output Channel TDATA Structure

DATA_OUT Field

This is the output field for the corrected symbols. This field always has the same width as DATA_IN.

Corrected symbols start to appear a number of clock cycles after the first symbol is sampled on DATA_IN. This delay is termed the latency of the decoder and is explained in

[Latency, page 5](#). Latency can vary if the block size is dynamically varied with the N_IN field or if the output is stalled by deassertion of a TREADY input.

INFO Field

This optional output field contains a single information bit, INFO, which is high when data symbols are on DATA_OUT and low when check symbols are on DATA_OUT (that is, the last $n-k$ symbols of the block).

m_axis_output_tuser

This optional output is s_axis_input_tuser delayed by the same latency as s_axis_input_tdata to m_axis_output_tdata. The width is the same as s_axis_input_tuser. As only k values are sampled on the input, only k values can be output.

m_axis_output_tlast

This output is High when the last symbol of a block is on m_axis_output_tdata (the n th symbol). In the multichannel case, m_axis_output_tlast is only asserted High when the last symbol of the last channel is present on m_axis_output_tdata. This is shown in [Figure 2-8](#).

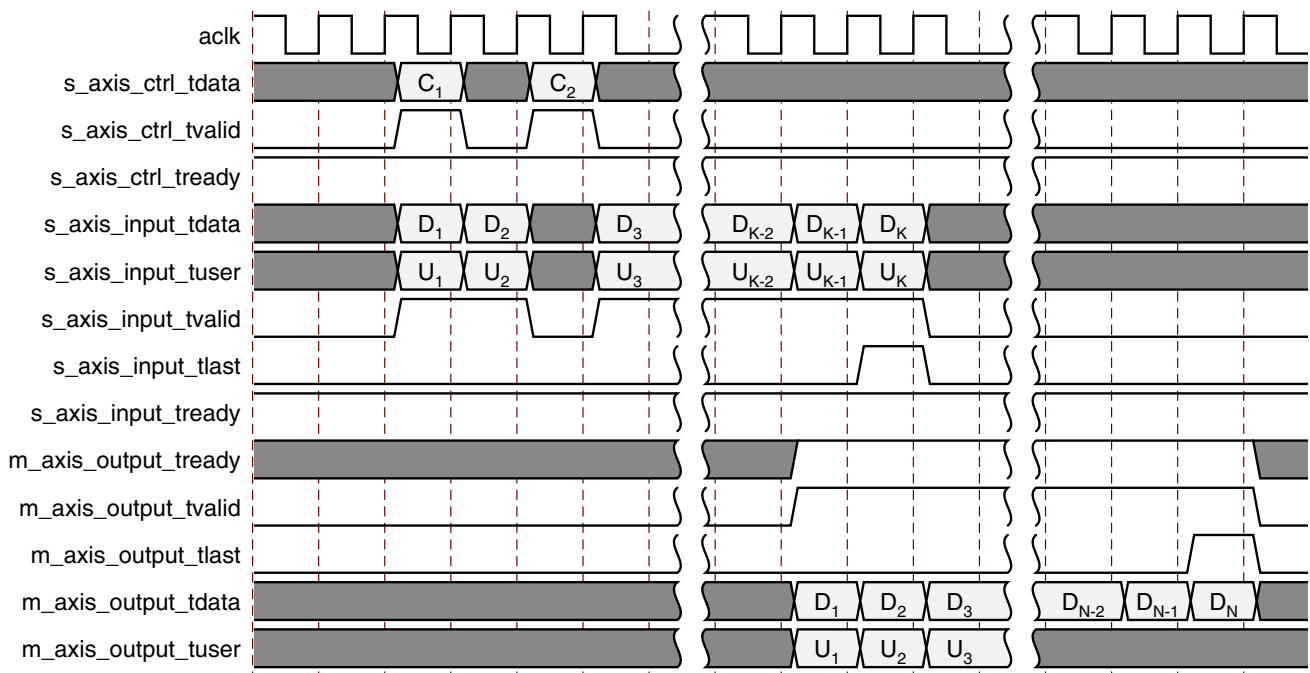

Figure 2-7: Block Input to Output Timing

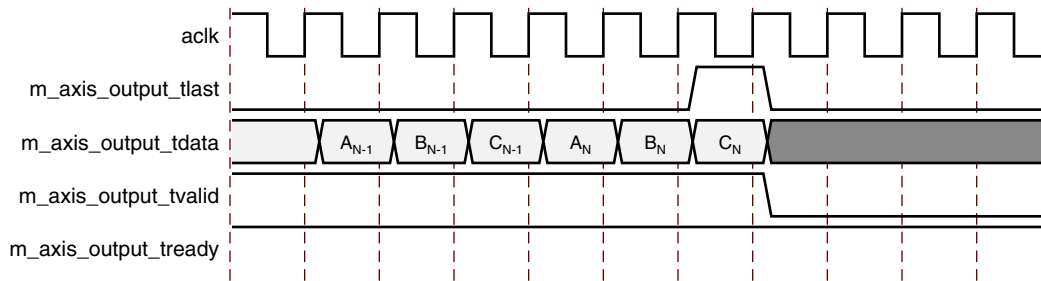

Figure 2-8: TLAST Output Timing for 3 Channel Example

event_s_input_tlast_missing

This output is asserted high if `s_axis_input_tlast` is not sampled high when the last symbol of a block is sampled. It should be left unconnected if not required and the logic used to generate it is optimized away. This output is only asserted until the next input sample starts to be processed inside the core, so care must be taken not to miss a pulse on this output. This output can be used to interrupt the system and possibly instigate a reset sequence.

event_s_input_tlast_unexpected

This output is asserted high if `s_axis_input_tlast` is sampled high when an input symbol that is not the last symbol of a block is sampled. Its timing and operation are the same as `event_s_input_tlast_missing`.

event_s_ctrl_tdata_invalid

This output is asserted high if the core has an `S_AXIS_CTRL` channel and values are sampled on `N_IN` or `R_IN` that are outside the absolute limits the core can handle. The limits are computed at core generation time, based on the parameters selected. When asserted, this output remains asserted until the core is reset. The core must be reset if this output is asserted, as invalid `N_IN` or `R_IN` values can cause the core to malfunction for subsequent blocks and not recover. Control values should be within the limits defined in [Table 3-1](#).

Customizing and Generating the Core

This chapter includes information on using Xilinx tools to customize and generate the core.

Parameter Values in the XCO File

The core GUI provides a number of parameter values for several common Reed-Solomon standards. It also allows the user to define the following parameters:

Table 3-1: Parameter Values

GUI Name	Default Value	Valid Range	XCO Parameter
Component Name	rs_encoder_v8_0		Component_Name
Code Specification	Custom	Custom, DVB, ATSC, G_709, ETSI_BRAN, CCSDS, ITU_J_83_Annex_B, IESS_308_126, IESS_308_194, IESS_308_208, IESS_308_219, IESS_308_225	
Variable Number of Check Symbols	false	false, true	Variable_Number_Of_Check_Symbols
Variable Block Length	false	false, true	Variable_Block_Length
Symbol Width	8	3 to 12	Symbol_Width
Field Polynomial	0	0 to 8191	Field_Polynomial
Scaling Factor (h)	1	1 to 65535	Scaling_Factor
Generator Start	0	0 to 1023	Generator_Start
Symbols Per Block (n)	255	4 to $2^{\text{Symbol_Width}-1}$	Symbol_Per_Block
Data Symbols (k)	239	2 to $2^{\text{Symbol_Width}-3}$ $2 < n-k < 256$	Data_Symbols
Check Symbol Generator Optimization	Fixed_Architecture	Fixed_Architecture, Optimized_For_Area, Optimized_For_Flexibility	Check_Symbol_Generator
Memory Style	Automatic	Automatic, Block, Distributed	Memory_Style

Table 3-1: Parameter Values (Cont'd)

GUI Name	Default Value	Valid Range	XCO Parameter
Number Of Channels	1	1 to 128	Number_Of_Channels
Clock Enable	false	false, true	aclken
Synchronous Reset	false	false, true	aresetn
m_axis_output_tready	false	false, true	m_axis_output_tready
Info bit	false	false, true	info
Marker Bits	false	false, true	Marker_Bits
Number Of Marker Bits	1	1 to 16	Number_Of_Marker_Bits

Notes:

1. Parameter valid ranges are adjusted in the GUI to be consistent with other parameter settings.

Code Specification

The GUI aids creation of cores for a number of common Reed-Solomon specifications. After a particular specification has been chosen, the GUI automatically selects the values necessary to meet the specification.

Most of the standards listed just result in particular values being set and then greyed out for most of the parameters in the GUI. However, some of the standards result in additional logic being added to the core. These are described in the following sections.

CCSDS

When implementing the CCSDS specification, the core automatically implements the dual-basis conversions defined in the CCSDS specification. This is illustrated in Figure 3-1. If the dual-basis conversions are not required, select *custom* specification instead of CCSDS and enter all the code parameters manually. Selecting CCSDS increases the latency of the encoder by 2.

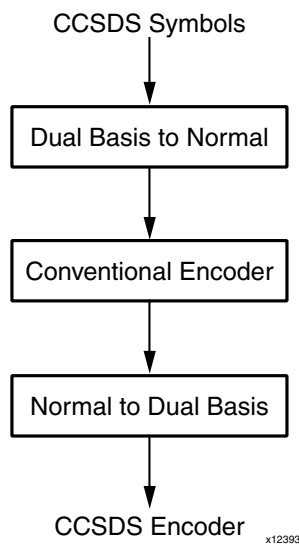

Figure 3-1: CCSDS Encoder

ITU J.83 Annex B

This standard is unusual in that it calls for a (128,122) code. This suggests that n is greater than $2^{(\text{Symbol_Width})-1}$, as the Symbol Width is only 7 bits. However, the standard specifies that the first 127 symbols are generated as a normal RS code. A special 128th symbol is then appended to the end of the block. If *ITU J.83 Annex B* is selected, then the core includes the logic required to generate this 128th symbol.

Selecting *ITU J.83 Annex B* increases the latency of the encoder by 1. The other RS codes specified in the ITU J.83 standard do not require this additional symbol, and the *custom* code specification should be selected for them.

Variable Number of Check Symbols

The `R_IN` field is added when a variable number of check symbols is required.

- Whenever a block is started, the new number of check symbols, r_block , is read from the internal CTRL data FIFO.
- The number of check symbols in the new block is independent of the block length, so varying `R_IN` also changes the number of data symbols in the block, k_block , by negative the same amount.
- The n parameter must be set to $2^{(\text{Symbol_Width})-1}$. The k parameter should be set such that $(n-k)$ equals the maximum number of check symbols required. The width of `R_IN` port is the number of bits required to represent $(n-k)$ in unsigned binary format.
- A multichannel implementation is not available if a variable number of check symbols is required.
- The value sampled on `R_IN` must be in the range given for r_block in [Table 4-1](#).

For full details on the variable block code settings k_block and r_block , see [Block Code Settings](#), page 22.

Variable Block Length

The `N_IN` field is added when a variable block length is required.

- Whenever a block is started, the new block length, n_block , is read from the internal CTRL data FIFO.
- The number of check symbols in the new block is independent of the block length, so varying n_block also changes the block's number of data symbols, k_block , by the same amount.
- The n parameter must be set to $2^{(\text{Symbol_Width})-1}$, and the k parameter should be set such that $(n-k)$ equals the number of check symbols required.
- For multichannel implementations, n_block is the same for all channels.
- The value sampled on `N_IN` must be in the range given for n_block in [Table 4-1](#).

For full details on the variable block code settings n_block and k_block , see [Block Code Settings](#), page 22.

Symbol Width

This is the width of the `N_IN`, `DATA_IN` and `DATA_OUT` fields.

Field Polynomial

This is used to generate the Galois field for the code. It is entered as a decimal number where the bits of the binary equivalent correspond to the polynomial coefficients. For example,

$$x^8 + x^4 + x^3 + x^2 + 1 \Rightarrow 100011101 \Rightarrow 285$$

A value of zero causes the default polynomial for the given Symbol Width to be selected. If Field Polynomial is not primitive, the core GUI highlights it in red. Table 3-2 shows the default field polynomial.

Table 3-2: Default Polynomials

Symbol Width	Default Polynomial	Decimal Representation
3	x^3+x+1	11
4	x^4+x+1	19
5	x^5+x^2+1	37
6	x^6+x+1	67
7	x^7+x^3+1	137
8	$x^8+x^4+x^3+x^2+1$	285
9	x^9+x^4+1	529
10	$x^{10}+x^3+1$	1033
11	$x^{11}+x^2+1$	2053
12	$x^{12}+x^6+x^4+x+1$	4179

Scaling Factor (h)

The scaling factor for the generator polynomial root index. Normally, h is 1.

To ensure correct operation of the Reed-Solomon decoder, the value of h must be chosen so that the greatest common divisor of h and $2^{(Symbol_Width)}-1$ is 1, that is, h and $2^{(Symbol_Width)}-1$ must be relative primes.

GeneratorStart

This is the Galois field logarithm of the first root of the generator polynomial.

Normally, GeneratorStart is 0 or 1; however, it can be any positive integer up to 1023.

$$g(x) = \prod_{i=0}^{n-k-1} (x - \alpha^{h \times (GeneratorStart + i)})$$

Symbols per Block (n)

The number of symbols in a fixed length code block. If this is a shortened code, n should be the shortened number.

When a variable block length is required, the n parameter is defaulted to $2^{(\text{Symbol_Width})-1}$ and the block length, n_block , is set to the value sampled on the N_IN field.

Data symbols (k)

The number of information or data symbols in a fixed length code block.

When a variable block length and a fixed number of check symbols are required, the block's number of data symbols, k_block , is set to the value sampled on N_IN minus parameter $(n-k)$.

When a variable number of check symbols is required, the block's number of data symbols, k_block , is set to the value sampled on N_IN minus the value sampled on the R_IN field.

Check Symbol Generator Optimization

If a variable number of check symbols is not required, then Check Symbol Generator Optimization must be set to *Fixed Architecture*.

- *Fixed Architecture* – The check symbol generator is implemented using a highly efficient fixed architecture.

If a variable number of check symbols is required, the Check Symbol Generator Optimization must be set to one of the following:

- *Optimized for Flexibility* – The check symbol generator implementation is optimized to maximize the range of input field, N_IN .
- *Optimized for Area* – The check symbol generator implementation is optimized for area and speed efficiency. The range of input field, N_IN , is reduced.

Memory Style

If the target device architecture supports block memory, the following options are available:

- *Distributed* – Core should not use any block memories if possible. This is useful if they are required elsewhere in the design.
- *Block* – Core should use block memories wherever possible. This keeps the number of CLBs used to a minimum, but might use block memory wastefully.
- *Automatic* – This allows the core to use the most appropriate style of memory for each case, based on required memory depth.

Number of Channels

The core can process multiple input channels simultaneously with only a small increase in area. This is much more efficient than instantiating multiple RS Encoder cores.

When a new block is started for one channel, a new block is started for all the other channels as well. The code settings n_block , k_block and r_block are the same for all channels. The multichannel configuration is not available when a variable number of check symbols is required.

The latency is increased by 1 for each additional channel.

With multiple channels, there is still only one DATA_IN port. Incoming symbols for the channels are interlaced so the core samples the first symbol of channel 1 on the first rising clock edge, then the first symbol of channel 2 on the second rising clock edge, and so on. Symbols (both information and check) are output on DATA_OUT in the same sequence. An example with three channels is shown in Figure 3-2.

A new block is started for all three channels when `s_axis_input_tvalid` is asserted. A1, B1 and C1 are the first symbols of the new block for channels A, B and C. `s_axis_input_tvalid` can be deasserted at any time. For example, no value is sampled at the start of clock cycle 8.

Symbols on `m_axis_output_tdata` are interlaced in the same way as symbols on `s_axis_input_tdata`.

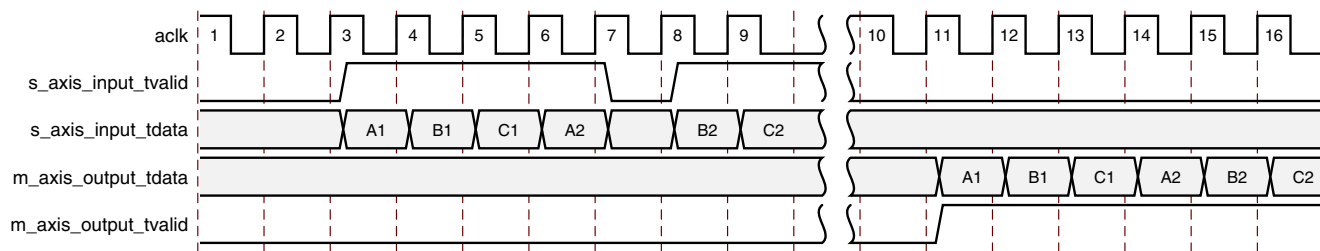

Figure 3-2: Multi-Channel Operation

Output Generation

Several files are produced when a core is generated, and customized instantiation templates for Verilog and VHDL design flows are provided in the `.veo` and `.vho` files, respectively. For detailed instructions, see the CORE Generator™ software documentation.

System Generator for DSP Graphical User Interface

The Reed-Solomon Encoder core is available through Xilinx System Generator for DSP, a design tool that enables the use of the model-based design environment Simulink® for FPGA design. The Reed-Solomon Encoder core is one of the DSP building blocks provided in the Xilinx blockset for Simulink. The core can be found in the Xilinx Blockset in the Communication section. The block is called “Reed-Solomon Encoder 8.0.” See the System Generator User Manual for more information.

The controls in the System Generator GUI work identically to those in the CORE Generator GUI. See [Parameter Values in the XCO File, page 15](#), for detailed information about all other parameters.

Designing with the Core

This chapter includes guidelines and additional information to make designing with the core easier.

Functional Description

AXI4-Stream Protocol

The use of AXI4-Stream interfaces brings standardization and enhances interoperability of Xilinx IP LogiCORE™ solutions. Other than general control signals such as `ac1k`, `ac1ken` and `aresetn`, and event outputs, all inputs and outputs to the core are conveyed using AXI4-Stream channels. A channel consists of TVALID and TDATA always, plus several optional ports and fields. In the RS Encoder core, the additional ports used are TREADY, TLAST and TUSER. Together, TVALID and TREADY perform a handshake to transfer a value, where the payload is TDATA, TUSER and TLAST. The payload is indeterminate when TVALID is deasserted.

The RS Encoder core operates on the values contained in the S_AXIS_INPUT channel TDATA fields and outputs the results in the TDATA fields of the M_AXIS_OUTPUT channel. The RS Encoder core does not use inputs TUSER and TLAST as such, but the core provides the facility to convey TUSER with the same latency as TDATA. This facility of passing TUSER from input to output is intended to ease use of the core in a system. TLAST is provided purely as a check that the core is in sync with the system and its use is optional.

For further details on AXI4-Stream Interfaces see [\[Ref 1\]](#) and [\[Ref 2\]](#).

Basic Handshake

[Figure 4-1](#) shows the transfer of data in an AXI4-Stream channel. TVALID is driven by the source (master) side of the channel and TREADY is driven by the receiver (slave). TVALID indicates that the value in the payload fields (TDATA, TUSER and TLAST) is valid. TREADY indicates that the slave is ready to receive data. When both TVALID and TREADY are true in a cycle, a transfer occurs. The master and slave set TVALID and TREADY respectively for the next transfer appropriately.

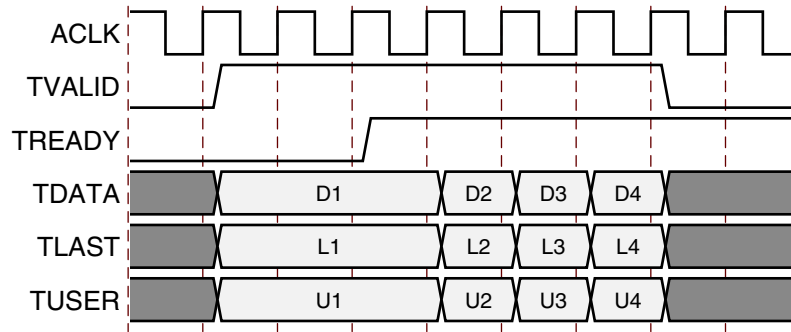

Figure 4-1: Data Transfer in an AXI-Stream Channel

The full flow control of AXI4-Stream aids system design because the flow of data is self-regulating. Data loss is prevented by the presence of back pressure (TREADY), so that data is only propagated when the downstream datapath is ready to process it.

The core has two input channels: S_AXIS_INPUT and S_AXIS_CTRL. If any of the block parameters, such as block length, have been selected to be run time configurable then a block cannot be processed until the control values for that block have been loaded on S_AXIS_CTRL. A new control value must be loaded for every new block or the core will stall the S_AXIS_INPUT channel by deasserting `s_axis_input_tready`. Some data can be input without a control value until the input FIFO fills. It is recommended to write control values before the data is supplied. To guarantee that the input channel is not stalled due to lack of control information, the control value should be written no later than one clock cycle before the first data symbol is sampled. Control values are stored in a FIFO inside the core and used when a new input block is started. Up to 16 control values can be stored before any input data is provided. After the control FIFO fills, `s_axis_ctrl_tready` is deasserted.

The core has one output channel: M_AXIS_OUTPUT. If the output is prevented from off-loading data because `m_axis_output_tready` is low then data accumulates in the core. When the core's internal buffers are full the core stops further operations. This prevents the input buffers from off-loading data for new operations so the input buffers fill as new data is input. When the input buffers fill, their respective TREADYs (`s_axis_input_tready` and `s_axis_ctrl_tready`) are deasserted to prevent further input. This is the normal action of back pressure.

Block Code Settings

The RS Encoder generates a systematic (n_block, k_block) block code, where the output block is n_block symbols long, comprised from k_block data symbols followed by r_block check symbols. The block code settings n_block , k_block and r_block are optionally variable on a block-by-block basis. For multichannel configurations, all channels have the same settings for n_block , k_block and r_block . See [Table 4-1](#).

Table 4-1: Block Code Settings – Value and Range

Block Code Settings	Value	Range Min	Range Max
Fixed Block Length			
<i>n_block</i>	<i>n</i>	4	$2^{(\text{Symbol_Width})-1}$
<i>k_block</i>	<i>k</i>	2	$2^{(\text{Symbol_Width})-3}$
<i>r_block</i>	$(n-k)$	2	$\min(n-k, 256)$
Variable Block Length. Fixed Number of Check Symbols			
<i>n_block</i>	N_IN	4	$2^{(\text{Symbol_Width})-1}$
<i>k_block</i>	$N_IN - (n-k)$	2	$2^{(\text{Symbol_Width})-3}$
<i>r_block</i>	$(n-k)$	2	$\min(n-k, 256)$
Variable Number of Check Symbols (optimized for flexibility)			
<i>n_block</i>	N_IN	5	$2^{(\text{Symbol_Width})-1}$
<i>k_block</i>	$N_IN - R_IN$	3	$2^{(\text{Symbol_Width})-3}$
<i>r_block</i>	R_IN	2	$\min(n-k, 128)$
Variable Number of Check Symbols (optimized for area)			
<i>n_block</i>	N_IN	$2^{*(n-k)}$	$2^{(\text{Symbol_Width})-1}$
<i>k_block</i>	$N_IN - R_IN$	3	$2^{(\text{Symbol_Width})-3}$
<i>r_block</i>	R_IN	2	$\min(n-k, 128)$

n_block

The block code setting *n_block* specifies the total number of symbols in the current code block.

- When a variable block length is not required, *n_block* is set to the parameter *n* for every code block.
- When a variable block length is required, *n_block* is set to the value written for the current block on the CTRL channel N_IN field.

k_block

The block code setting *k_block* specifies the number of data symbols in the current code block.

- When a variable block length is not required, *k_block* is set to the parameter *k* for every block.
- When a variable block length is required and a variable number of check symbols is not required, *k_block* is set to the value written for the current block on the CTRL channel N_IN field minus the parameter $(n-k)$.
- When a variable number of check symbols is required, *k_block* is set to the value written for the current block on the CTRL channel N_IN field minus the value sampled on R_IN.

r_block

The block code setting *r_block* specifies the number of check symbols in the current code block.

- When a variable number of check symbols is not required, *r_block* is set to parameter $(n-k)$ for every block.
- When a variable number of check symbols is required, *r_block* is set to the value written for the current block on the CTRL channel R_{IN} field.

Detailed Example Design

Demonstration Test Bench

When the core is generated using CORE Generator™, a demonstration test bench is created. This is a simple VHDL test bench that exercises the core.

The demonstration test bench source code is one VHDL file: `<component_name>/demo_tb/tb_<component_name>.vhd` in the CORE Generator output directory. The source code is comprehensively commented.

Using the Demonstration Test Bench

The demonstration test bench instantiates the generated RS Encoder core. Either the behavioral model or the netlist can be simulated within the demonstration test bench.

- Behavioral model: Ensure that the CORE Generator project options are set to generate a behavioral model. After generation, this creates a behavioral model wrapper named `<component_name>.vhd`. Compile this file into the work library (see your simulator documentation for more information on how to do this).
- Netlist: If the CORE Generator project options were set to generate a structural model, a VHDL or Verilog netlist named `<component_name>.vhd` or `<component_name>.v` was generated. If this option was not set, generate a netlist using the netgen program, for example:

```
netgen -sim -ofmt vhdl <component_name>.ngc
<component_name>_netlist.vhd
```

Compile the netlist into the work library (see your simulator documentation for more information on how to do this). Then compile and simulate the demonstration test bench. View the test bench's signals in your simulator's waveform viewer to see the operations of the test bench.

The Demonstration Test Bench in Detail

The demonstration test bench performs the following tasks:

- Instantiates the core
- Generates an input codeblock consisting of a sinusoid
- Generates a clock signal
- Drives the core's input signals to demonstrate core features
- Checks that the core's output signals obey AXI protocol rules (data values are not checked in order to keep the test bench simple)

- Provides signals showing the separate fields of AXI TDATA and TUSER signals

The demonstration test bench drives the core input signals to demonstrate the features and modes of operation of the core. The operations performed by the demonstration test bench are appropriate for the configuration of the generated core and are a subset of the following operations:

1. An initial phase where the core is initialized and no operations are performed.
2. Encode a codeblock.
3. Use a different codeblock configuration, with fewer symbols and fewer check symbols, as appropriate to the core.
4. Encode 20 codeblocks, streaming data continuously as fast as the core can process it.
5. Encode 10 more codeblocks which demonstrating the AXI control signals' use and effects.
6. If clock enable is present: Demonstrate the effect of toggling `aclken`.
7. If reset is present: Demonstrate the effect of asserting `aresetn`.

Customizing the Demonstration Test Bench

It is possible to modify the demonstration test bench to use different codeblock data or different control information.

Input data is pre-generated in the `create_ip_table` function and stored in the `IP_DATA` constant. Data from this constant is driven into the core by the `drive_input_codeblock` procedure.

For cores with an `S_AXIS_CTRL` control channel, control information is generated and driven into the core by the `ctrl_stimuli` process. Ensure that control information is provided for each data codeblock to prevent the core stalling.

The clock frequency of the core can be modified by changing the `CLOCK_PERIOD` constant.

Migrating

This appendix describes migrating from older versions of the IP to the current IP release.

Parameter Changes in the XCO File

The CORE Generator™ core update functionality can be used to update an existing XCO file from v7.1 to v8.0, but the update mechanism alone does not create a core compatible with v7.1. [Table 6-1](#) shows the changes to XCO parameters from v7.1 to v8.0.

Table 6-1: XCO Parameter Changes from v7.1 to v8.0

Version v7.1	Version v8.0	Notes
component_name	component_name	Unchanged
code_specification	code_specification	Unchanged
symbol_width	symbol_width	Unchanged
field_polynomial	field_polynomial	Unchanged
scaling_factor	scaling_factor	Unchanged
generator_start	generator_start	Unchanged
variable_block_length	variable_block_length	Unchanged
symbols_per_block	symbols_per_block	Unchanged
data_symbols	data_symbols	Unchanged
variable_number_of_check_symbols	variable_number_of_check_symbols	Unchanged
memory_style	memory_style	Unchanged
number_of_channels	number_of_channels	Unchanged
check_symbol_generator	check_symbol_generator	Unchanged
	output_has_tready	true if output channel has a TREADY input
clock_enable	aclken	Name change
synchronous_reset	aresetn	Name change. aresetn is active Low.
	info	true if info field is present in m_axis_output_tdata
	marker_bits	Controls whether TUSER port is included
	number_of_marker_bits	Width of optional TUSER port
nd		Replaced with AXI control signals
rdy		Replaced with AXI control signals

Table 6-1: XCO Parameter Changes from v7.1 to v8.0

Version v7.1	Version v8.0	Notes
rfd		Replaced with AXI control signals
rffd		Replaced with AXI control signals

Port Changes

Table 6-2: Port Changes from v7.1 to v8.0

Version v7.1	Version v8.0	Notes
CLK	aclk	Rename only
CE	aclken	Rename only
SCLR	aresetn	Rename and change on sense (now active Low). Must now be asserted for at least 2 cycles.
START		v8.0 does not require a pulse at the start of each block. s_axis_input_tvalid is used to detect this automatically.
BYPASS		Not available in v8.0 core
DATA_IN		Now exists as a field within s_axis_input_tdata
N_IN		Now exists as a field within s_axis_ctrl_tdata
R_IN		Now exists as a field within s_axis_ctrl_tdata
DATA_OUT		Now exists as a field within m_axis_output_tdata
INFO		Now exists as a field within m_axis_output_tdata
ND	s_axis_input_tvalid	
RFD	s_axis_input_tready	
RFFD		Control data can be written when s_axis_ctrl_tready is asserted in v8.0 core. Input data stream can be sampled when s_axis_input_tready is asserted.
RDY	m_axis_output_tvalid	

Additional Resources

Xilinx Resources

For support resources such as Answers, Documentation, Downloads, and Forums, see the Xilinx Support website at:

<http://www.xilinx.com/support>.

For a glossary of technical terms used in Xilinx documentation, see:

http://www.xilinx.com/support/documentation/sw_manuals/glossary.pdf.

Solution Centers

See the [Xilinx Solution Centers](#) for support on devices, software tools, and intellectual property at all stages of the design cycle. Topics include design assistance, advisories, and troubleshooting tips.

References

1. Xilinx AXI Design Reference Guide ([UG761](#))
2. [AMBA AXI4-Stream Protocol Specification](#)
3. Synthesis and Simulation Design Guide ([UG626](#))

Technical Support

Xilinx provides technical support at www.xilinx.com/support for this LogiCORE™ IP product when used as described in the product documentation. Xilinx cannot guarantee timing, functionality, or support of product if implemented in devices that are not defined in the documentation, if customized beyond that allowed in the product documentation, or if changes are made to any section of the design labeled DO NOT MODIFY.

See the IP Release Notes Guide ([XTP025](#)) for more information on this core. For each core, there is a master Answer Record that contains the Release Notes and Known Issues list for the core being used. The following information is listed for each version of the core:

- New Features
- Resolved Issues
- Known Issues

Ordering Information

Contact your local Xilinx [sales representative](#) for pricing and availability of Xilinx LogiCORE IP modules and software. Information about additional Xilinx LogiCORE IP modules is available on the Xilinx [IP Center](#).

Revision History

The following table shows the revision history for this document.

Date	Version	Revision
01/18/12	1.0	Initial Xilinx release. Previous data sheet for this core (non-AXI) is DS251.

Notice of Disclaimer

The information disclosed to you hereunder (the "Materials") is provided solely for the selection and use of Xilinx products. To the maximum extent permitted by applicable law: (1) Materials are made available "AS IS" and with all faults, Xilinx hereby DISCLAIMS ALL WARRANTIES AND CONDITIONS, EXPRESS, IMPLIED, OR STATUTORY, INCLUDING BUT NOT LIMITED TO WARRANTIES OF MERCHANTABILITY, NON-INFRINGEMENT, OR FITNESS FOR ANY PARTICULAR PURPOSE; and (2) Xilinx shall not be liable (whether in contract or tort, including negligence, or under any other theory of liability) for any loss or damage of any kind or nature related to, arising under, or in connection with, the Materials (including your use of the Materials), including for any direct, indirect, special, incidental, or consequential loss or damage (including loss of data, profits, goodwill, or any type of loss or damage suffered as a result of any action brought by a third party) even if such damage or loss was reasonably foreseeable or Xilinx had been advised of the possibility of the same. Xilinx assumes no obligation to correct any errors contained in the Materials or to notify you of updates to the Materials or to product specifications. You may not reproduce, modify, distribute, or publicly display the Materials without prior written consent. Certain products are subject to the terms and conditions of the Limited Warranties which can be viewed at <http://www.xilinx.com/warranty.htm>; IP cores may be subject to warranty and support terms contained in a license issued to you by Xilinx. Xilinx products are not designed or intended to be fail-safe or for use in any application requiring fail-safe performance; you assume sole risk and liability for use of Xilinx products in Critical Applications: <http://www.xilinx.com/warranty.htm#critapps>.

© Copyright 2012 Xilinx, Inc. Xilinx, the Xilinx logo, Artix, ISE, Kintex, Spartan, Virtex, Zynq, and other designated brands included herein are trademarks of Xilinx in the United States and other countries. Simulink is a registered trademark of The MathWorks, Inc. AMBA and ARM are trademarks of ARM in the EU and other countries. All other trademarks are the property of their respective owners.