

Synthesis and Simulation Design Guide

UG626 (v 13.1) March 1, 2011



Xilinx is disclosing this user guide, manual, release note, and/or specification (the “Documentation”) to you solely for use in the development of designs to operate with Xilinx hardware devices. You may not reproduce, distribute, republish, download, display, post, or transmit the Documentation in any form or by any means including, but not limited to, electronic, mechanical, photocopying, recording, or otherwise, without the prior written consent of Xilinx. Xilinx expressly disclaims any liability arising out of your use of the Documentation. Xilinx reserves the right, at its sole discretion, to change the Documentation without notice at any time. Xilinx assumes no obligation to correct any errors contained in the Documentation, or to advise you of any corrections or updates. Xilinx expressly disclaims any liability in connection with technical support or assistance that may be provided to you in connection with the Information.

THE DOCUMENTATION IS DISCLOSED TO YOU “AS-IS” WITH NO WARRANTY OF ANY KIND. XILINX MAKES NO OTHER WARRANTIES, WHETHER EXPRESS, IMPLIED, OR STATUTORY, REGARDING THE DOCUMENTATION, INCLUDING ANY WARRANTIES OF MERCHANTABILITY, FITNESS FOR A PARTICULAR PURPOSE, OR NONINFRINGEMENT OF THIRD-PARTY RIGHTS. IN NO EVENT WILL XILINX BE LIABLE FOR ANY CONSEQUENTIAL, INDIRECT, EXEMPLARY, SPECIAL, OR INCIDENTAL DAMAGES, INCLUDING ANY LOSS OF DATA OR LOST PROFITS, ARISING FROM YOUR USE OF THE DOCUMENTATION.

© Copyright 2002-2011 Xilinx Inc. All Rights Reserved. XILINX, the Xilinx logo, the Brand Window and other designated brands included herein are trademarks of Xilinx, Inc. All other trademarks are the property of their respective owners. The PowerPC name and logo are registered trademarks of IBM Corp., and used under license. All other trademarks are the property of their respective owners.

Table of Contents

Chapter 1 About the Synthesis and Simulation Design Guide	7
Synthesis and Simulation Design Guide Overview	7
Synthesis and Simulation Design Guide Design Examples	8
Synthesis and Simulation Design Guide Contents	8
Additional Resources.....	9
Conventions	9
Chapter 2 Hardware Description Language (HDL)	11
Advantages of Using a Hardware Description Language (HDL) to Design FPGA Devices	11
Designing FPGA Devices With Hardware Description Language (HDL)	12
Chapter 3 FPGA Design Flow.....	15
Design Flow Diagram	16
Design Entry Recommendations.....	16
Architecture Wizard.....	17
CORE Generator Software	19
Functional Simulation Early in the Design Flow.....	20
Synthesizing and Optimizing	21
Setting Constraints.....	23
Evaluating Design Size and Performance	24
Evaluating Coding Style and System Features.....	26
Placing and Routing.....	27
Timing Simulation.....	27
Chapter 4 General Recommendations for Coding Practices	29
Designing With Hardware Description Language (HDL).....	29
Naming, Labeling, and General Coding Styles.....	30
Specifying Constants	35
Using Generics and Parameters to Specify Dynamic Bus and Array Widths.....	36
TRANSLATE_OFF and TRANSLATE_ON.....	37
Chapter 5 Coding for FPGA Device Flow	39
VHDL and Verilog Limitations	40
Design Challenges in Using an Asynchronous First-In-First-Out (FIFO) Buffer	40
Advantages and Disadvantages of Hierarchical Designs.....	41

Using Synthesis Tools with Hierarchical Designs	42
Choosing Data Type.....	43
Using 'timescale	46
Mixed Language Designs	46
If Statements and Case Statements	47
Sensitivity List in Process and Always Statements.....	50
Delays in Synthesis Code	51
Registers in FPGA Design	51
Input Output Block (IOB) Registers	53
Latches in FPGA Design.....	55
Implementing Shift Registers	56
Describing Shift Registers.....	57
Control Signals.....	59
Initial State of the Registers and Latches	65
Initial State of the Shift Registers	66
Initial State of the RAMs.....	66
Multiplexers	67
Finite State Machine (FSM) Components.....	69
Implementing Memory.....	74
Block RAM Inference	75
Distributed RAM Inference	85
Arithmetic Support	87
Synthesis Tool Naming Conventions	99
Instantiating FPGA Primitives.....	99
Instantiating CORE Generator Software Modules	101
Attributes and Constraints	101
Pipelining	105
Retiming.....	106
Chapter 6 Simulating Your Design.....	107
Adhering to Industry Standards	107
Simulation Points in Hardware Description Language (HDL) Design Flow	109
Using Test Benches to Provide Stimulus	113
VHDL and Verilog Libraries and Models.....	115
Simulation of Configuration Interfaces	122
Disabling BlockRAM Collision Checks for Simulation.....	131
Global Reset and Tristate for Simulation	131
Design Hierarchy and Simulation	133

Register Transfer Level (RTL) Simulation Using Xilinx Libraries	136
Generating Gate-Level Netlist (Running NetGen)	138
Disabling X Propagation for Synchronous Elements	138
Using the ASYNC_REG Constraint	138
MIN/TYP/MAX Simulation.....	139
Special Considerations for DCM, DLL, and MMCM	142
Understanding Timing Simulation.....	145
Simulation Using Xilinx Supported EDA Simulation Tools.....	151
Chapter 7 Design Considerations.....	153
Understanding the Architecture.....	153
Clocking Resources.....	155
Defining Timing Requirements	158
Driving Synthesis	159
Choosing Implementation Options	161
Evaluating Critical Paths	162
SmartGuide Technology	163
Appendix A Simulating Xilinx Designs with ModelSim	167
Simulating Xilinx Designs in ModelSim	167
Simulating SecureIP with ModelSim and Questa	170
Appendix B Simulating Xilinx Designs in IES.....	171
Running Simulation from ISE Design Suite.....	171
Running Simulation in NC-Verilog.....	171
Running Simulation in NC-VHDL.....	173
Appendix C Simulating Xilinx Designs with Synopsys VCS and VCS MX.....	175
Simulating Xilinx® Designs from ISE Design Suite in Synopsys VCS and VCS MX.....	175
Simulating Xilinx Designs in Standalone Synopsys VCS and VCS MX	175
Simulating SecureIP with VCS	178

About the Synthesis and Simulation Design Guide

This chapter provides general information about the *Synthesis and Simulation Design Guide*. This chapter includes:

- [Synthesis and Simulation Design Guide Overview](#)
- [Synthesis and Simulation Design Guide Design Examples](#)
- [Synthesis and Simulation Design Guide Contents](#)
- [Additional Resources](#)
- [Conventions](#)

Synthesis and Simulation Design Guide Overview

The *Synthesis and Simulation Design Guide* provides a general overview of designing Field Programmable Gate Array (FPGA) devices using a Hardware Description Language (HDL). It includes design hints for the novice HDL user, as well as for the experienced user who is designing FPGA devices for the first time. Before using the *Synthesis and Simulation Design Guide*, you should be familiar with the operations that are common to all Xilinx® tools.

The *Synthesis and Simulation Design Guide* does *not* address certain topics that are important when creating HDL designs, such as:

- Design environment
- Verification techniques
- Constraining in the synthesis tool
- Test considerations
- System verification

For more information, see your synthesis tool documentation.

Synthesis and Simulation Design Guide Design Examples

The design examples in this Guide were:

- Created with VHDL and Verilog
Xilinx® endorses Verilog and VHDL equally. VHDL may be more difficult to learn than Verilog, and usually requires more explanation.
- Compiled with various synthesis tools
- Targeted for the following devices:
 - Spartan®-3
 - Spartan-3E
 - Spartan-3A
 - Spartan-6
 - Virtex®-4
 - Virtex-5
 - Virtex-6

Synthesis and Simulation Design Guide Contents

The *Synthesis and Simulation Design Guide* contains the following:

- Chapter One, [About the Synthesis and Simulation Design Guide](#), gives general information about this Guide
- Chapter Two, [Hardware Description Language \(HDL\)](#), describes how to design Field Programmable Gate Arrays (FPGA devices) using a Hardware Description Language (HDL).
- Chapter Three, [FPGA Design Flow](#), describes the steps in a typical FPGA design flow.
- Chapter Four, [General Recommendations for Coding Practices](#), contains general information relating to Hardware Description Language (HDL) coding styles and design examples to help you develop an efficient coding style.
- Chapter Five, [Coding for FPGA Flow](#), contains specific information relating to coding for FPGA devices.
- Chapter Six, [Simulating Your Design](#), describes the basic Hardware Description Language (HDL) simulation flow using Xilinx® and third party tools.
- Chapter Seven, [Design Considerations](#), describes understanding the architecture, clocking resources, defining timing requirements, driving synthesis, choosing implementation options, and evaluating critical paths.
- Appendix A provides information on [Simulating Xilinx Designs in ModelSim](#).
- Appendix B provides information on [Simulating Xilinx Designs in IES](#).
- Appendix C provides information on [Simulating Xilinx Designs in Synopsys VCS and VCS MX](#).

Additional Resources

- Global Glossary - http://www.xilinx.com/support/documentation/sw_manuals/glossary.pdf
- Xilinx Documentation - <http://www.xilinx.com/support/documentation>
- Xilinx Support - <http://www.xilinx.com/support>

Conventions

This document uses the following conventions. An example illustrates each convention.

Typographical

The following typographical conventions are used in this document:

Convention	Meaning or Use	Example
Courier font	Messages, prompts, and program files that the system displays	speed grade: - 100
Courier bold	Literal commands that you enter in a syntactical statement	ngdbuild <i>design_name</i>
Helvetica bold	Commands that you select from a menu	File > Open
	Keyboard shortcuts	Ctrl+C
<i>Italic font</i>	Variables in a syntax statement for which you must supply values	ngdbuild <i>design_name</i>
	References to other manuals	See the <i>Command Line Tools User Guide</i> for more information.
	Emphasis in text	If a wire is drawn so that it overlaps the pin of a symbol, the two nets are <i>not</i> connected.
Square brackets []	An optional entry or parameter. However, in bus specifications, such as bus[7:0] , they are required.	ngdbuild [<i>option_name</i>] <i>design_name</i>
Braces { }	A list of items from which you must choose one or more	lowpwr = { on off }
Vertical bar	Separates items in a list of choices	lowpwr = { on off }
Vertical ellipsis	Repetitive material that has been omitted	IOB #1: Name = QOUT IOB #2: Name = CLKIN . . .
Horizontal ellipsis . . .	Repetitive material that has been omitted	allow block . . . <i>block_name loc1 loc2 ... locn</i> ;

Online Document

The following conventions are used in this document:

Convention	Meaning or Use	Example
Blue text	Cross-reference link	See the section Additional Resources for details. Refer to Title Formats in Chapter 1 for details. See Figure 2-5 in the Virtex®-6 Handbook .

Hardware Description Language (HDL)

This chapter describes Hardware Description Language (HDL). This chapter includes:

- [Advantages of Using a Hardware Description Language \(HDL\) to Design FPGA Devices](#)
- [Designing FPGA Devices With Hardware Description Language \(HDL\)](#)

Designers use an HDL to describe the behavior and structure of system and circuit designs. Understanding FPGA architecture allows you to create HDL code that effectively uses FPGA system features. To learn more about designing FPGA devices with HDL:

- Enroll in training classes offered by Xilinx® and by synthesis tool vendors.
- Review the HDL design examples in this Guide.
- Download design examples from [Xilinx Support](#).
- Take advantage of the many other resources offered by Xilinx, including:
 - Documentation
 - Tutorials
 - Service packs
 - Telephone hotline
 - Answers database

For more information, see [Additional Resources](#).

Advantages of Using a Hardware Description Language (HDL) to Design FPGA Devices

Using a Hardware Description Language (HDL) to design high-density FPGA devices has the following advantages:

- [Top-Down Approach for Large Projects](#)
- [Functional Simulation Early in the Design Flow](#)
- [Synthesis of Hardware Description Language \(HDL\) Code to Gates](#)
- [Early Testing of Various Design Implementations](#)
- [Reuse of Register Transfer Level \(RTL\) Code](#)

Top-Down Approach for Large Projects

Designers use a Hardware Description Language (HDL) to create complex designs. The top-down approach to system design works well for large HDL projects that require many designers working together. After the design team determines the overall design plan, individual designers can work independently on separate code sections.

Functional Simulation Early in the Design Flow

You can verify design functionality early in the design flow by simulating the HDL description. Testing your design decisions before the design is implemented at the Register Transfer Level (RTL) or gate level allows you to make any necessary changes early on.

Synthesis of Hardware Description Language (HDL) Code to Gates

Synthesizing your hardware description to target the FPGA device implementation:

- Decreases design time by allowing a higher-level design specification, rather than specifying the design from the FPGA device base elements.
- Reduces the errors that can occur during a manual translation of a hardware description to a schematic design.
- Allows you to apply the automation techniques used by the synthesis tool (such as machine encoding styles and automatic I/O insertion) during optimization to the original Hardware Description Language (HDL) code. This results in greater optimization and efficiency.

Early Testing of Various Design Implementations

Using a Hardware Description Language (HDL) allows you to test different design implementations early in the design flow. Use the synthesis tool to perform the logic synthesis and optimization into gates.

Xilinx® FPGA devices allow you to implement your design at your computer. Since the synthesis time is short, you have more time to explore different architectural possibilities at the Register Transfer Level (RTL) You can reprogram Xilinx FPGA devices to test several design implementations.

Reuse of Register Transfer Level (RTL) Code

You can retarget Register Transfer Level (RTL) code to new FPGA devices with minimum recoding.

Designing FPGA Devices With Hardware Description Language (HDL)

This section discusses Designing FPGA Devices With Hardware Description Language (HDL), and includes:

- [About Designing FPGA Devices With Hardware Description Language \(HDL\)](#)
- [Designing FPGA Devices with VHDL](#)
- [Designing FPGA Devices with Verilog](#)
- [Designing FPGA Devices with Synthesis Tools](#)
- [Improving Device Performance Using FPGA System Features](#)
- [Designing Hierarchy](#)
- [Specifying Speed Requirements](#)

About Designing FPGA Devices With Hardware Description Language (HDL)

If you are used to schematic design entry, you may find it difficult at first to create Hardware Description Language (HDL) designs. You must make the transition from graphical concepts, such as block diagrams, state machines, flow diagrams, and truth tables, to abstract representations of design components. To ease this transition, keep your overall design plan in mind as you code in HDL.

To effectively use an HDL, you must understand the:

- Syntax of the language
- Synthesis and simulator tools
- Architecture of your target device
- Implementation tools

Designing FPGA Devices with VHDL

VHSIC Hardware Description Language (VHDL) is a hardware description language for designing integrated circuits. Since VHDL was not originally intended as an input to synthesis, many VHDL constructs are not supported by synthesis tools. The high level of abstraction of VHDL makes it easy to describe the system-level components and test benches that are not synthesized. In addition, the various synthesis tools use different subsets of VHDL.

The examples in this *Synthesis and Simulation Design Guide* work with most FPGA synthesis tools. The coding strategies presented in the remaining sections of this Guide can help you create Hardware Description Language (HDL) descriptions that can be synthesized.

Designing FPGA Devices with Verilog

Verilog is popular for synthesis designs because:

- Verilog is less verbose than traditional VHDL.
- Verilog is standardized as IEEE-STD-1364-95 and IEEE-STD-1364-2001.

Since Verilog was not originally intended as an input to synthesis, many Verilog constructs are not supported by synthesis tools. The Verilog coding examples in this Guide were tested and synthesized with current, commonly-used FPGA synthesis tools. The coding strategies presented in the remaining sections of this Guide can help you create Hardware Description Language (HDL) descriptions that can be synthesized.

SystemVerilog is a new emerging standard for both synthesis and simulation. It is not known if, or when, this standard will be adopted and supported by the various design tools.

Whether or not you plan to use this new standard, Xilinx® recommends that you:

- Review the standard to ensure that your current Verilog code can be readily carried forward as the new standard evolves.
- Review any new keywords specified by the standard.
- Avoid using the new keywords in your current Verilog code.

Designing FPGA Devices with Synthesis Tools

Most synthesis tools have special optimization algorithms for Xilinx® FPGA devices. Constraints and compiling options perform differently depending on the target device. Some commands and constraints in ASIC synthesis tools do not apply to FPGA devices. If you use them, they may adversely impact your results.

You should understand how your synthesis tool processes designs before you create FPGA designs. Most FPGA synthesis vendors include information in their documentation specifically for Xilinx FPGA devices.

Improving Device Performance Using FPGA System Features

To improve device performance, area utilization, and power characteristics, create Hardware Description Language (HDL) code that uses FPGA system features such as DCM, multipliers, shift registers, and memory. For a description of these and other features, see the device [data sheet](#) and [user guide](#).

The choice of the size (width and depth) and functional characteristics must be taken into account by understanding the target FPGA resources and making the proper system choices to best target the underlying architecture.

Designing Hierarchy

Using a Hardware Description Language (HDL) gives added flexibility in describing the design. Not all HDL code is optimized the same. How and where the functionality is described can have dramatic effects on end optimization. For example:

- Certain techniques may unnecessarily increase the design size and power while decreasing performance.
- Other techniques can result in more optimal designs in terms of any or all of those same metrics.

This Guide will help instruct you in techniques for optional FPGA design methodologies.

Design hierarchy is important in both the implementation of an FPGA and during interactive changes. Some synthesizers maintain the hierarchical boundaries unless you group modules together. Modules should have registered outputs so their boundaries are not an impediment to optimization. Otherwise, modules should be as large as possible within the limitations of your synthesis tool.

The “5,000 gates per module” rule is no longer valid, and can interfere with optimization. Check with your synthesis vendor for the preferred module size. As a last resort, use the grouping commands of your synthesizer, if available. The size and content of the modules influence synthesis results and design implementation. This Guide describes how to create effective design hierarchy.

Specifying Speed Requirements

To meet timing requirements, you must set timing constraints in both the synthesis tool and the placement and routing tool. If you specify the desired timing at the beginning, the tools can maximize not only performance, but also area, power, and tool runtime.

This may result in a design that:

- Achieves the desired performance
- Is smaller
- Consumes less power
- Requires less processing time

For more information, see [Setting Constraints](#).

FPGA Design Flow

This chapter describes the steps in a typical FPGA design flow. This chapter includes:

- [Design Flow Diagram](#)
- [Design Entry Recommendations](#)
- [Architecture Wizard](#)
- [CORE Generator™ Software](#)
- [Functional Simulation](#)
- [Synthesizing and Optimizing](#)
- [Setting Constraints](#)
- [Evaluating Design Size and Performance](#)
- [Evaluating Coding Style and System Features](#)
- [Placing and Routing](#)
- [Timing Simulation](#)

Design Flow Diagram

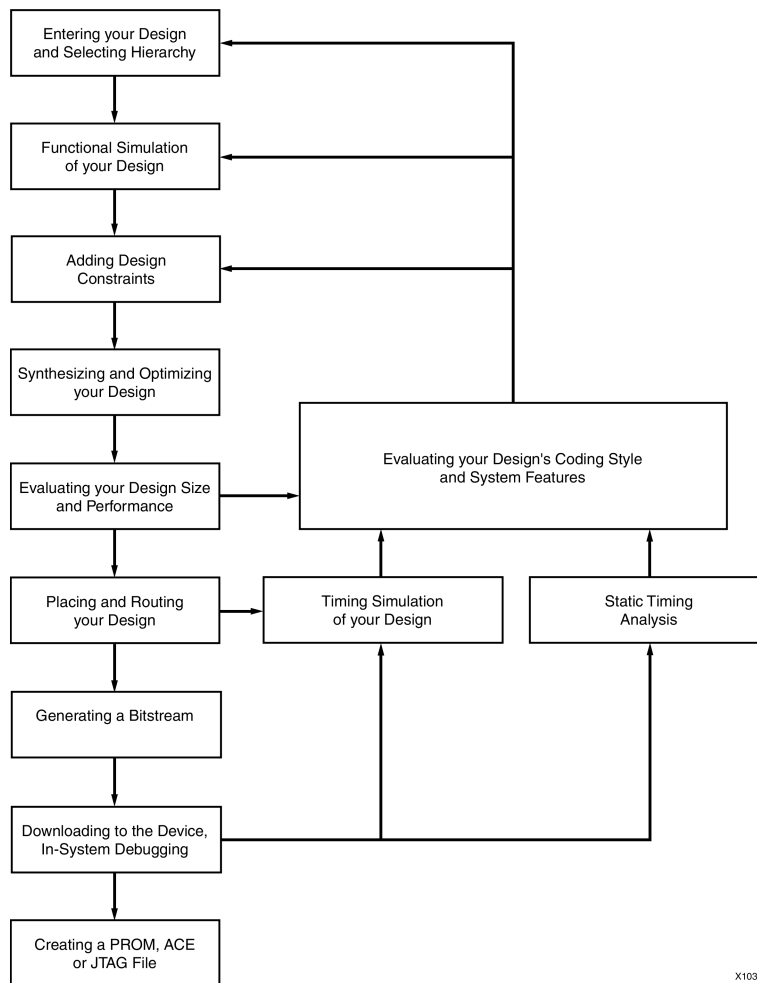

X10303

Design Entry Recommendations

Xilinx® recommends the following for design entry:

- [Use Register Transfer Level \(RTL\) Code](#)
- [Select the Correct Design Hierarchy](#)

Use Register Transfer Level (RTL) Code

Use Register Transfer Level (RTL) code, and, when possible, do not instantiate specific components. Following these two practices allows for:

- Readable code
- Ability to use the same code for synthesis and simulation
- Faster and simpler simulation
- Portable code for migration to different device families
- Reusable code for future designs

In some cases instantiating optimized CORE Generator™ software modules is beneficial with RTL.

Select the Correct Design Hierarchy

Select the correct design hierarchy to:

- Improve simulation and synthesis results
- Improve debugging
- Allow parallel engineering, in which a team of engineers can work on different parts of the design at the same time
- Improve placement and routing by reducing routing congestion and improving timing
- Allow for easier code reuse in both current and future designs

Architecture Wizard

Use Architecture Wizard to configure advanced features of Xilinx® devices. Architecture Wizard consists of several components for configuring specific device features. Each component functions as an independent wizard. For more information, see [Architecture Wizard Components](#).

Architecture Wizard creates a VHDL, Verilog, or Electronic Data Interchange Format (EDIF) file, depending on the flow type passed to it. The generated Hardware Description Language (HDL) output is a module consisting of one or more primitives and the corresponding properties, and not just a code snippet. This allows the output file to be referenced from the HDL Editor. No User Constraints File (UCF) is output, since the necessary attributes are embedded inside the HDL file.

Opening Architecture Wizard

You can open Architecture Wizard from:

- ISE® Design Suite
For more information, see the ISE Design Suite Help, especially *Working with Architecture Wizard IP*.
- The CORE Generator™ software
Select any of the Architecture Wizard IP from the list of available IP in the CORE Generator software window.
- The command line
Type **arwz**.

Architecture Wizard Components

Architecture Wizard components include:

- Clocking Wizard
- RocketIO™ Wizard
- ChipSync Wizard
- XtremeDSP™ Slice Wizard

Clocking Wizard

The Clocking Wizard enables:

- Digital clock setup
- DCM and clock buffer viewing
- DRC checking

The Clocking Wizard allows you to:

- View the DCM component
- Specify attributes
- Generate corresponding components and signals
- Execute DRC checks
- Display up to eight clock buffers
- Set up the Feedback Path information
- Set up the Clock Frequency Generator information and execute DRC checks
- View and edit component attributes
- View and edit component constraints
- View and configure one or two Phase Matched Clock Dividers (PMCDs) in a Virtex®-4 device
- View and configure a Phase Locked Loop (PLL) in a Virtex-5 device
- Automatically place one component in the XAW file
- Save component settings in a VHDL file
- Save component settings in a Verilog file

RocketIO Wizard

The RocketIO Wizard enables serial connectivity between devices, backplanes, and subsystems.

The RocketIO Wizard allows you to:

- Specify RocketIO type
- Define Channel Bonding options
- Specify General Transmitter Settings, including encoding, CRC, and clock
- Specify General Receptor Settings, including encoding, CRC, and clock
- Provide the ability to specify Synchronization
- Specify Equalization, Signal integrity tip (resister, termination mode ...)
- View and edit component attributes
- View and edit component constraints
- Automatically place one component in the XAW file
- Save component settings to a VHDL file or Verilog file

ChipSync Wizard

The ChipSync Wizard applies to Virtex-4 devices and Virtex-5 devices only.

The ChipSync Wizard:

- Facilitates the implementation of high-speed source synchronous applications.
- Configures a group of I/O blocks into an interface for use in memory, networking, or any other type of bus interface.
- Creates Hardware Description Language (HDL) code with these features configured according to your input:
 - Width and IO standard of data, address, and clocks for the interface
 - Additional pins such as reference clocks and control pins
 - Adjustable input delay for data and clock pins
 - Clock buffers (BUFIO) for input clocks
 - ISERDES/OSERDES or IDDR/ODDR blocks to control the width of data, clock enables, and tristate signals to the fabric

XtremeDSP Slice Wizard

The XtremeDSP Slice Wizard applies to Virtex-4 devices and Virtex-5 devices only.

The XtremeDSP Slice Wizard facilitates the implementation of the XtremeDSP Slice. For more information, see the:

- [data sheet](#) for Virtex-4 devices and Virtex-5 devices
- [XtremeDSP for Virtex-4 FPGAs User Guide](#)
- [Virtex-5 XtremeDSP User Guide](#)

CORE Generator Software

The CORE Generator™ software delivers parameterized Intellectual Property (IP) optimized for Xilinx® FPGA devices. It provides a catalog of ready-made functions ranging in complexity from FIFOs and memories to high level system functions. High level system functions can include:

- Reed-Solomon Decoder and Encoder
- FIR filters
- FFTs for DSP applications
- Standard bus interfaces (for example, the PCI™ and PCI-X™ bus interfaces)
- Connectivity and networking interfaces (for example, the Ethernet, SPI-4.2, and PCI EXPRESS® microprocessor interfaces)

For a typical core, the CORE Generator software produces the following files:

- EDN and NGC Files
- VHO Files
- VEO Files
- V and VHD Wrapper Files
- ASY Files

EDN and NGC Files

The Electronic Data Interchange Format (EDIF) Netlist (EDN) file and NGC files contain the information required to implement the module in a Xilinx FPGA device. Since NGC files are in binary format, ASCII NDF files may also be produced to communicate resource and timing information for NGC files to third party synthesis tools. The NDF file is read by the synthesis tool only and is not used for implementation.

VHO Files

VHDL template (VHO) template files contain code that can be used as a model for instantiating a CORE Generator software module in a VHDL design. VHO files come with a VHDL (VHD) wrapper file.

VEO Files

Verilog template (VEO) files contain code that can be used as a model for instantiating a CORE Generator software module in a Verilog design. VEO files come with a Verilog (V) wrapper file.

V and VHD Wrapper Files

V (Verilog) and VHD (VHDL) wrapper files support functional simulation. These files contain simulation model customization data that is passed to a parameterized simulation model for the core. In the case of Verilog designs, the V wrapper file also provides the port information required to integrate the core into a Verilog design for synthesis.

Some cores may generate actual source code or an additional top level Hardware Description Language (HDL) wrapper with clocking resource and Input Output Block (IOB) instances to enable you to tailor your clocking scheme to your own requirements. For more information, see the core-specific documentation.

The V (Verilog) and VHD (VHDL) wrapper files mainly support simulation and are not synthesizable.

ASCII Symbol (ASY) Files

ASCII Symbol (ASY) symbol information files allow you to integrate the CORE Generator software modules into a schematic design for ModelSim or ISE® Design Suite tools.

Functional Simulation Early in the Design Flow

Use functional or Register Transfer Level (RTL) simulation to verify syntax and functionality.

When you simulate your design, Xilinx® recommends that you:

- Perform Separate Simulations
With larger hierarchical Hardware Description Language (HDL) designs, perform separate simulations on each module before testing your entire design. This makes it easier to debug your code.
- Create a Test Bench
Once each module functions as expected, create a test bench to verify that your entire design functions as planned. Use the same test bench again for the final timing simulation to confirm that your design functions as expected under worst-case delay conditions.

You can use ModelSim simulators with ISE® Design Suite. The appropriate processes appear in ISE Design Suite when you choose ModelSim as your design simulator, provided you have installed any of the following:

ModelSim SE, ModelSim PE, or ModelSim DE

You can also use these simulators with third-party synthesis tools in ISE Design Suite.

Synthesizing and Optimizing

To improve results and decrease run time, follow these recommendations:

- [Creating a Compile Run Script](#)
- [Modifying Your Code to Successfully Synthesize Your Design](#)
- [Reading Cores](#)

For more information, see your synthesis tool documentation.

Creating a Compile Run Script

TCL scripting can make compiling your design easier and faster. With advanced scripting, you can:

- Run a compile multiple times using different options
- Write to different directories
- Run other command line tools

Running the TCL Script (Precision RTL Synthesis)

To run the TCL script from Precision RTL Synthesis:

1. Set up your project in Precision.
2. Synthesize your project.
3. Run the commands shown in Precision RTL Synthesis Commands to save and run the TCL script.

Precision RTL Synthesis Commands

Function	Command
Save the TCL script	File > Save Command File
Run the TCL script	File > Run Script
Run the TCL script from a command line	<code>c:\precision -shell -file project.tcl</code>
Complete synthesis	<pre> add_input_file top.vhdl setup_design -manufacturer xilinx-family virtex-6 -part 2v40cs144 -speed 6 compile synthesize </pre>

Running the TCL Script (Synplify)

To run the TCL script from Synplify:

Select **File > Run TCL Script**.

OR

Type `Synplify -batch script_file.tcl` at command prompt. Enter the following TCL commands in Synplify.

Synplify Commands

Function	Command
Start a new project	<code>project -new</code>
Set device options	<code>set_option -technology virtex</code> <code>set_option -part XCV50E</code> <code>set_option -package CS144</code> <code>set_option -speed_grade -8</code>
Add file options	<code>add_file -constraint watch.sdc</code> <code>add_file -vhdl -lib work macro1.vhd</code> <code>add_file -vhdl -lib work macro2.vhd</code> <code>add_file -vhdl -lib work top_level.vhd</code>
Set compilation and mapping options	<code>set_option -default_enum_encoding onehot</code> <code>set_option -symbolic_fsm_compiler true</code> <code>set_option -resource_sharing true</code>
Set simulation options	<code>set_option -write_verilog false</code> <code>set_option -write_vhdl false</code>
Set automatic Place and Route (vendor) options	<code>set_option -write_apr_cnstrnt true</code> <code>set_option -part XCV50E</code> <code>set_option -package CS144</code> <code>set_option -speed_grade -8</code>
Set result format and file options	<code>project -result_format edif</code> <code>project -result_file top_level.edf</code> <code>project -run</code> <code>project -save "watch.prj"</code>
Exit	<code>exit</code>

Running the TCL Script (XST)

For information on options used with the Xilinx Synthesis Technology (XST) see the [XST User Guide for Virtex-4, Virtex-5, Spartan-3, and Newer CPLD Devices](#).

Modifying Your Code to Successfully Synthesize Your Design

You may need to modify your code to successfully synthesize your design. Certain design constructs that are effective for *simulation* may not be as effective for *synthesis*. The synthesis syntax and code set may differ slightly from the simulator syntax and code set.

Reading Cores

The synthesis tools discussed in this section support incorporating the information in the CORE Generator™ software NDF files when performing design timing and area analysis.

Including the IP core NDF files in a design when analyzing a design results in better timing and resource optimizations for the surrounding logic. The NDF is used to estimate the delay through the logic elements associated with the IP core. The synthesis tools do not optimize the IP core itself, nor do they integrate the IP core netlist into the synthesized design output netlist.

Reading Cores (XST)

Run Xilinx Synthesis Technology (XST) using the **read_cores** switch. When the switch is set to **on** (the default), XST reads in Electronic Data Interchange Format (EDIF) and NGC netlists. For more information, see:

- [XST User Guide for Virtex-4, Virtex-5, Spartan-3, and Newer CPLD Devices](#)
- ISE® Design Suite help

Reading Cores (Synplify Pro)

When reading cores in Synplify Pro, Electronic Data Interchange Format (EDIF) is treated as another source format, but when reading in EDIF, you must specify the top level VHDL or Verilog in your project.

Reading Cores (Precision RTL Synthesis)

Precision RTL Synthesis can add Electronic Data Interchange Format (EDIF) and NGC files to your project as source files. For more information, see the Precision RTL Synthesis help.

Setting Constraints

Setting constraints:

- Allows you to control timing optimization
- Uses synthesis tools and implementation processes more efficiently
- Helps minimize runtime and achieve your design requirements

The Precision RTL Synthesis and Synplify constraint editing tools allow you to apply constraints to your Hardware Description Language (HDL) design.

For more information, see your synthesis tool documentation.

You can add the following constraints:

- Clock frequency or cycle and offset
- Input and Output timing
- Signal Preservation
- Module constraints
- Buffering ports
- Path timing
- Global timing

Specifying Constraints in the User Constraints File (UCF)

Constraints defined for synthesis can also be passed to implementation in a Netlist Constraints File (NCF) or the output Electronic Data Interchange Format (EDIF) file. However, Xilinx® recommends that you do *not* pass these constraints to implementation. Instead, specify your constraints separately in a User Constraints File (UCF). The UCF gives you tight control over the overall specifications by giving you the ability to:

- Access more types of constraints
- Define precise timing paths
- Prioritize signal constraints

For recommendations on constraining synthesis and implementation, see [Design Considerations](#). For information on specific timing constraints, together with syntax examples, see the [Constraints Guide](#).

Setting Constraints in ISE Design Suite

You can set constraints in ISE® Design Suite with:

- Constraints Editor
- PACE (CPLD devices only)
- PlanAhead™

For more information, see the ISE Design Suite Help.

Evaluating Design Size and Performance

Your design must:

- Function at the specified speed
- Fit in the targeted device

After your design is compiled, use the reporting options of your synthesis tool to determine preliminary device utilization and performance. After your design is mapped by ISE® Design Suite, you can determine the actual device utilization.

At this point, you should verify that:

- Your chosen device is large enough to accommodate any future changes or additions
- Your design performs as specified

Estimating Device Utilization and Performance

Use the area and timing reporting options of your synthesis tool to estimate device utilization and performance. After compiling, use the report area command to obtain a report of device resource utilization. Some synthesis tools provide area reports automatically. For correct command syntax, see your synthesis tool documentation.

These reports are usually accurate because the synthesis tool creates the logic from your code and maps your design into the FPGA device. These reports are different for the various synthesis tools. Some reports specify the minimum number of CLBs required, while other reports specify the unpacked number of CLBs to make an allowance for routing. For an accurate comparison, compare reports from the Xilinx® mapper tool after implementation.

Any instantiated components, such as CORE Generator™ software modules, Electronic Data Interchange Format (EDIF) files, or other components that your synthesis tool does not recognize during compilation, are not included in the report file. If you include these components, you must include the logic area used by these components when estimating design size. Sections may be trimmed during mapping, resulting in a smaller design.

Use the timing report command of your synthesis tool to obtain a report with estimated data path delays.

For more information, see your synthesis tool documentation.

The timing report is based on the logic level delays from the cell libraries and estimated wire-load models. While this report estimates how close you are to your timing goals, it is not the actual timing. An accurate timing report is available only after the design is placed and routed.

Determining Actual Device Utilization and Pre-Routed Performance

To determine if your design fits the specified device, map it using the Xilinx® Map program. The generated report file `design_name.mrp` contains the implemented device utilization information. To read the report file, double-click **Map Report** in the ISE® Design Suite Design Summary. Run the Map program from ISE Design Suite or from the command line.

Mapping Your Design Using ISE Design Suite

To map your design using ISE Design Suite:

1. Go to the **Processes** pane of the Design panel.
2. Click the plus (+) symbol in front of **Implement Design**.
3. Click **Map**.
4. To view the Map Report, double-click **Map Report**.

If the report does not exist, it is generated at this time. A green check mark in front of the report name indicates that the report is up-to-date, and no processing is performed.

5. If the report is not up-to-date:
 - a. Click the report name.
 - b. Select **Process > Rerun** to update the report.

The auto-make process automatically runs only the necessary processes to update the report before displaying it.

Alternatively, you may select **Process > Rerun All** to re-run all processes (even those processes that are up-to-date) from the top of the design to the stage where the report would be.

6. View the Logic Level Timing Report with the Report Browser. This report shows design performance based on logic levels and best-case routing delays.
7. Run the integrated Timing Analyzer to create a more specific report of design paths (optional).
8. Use the Logic Level Timing Report and any reports generated with the Timing Analyzer or the Map program to evaluate how close you are to your performance and utilization goals.

Use these reports to decide whether to proceed to the Place and Route phase of implementation, or to go back and modify your design or implementation options to attain your performance goals. You should have some slack in routing delays to allow the Place and Route tools to successfully complete your design. Use the verbose option in the Timing Analyzer to see block-by-block delay. The timing report of a mapped design (before Place and Route) shows block delays, as well as minimum routing delays.

A typical design for a Virtex®-4 device or a Virtex-5 device should allow 40% of the delay for logic, and 60% of the delay for routing. If most of your time is taken by logic, the design will probably not meet timing after Place and Route.

Mapping Your Design Using the Command Line

For available options, enter the `trce` command at the command line without any arguments.

To map your design using the command line:

1. To translate your design, run:

```
ngdbuild -p target_device design_name.edf (or ngc)
```

2. To map your design, run:

```
map design_name.ngd
```

3. Use a text editor to view the Device Summary section of the Map Report `<design_name.mrp>`.

The Device Summary section contains the device utilization information.

4. Run a timing analysis of the logic level delays from your mapped design as follows:

```
trce [options] design_name.ncd
```

Use the TRACE reports to:

- See how well the design meets performance goals
- Decide whether to proceed to Place and Route, or to modify your design or implementation options

Leave some slack in routing delays to allow the Place and Route tools to successfully complete your design.

Evaluating Coding Style and System Features

If you are not satisfied with design performance, re-evaluate your code. Modifying your code and selecting different compiler options can dramatically improve device utilization and speed.

Modifying Your Code to Improve Design Performance

To improve design performance:

1. Reduce levels of logic to improve timing by:
 - a. Using pipelining and re-timing techniques
 - b. Rewriting the Hardware Description Language (HDL) descriptions
 - c. Enabling or disabling resource sharing
2. Restructure logic to redefine hierarchical boundaries to help the compiler optimize design logic
3. Perform logic replication to reduce critical nets fanout to improve placement and reduce congestion
4. Take advantage of device resource with the CORE Generator™ software modules

Improving Resource Utilization Using FPGA System Features

After correcting any coding problems, use the following FPGA system features to improve resource utilization and enhance the speed of critical paths:

- Use clock enables.
- Use one-hot encoding for large or complex state machines.
- Use I/O registers when applicable.
- Use dedicated shift registers.
- In Virtex®-4 devices and Virtex-5 devices, use the dedicated DSP blocks.

Each device family has a unique set of system features. For more information about the system features available for your target device, see the device [data sheet](#).

Using Xilinx Specific Features of Your Synthesis Tool

Using the Xilinx® specific features of your synthesis tool allows better control over:

- Logic generated
- Number of logic levels
- Architecture elements used
- Fanout

If design performance is more than a few percentage points away from design requirements, advanced algorithms in the Place and Route (PAR) tool now make it more efficient to use your synthesis tool to achieve design performance. Most synthesis tools have special options for Xilinx specific features.

For more information, see your synthesis tool documentation.

Placing and Routing

The overall goal when placing and routing your design is fast implementation and high-quality results. You may not always accomplish this goal:

- Early in the design cycle, run time is usually more important than quality of results. Later in the design cycle, the reverse is usually true.
- If the targeted device is highly utilized, the routing may become congested, and your design may be difficult to route. In this case, the placer and router may take longer to meet your timing requirements.
- If design constraints are rigorous, it may take longer to correctly place and route your design, and meet the specified timing.

For more information, see the [Command Line Tools User Guide](#).

Timing Simulation

Timing simulation is important in verifying circuit operation after the worst-case placed and routed delays are calculated. In many cases, you can use the same test bench that you used for functional simulation to perform a more accurate simulation with less effort. Compare the results from the two simulations to verify that your design is performing as initially specified. The Xilinx® tools create a VHDL or Verilog simulation netlist of your placed and routed design, and provide libraries that work with many common Hardware Description Language (HDL) simulators. For more information, see [Simulating Your Design](#).

Timing-driven PAR is based on TRACE, the Xilinx timing analysis tool. TRACE is an integrated static timing analysis, and does not depend on input stimulus to the circuit. Placement and routing are executed according to the timing constraints that you specified at the beginning of the design process. TRACE interacts with PAR to make sure that the timing constraints you imposed are met.

If there are timing constraints, TRACE generates a report based on those constraints. If there are no timing constraints, TRACE can optionally generate a timing report containing:

- An analysis that enumerates all clocks and the required OFFSETs for each clock
- An analysis of paths having only combinatorial logic, ordered by delay

For more information on TRACE, see the [Command Line Tools User Guide](#). For more information on Timing Analysis, see the ISE® Design Suite Timing Analyzer Help.

General Recommendations for Coding Practices

This chapter contains general information relating to Hardware Description Language (HDL) coding styles and design examples. Its purpose is to help you develop an efficient coding style. For specific information relating to coding for FPGA devices, see [Coding for FPGA Flow](#). This chapter includes:

- [Designing With Hardware Description Language \(HDL\)](#)
- [Naming, Labeling, and General Coding Styles](#)
- [Specifying Constants](#)
- [Using Generics and Parameters to Specify Dynamic Bus and Array Widths](#)
- [TRANSLATE_OFF and TRANSLATE_ON](#)

Designing With Hardware Description Language (HDL)

A Hardware Description Language (HDL) contains many complex constructs that may be difficult to understand at first. The methods and examples included in HDL guides do not always apply to the design of FPGA devices. If you currently use HDLs to design ASIC devices, your established coding style may unnecessarily increase the number of logic levels in FPGA designs.

HDL synthesis tools implement logic based on the coding style of your design. To learn how to efficiently code with HDLs, you can:

- Attend training classes
- Read reference and methodology notes
- See synthesis guidelines and templates available from Xilinx® and synthesis tool vendors

When coding your designs, remember that an HDL is usually a VHSIC Hardware Description Language (VHDL). You should try to find a balance between the quality of the end hardware results and the speed of simulation.

This Guide will not teach you every aspect of VHDL or Verilog, but it will help you develop an efficient coding style.

Naming, Labeling, and General Coding Styles

Xilinx® recommends that you observe the following naming, labeling, and general coding styles:

- [Common Coding Style](#)
- [Xilinx Naming Conventions](#)
- [Reserved Names](#)
- [Naming Guidelines for Signals and Instances](#)
- [Matching File Names to Entity and Module Names](#)
- [Naming Identifiers](#)
- [Instantiating Sub-Modules](#)
- [Recommended Length of Line](#)
- [Common File Headers](#)
- [Indenting and Spacing](#)

Common Coding Style

Xilinx® recommends that your design team agree on a coding style at the beginning of your project. An established coding style allows you to read and understand code written by your team members. Inefficient coding styles can adversely impact synthesis and simulation, resulting in slow circuits. Because portions of existing Hardware Description Language (HDL) designs are often used in new designs, you should follow coding standards that are understood by the majority of HDL designers. This Guide describes recommended coding styles that you should establish before you begin your designs.

Xilinx Naming Conventions

Use Xilinx® naming conventions for naming signals, variables, and instances that are translated into nets, buses, and symbols.

- Avoid VHDL keywords (such as **entity**, **architecture**, **signal**, and **component**) even when coding in Verilog.
- Avoid Verilog keywords (such as **module**, **reg**, and **wire**) even when coding in VHDL. See *Annex B of System Verilog Spec version 3.1a*.
- A user-generated name should not contain a forward slash (/). The forward slash is usually used to denote a hierarchy separator.
- Names must contain at least one non-numeric character.
- Names must not contain a dollar sign (\$).
- Names must not use less-than (<) or greater-than signs (>). These signs are sometimes used to denote a bus index.

Reserved Names

The following FPGA resource names are reserved. Do not use them to name nets or components.

- Device architecture names (such as **CLB**, **IOB**, **PAD**, and **Slice**)
- Dedicated pin names (such as **CLK** and **INIT**)
- **GND** and **VCC**
- UNISIM primitive names such as **BUFG**, **DCM**, and **RAMB16**
- Do not use pin names such as **P1** or **A4** for component names

For language-specific naming restrictions, see the VHDL and Verilog reference manuals. Xilinx® does not recommend using escape sequences for illegal characters. If you plan to import schematics, or to use mixed language synthesis or verification, use the most restrictive character set.

Naming Guidelines for Signals and Instances

Naming conventions help you achieve:

- Maximum line length
- Coherent and legible code
- Allowance for mixed VHDL and Verilog design
- Consistent HDL code

General Naming Rules for Signals and Instances

Xilinx® recommends that you observe the following general naming rules:

- Do not use reserved words for signal or instance names.
- Do not exceed 16 characters for the length of signal and instance names, whenever possible.
- Create signal and instance names that reflect their connection or purpose.
- Do not use mixed case for any particular name or keyword. Use either all capitals, or all lowercase.

VHDL and Verilog Capitalization

Xilinx recommends that you observe the following guidelines when naming signals and instances in VHDL and Verilog.

lower case	UPPER CASE	Mixed Case
library names	USER PORTS	Comments
keywords	INSTANCE NAMES	—
module names	UNISIM COMPONENT NAMES	—
entity names	PARAMETERS	—
user component names	GENERICs	—
internal signals	—	—

Since Verilog is case sensitive, module and instance names can be made unique by changing their capitalization. For compatibility with file names, mixed language support, and other tools, Xilinx recommends that you rely on more than just capitalization to make instances unique.

Matching File Names to Entity and Module Names

When you name your Hardware Description Language (HDL) files:

- Make sure that the VHDL or Verilog source code file name matches the designated name of the entity (VHDL) or module (Verilog) specified in your design file. This is less confusing, and usually makes it easier to create a script file for compiling your design.
- If your design contains more than one entity or module, put each in a separate file. For VHDL designs, Xilinx® recommends grouping the entity and the associated architecture into the same file.
- Use the same name as your top-level design file for your synthesis script file with either a `.do`, `.scr`, `.script`, or other appropriate default script file extension for your synthesis tool.

Naming Identifiers

To make design code easier to debug and reuse:

- Use concise but meaningful identifier names.
- Use meaningful names for wires, regs, signals, variables, types, and any identifier in the code.

Example: **CONTROL_reg**

- Use underscores to make the identifiers easier to read.

Instantiating Sub-Modules

Xilinx® recommends the following when using instantiating sub-modules:

- Use named association. Named association prevents incorrect connections for the ports of instantiated components.
- Never combine positional and named association in the same statement.
- Use one port mapping per line to:
 - Improve readability
 - Provide space for a comment
 - Allow for easier modification

Incorrect and Correct VHDL and Verilog Coding Examples

	VHDL	Verilog
Incorrect	<pre>CLK_1: BUFG port map (I=>CLOCK_IN, CLOCK_OUT);</pre>	<pre>BUFG CLK_1 (.I(CLOCK_IN), CLOCK_OUT);</pre>
Correct	<pre>CLK_1: BUFG port map(I=>CLOCK_IN, O=>CLOCK_OUT);</pre>	<pre>BUFG CLK_1 (.I(CLOCK_IN), .O(CLOCK_OUT));</pre>

Instantiating Sub-Modules VHDL Coding Example

```
-- FDCPE: Single Data Rate D Flip-Flop with Asynchronous Clear, Set and
-- Clock Enable (posedge clk). All families.
-- Xilinx HDL Language Template

FDCPE_inst : FDCPE
generic map (
  INIT => '0') -- Initial value of register ('0' or '1')
port map (
  Q => Q,    -- Data output
  C => C,    -- Clock input
  CE => CE,  -- Clock enable input
  CLR => CLR, -- Asynchronous clear input
  D => D,    -- Data input
  PRE => PRE -- Asynchronous set input
);

-- End of FDCPE_inst instantiation
```

Instantiating Sub-Modules Verilog Coding Example

```
// FDCPE: Single Data Rate D Flip-Flop with Asynchronous Clear, Set and
// Clock Enable (posedge clk). All families.
// Xilinx HDL Language Template

FDCPE #(
  .INIT(1'b0) // Initial value of register (1'b0 or 1'b1)
) FDCPE_inst (
  .Q(Q),     // Data output
  .C(C),     // Clock input
  .CE(CE),   // Clock enable input
  .CLR(CLR), // Asynchronous clear input
  .D(D),     // Data input
  .PRE(PRE)  // Asynchronous set input
);

// End of FDCPE_inst instantiation
```

Recommended Length of Line

Xilinx® recommends that a line of VHDL or Verilog code not exceed 80 characters. Choose signal and instance names carefully in order to not exceed the 80 character limit.

If a line must exceed 80 characters, break it with the continuation character, and align the subsequent lines with the preceding code.

Avoid excessive nests in the code, such as nested **if** and **case** statements. Excessive nesting can make the line too long, as well as inhibit optimization. By limiting nested statements, code is usually more readable and more portable, and can be more easily formatted for printing.

Common File Headers

Xilinx® recommends that you use a common file header surrounded by comments at the beginning of each file. A common file header:

- Allows better documentation
- Improves code revision tracking
- Enhances reuse

The header contents depend on personal and company standards.

VHDL File Header Example

```
-----  
-- Copyright (c) 1996-2010 Xilinx, Inc.  
-- All Rights Reserved  
--  
-- / / \ / / Company: Xilinx  
-- / ___ / \ / Design Name: MY_CPU  
-- \ \ \ / \ / Filename: my_cpu.vhd  
-- \ \ \ Version: 1.1.1  
-- / / \ Date Last Modified: Fri Sep 24 2009  
-- / ___ / \ / Date Created: Tue Sep 21 2009  
-- \ \ \ / \  
-- \ ___ \ / \ ___ \  
--  
--Device: XC3S1000-5FG676  
--Software Used: ISE 11.1  
--Libraries used: UNISIM  
--Purpose: CPU design  
--Reference:  
-- CPU specification found at: http://www.mycpu.com/docs  
--Revision History:  
-- Rev 1.1.0 - First created, joe_engineer, Tue Sep 21 2009.  
-- Rev 1.1.1 - Ran changed architecture name from CPU_FINAL  
-- john_engineer, Fri Sep 24 2009.
```

Indenting and Spacing

Proper indentation in code offers these benefits:

- More readable and comprehensible code by showing grouped constructs at the same indentation level
- Fewer coding mistakes
- Easier debugging

Code Indentation VHDL Coding Example

```
entity AND_OR is
  port (
    AND_OUT : out std_logic;
    OR_OUT  : out std_logic;
    I0      : in  std_logic;
    I1      : in  std_logic;
    CLK     : in  std_logic;
    CE      : in  std_logic;
    RST     : in  std_logic);
end AND_OR;
architecture BEHAVIORAL_ARCHITECTURE of AND_OR is
  signal and_int : std_logic;
  signal or_int  : std_logic;
begin
  AND_OUT <= and_int;
  OR_OUT  <= or_int;
  process (CLK)
  begin
    if (CLK'event and CLK='1') then
      if (RST='1') then
        and_int <= '0';
        or_int  <= '0';
      elsif (CE='1') then
        and_int <= I0 and I1;
        or_int  <= I0 or I1;
      end if;
    end if;
  end process;
end AND_OR;
```

Code Indentation Verilog Coding Example

```
module AND_OR (AND_OUT, OR_OUT, I0, I1, CLK, CE, RST);
  output reg AND_OUT, OR_OUT;
  input  I0, I1;
  input  CLK, CE, RST;
  always @(posedge CLK)
    if (RST) begin
      AND_OUT <= 1'b0;
      OR_OUT  <= 1'b0;
    end else (CE) begin
      AND_OUT <= I0 and I1;
      OR_OUT  <= I0 or I1;
    end
end
endmodule
```

Specifying Constants

Use constants in your design to substitute numbers with more meaningful names. Constants make a design more readable and portable.

Specifying constants can be a form of in-code documentation that allows for easier understanding of code function.

- For VHDL, Xilinx® recommends not using variables for constants. Define constant numeric values as constants, and use them by name.
- For Verilog, parameters can be used as constants in the code in a similar manner. This coding convention allows you to easily determine if several occurrences of the same literal value have the same meaning.

In the following coding examples, the **OPCODE** values are declared as constants or parameters, and the names refer to their function. This method produces readable code that is easier to understand and modify.

Using Constants and Parameters VHDL Coding Example

```
constant ZERO : STD_LOGIC_VECTOR (1 downto 0):=00; constant A_B: STD_LOGIC_VECTOR (1 downto 0):=01;
constant A_B : STD_LOGIC_VECTOR (1 downto 0):=10;
constant ONE : STD_LOGIC_VECTOR (1 downto 0):=11;
process (OPCODE, A, B)
begin
    if (OPCODE = A_B)then OP_OUT <= A and B;
    elsif (OPCODE = A_B) then
        OP_OUT <= A or B;
    elsif (OPCODE = ONE) then
        OP_OUT <= '1';
    else
        OP_OUT <= '0';
    end if;
end process;
```

Using Constants and Parameters Verilog Coding Example

```
//Using parameters for OPCODE functions
parameter ZERO = 2'b00;
parameter A_B = 2'b01;
parameter A_B = 2'b10;
parameter ONE = 2'b11;
always @ (*)
begin
    if (OPCODE == ZERO)
        OP_OUT = 1'b0;
    else if (OPCODE == A_B)
        OP_OUT=A&B;
    else if (OPCODE == A_B)
        OP_OUT = A|B;
    else
        OP_OUT = 1'b1;
end
```

Using Generics and Parameters to Specify Dynamic Bus and Array Widths

To specify a dynamic or paramatizable bus width for a VHDL or Verilog design module:

- Define a generic (VHDL) or parameter (Verilog).
- Use the generic (VHDL) or parameter (Verilog) to define the bus width of a port or signal.

The generic (VHDL) or parameter (Verilog) can contain a default which can be overridden by the instantiating module. This can make the code easier to reuse, as well as making it more readable.

VHDL Generic Coding Example

```
-- FIFO_WIDTH data width (number of bits)
-- FIFO_DEPTH by number of address bits
-- for the FIFO RAM i.e. 9 -> 2**9 -> 512 words
-- FIFO_RAM_TYPE: BLOCKRAM or DISTRIBUTED_RAM
-- Note: DISTRIBUTED_RAM suggested for FIFO_DEPTH
-- of 5 or less
entity async_fifo is
  generic (FIFO_WIDTH: integer := 16;)
    FIFO_DEPTH: integer := 9; FIFO_RAM_TYPE: string := "BLOCKRAM");
  rd_clk : in std_logic;
  rd_en  : in std_logic;
  ainit  : in std_logic;
  wr_clk : in std_logic;
  wr_en  : in std_logic;
  dout   : out std_logic_vector(FIFO_WIDTH-1 downto 0) := (others=> '0');
  empty  : out std_logic := '1';
  full   : out std_logic := '0';
  almost_empty : out std_logic := '1';
  almost_full  : out std_logic := '0');
end async_fifo;
architecture BEHAVIORAL of async_fifo is
  type ram_type is array ((2**FIFO_DEPTH)-1 downto 0) of std_logic_vector (FIFO_WIDTH-1 downto 0);
```

Verilog Parameter Coding Example

```
-- FIFO_WIDTH data width(number of bits)
-- FIFO_DEPTH by number of address bits
-- for the FIFO RAM i.e. 9 -> 2**9 -> 512 words
-- FIFO_RAM_TYPE: BLOCKRAM or DISTRIBUTED_RAM
-- Note: DISTRIBUTED_RAM suggested for FIFO_DEPTH
-- of 5 or less
module async_fifo (din, rd_clk, rd_en, ainit, wr_clk,
wr_en, dout, empty, full, almost_empty, almost_full, wr_ack);
  parameter FIFO_WIDTH = 16;
  parameter FIFO_DEPTH = 9;
  parameter FIFO_RAM_TYPE = "BLOCKRAM";
  input [FIFO_WIDTH-1:0] din;
  input rd_clk;
  input rd_en;
  input ainit;
  input wr_clk;
  input wr_en;
  output reg [FIFO_WIDTH-1:0] dout;
  output empty;
  output full;
  output almost_empty;
  output almost_full;
  output reg wr_ack;
  reg [FIFO_WIDTH-1:0] fifo_ram [(2**FIFO_DEPTH)-1:0];
```

TRANSLATE_OFF and TRANSLATE_ON

The synthesis directives **TRANSLATE_OFF** and **TRANSLATE_ON** were formerly used when passing generics or parameters for synthesis tools, since most synthesis tools were unable to read generics or parameters. These directives were also used for library declarations such as library UNISIM, since synthesis tools did not understand that library.

Since most synthesis tools can now read generics and parameters and understand the UNISIM library, you no longer need to use these directives in synthesizable code. **TRANSLATE_OFF** and **TRANSLATE_ON** can also be used to embed simulation-only code in synthesizable files. Xilinx® recommends that any simulation-only constructs reside in simulation-only files or test benches.

For more information about `TRANSLATE_OFF` and `TRANSLATE_ON`, see the [Constraints Guide](#).

Coding for FPGA Device Flow

This chapter contains specific information relating to coding for FPGA devices. For general information relating to Hardware Description Language (HDL), see [General Recommendations for Coding Practices](#). This chapter includes:

- [VHDL and Verilog Limitations](#)
- [Design Challenges in Using an Asynchronous First-In-First-Out \(FIFO\) Buffer](#)
- [Advantages and Disadvantages of Hierarchical Designs](#)
- [Using Synthesis Tools with Hierarchical Designs](#)
- [Choosing Data Type](#)
- [Using 'timescale](#)
- [Mixed Language Designs](#)
- [If Statements and Case Statements](#)
- [Sensitivity List in Process and Always Statements](#)
- [Delays in Synthesis Code](#)
- [Registers in FPGA Design](#)
- [Input Output Block \(IOB\) Registers](#)
- [Latches in FPGA Design](#)
- [Implementing Shift Registers](#)
- [Describing Shift Registers](#)
- [Control Signals](#)
- [Initial State of the Registers and Latches](#)
- [Initial State of the Shift Registers](#)
- [Initial State of the RAMs](#)
- [Finite State Machine \(FSM\) Components](#)
- [Implementing Memory](#)
- [Block RAM Inference](#)
- [Distributed RAM Inference](#)
- [Arithmetic Support](#)
- [Synthesis Tool Naming Conventions](#)
- [Instantiating FPGA Primitives](#)
- [Instantiating CORE Generator™ Software Modules](#)
- [Attributes and Constraints](#)
- [Pipelining](#)
- [Retiming](#)

VHDL and Verilog Limitations

VHDL and Verilog were not originally intended as inputs to synthesis. For this reason, synthesis tools do not support many hardware description and simulation constructs. In addition, synthesis tools may use different subsets of VHDL and Verilog. VHDL and Verilog semantics are well defined for design simulation. The synthesis tools must adhere to these semantics to ensure that designs simulate the same way before and after synthesis. Observe the guidelines in the following sections to create code that is most suitable for Xilinx® design flow.

Design Challenges in Using an Asynchronous First-In-First-Out (FIFO) Buffer

Designers often use an asynchronous First-In-First-Out (**FIFO**) buffer (also known as an async **FIFO** or multi-rate **FIFO**) to transfer data from one clock domain to another. In order to determine the status of the **FIFO** and safely transfer the data, the design must monitor and react to status flags (**empty** and **full** signals).

Since these flags are based on two clock domains that do not have related phases or periods, the timing and predictability of the flags can not always be readily determined. For this reason, you must take special precautions when using an asynchronous **FIFO**.

Flag assertion and de-assertion for most asynchronous **FIFO** implementations is not inherently cycle deterministic. A functional or timing simulation may show the status flag changing on one clock cycle, while on the FPGA device itself, the status flag may change in the previous or next clock cycle. This may occur when the timing and order of events in the simulator differs from the timing and order of events in the FPGA device.

The end timing of the FPGA device is determined by process, voltage, and temperature (**PVT**). It is therefore possible to have cycle differences on different chips, as well as under different environmental conditions on the same chip. You must be sure to take these differences into account when designing your circuits.

You may encounter problems if you expect data to be valid after or during a certain number of clock cycles, and you do not monitor the empty and full flags directly. In most **FIFO** implementations, even if there is memory space, reading from a **FIFO** that has its empty flag asserted, or writing to a **FIFO** that has its full flag asserted, gives an invalid read or write condition. This can lead to unexpected results, and can create a serious debugging problem. Xilinx® strongly recommends that you always monitor the status flags, regardless of whether the asynchronous **FIFO** implementation passes simulation.

In most asynchronous **FIFO** implementations, empty and full flags default to a safe condition when a read and a write is performed at or near the same time at status flag boundaries. A full flag may assert even if the **FIFO** is not actually full. An empty flag may assert even if the **FIFO** is not actually empty. This prevents either flag from not asserting when the **FIFO** is empty or full. A false full or false empty flag may result depending on (a) the timing of the two clock domains and (b) the occurrence of a read and a write close together when the **FIFO** is nearly empty or full. This must be accounted for in the design to ensure proper operation under all conditions.

Many designers either use the CORE Generator™ software, or instantiate the **FIFO** primitive (**FIFO18** for example), in order to realize their **FIFO** circuit. Other designers implement their own **FIFO** logic in order to create a more portable, more customized, and more efficient implementation.

Various synthesis and simulation directives can allow the asynchronous **FIFO** to behave in a known manner when testing asynchronous conditions.

- In many cases, a timing violation can not be avoided when designing **FIFO** flag logic. If a timing violation occurs during timing simulation, the simulator produces an unknown (**X**) output to indicate the unknown state. For this reason, if logic is being driven from a known asynchronous source, and the proper design precautions were made to ensure proper operation regardless of the violation, Xilinx recommends adding the **ASYNC_REG=TRUE** attribute to the associated flag register. This indicates that the register can safely receive asynchronous input. Timing violations on the register no longer result in an **X**, but instead maintain its previous value. This can also prevent the software from replicating the register, or performing other optimizations that can have a negative affect on the register operation. For more information, see [Disabling X Propagation for Synchronous Elements](#).
- A memory collision may take place when a read occurs at the same time as a write to the same memory location. Memory collisions should generally be avoided, since they can corrupt the read data. The memory collision can be safely ignored only if the read data is disregarded in the logic or design. In those rare cases, you can disable collision checking with the **SIM_COLLISION_CHECK** attribute on the RAM model. For more information, see [Disabling BlockRAM Collision Checks for Simulation](#).

Advantages and Disadvantages of Hierarchical Designs

Hardware Description Language (HDL) designs can either be described (synthesized) as a large flat module, or as many small modules. Each methodology has its advantages and disadvantages. As higher density FPGA devices are created, the advantages of hierarchical designs outweigh many of the disadvantages.

Some advantages of hierarchical designs are:

- Provide easier and faster verification and simulation
- Allow several engineers to work on one design at the same time
- Speed up design compilation
- Produce designs that are easier to understand
- Manage the design flow efficiently

Some disadvantages of hierarchical designs are:

- Design mapping into the FPGA device may not be optimal across hierarchical boundaries. This can cause lesser device utilization and decreased design performance. If special care is taken, the effect of this can be minimized.
- Design file revision control becomes more difficult.
- Designs become more verbose.

You can overcome most of these disadvantages with careful design consideration when you choose the design hierarchy.

Using Synthesis Tools with Hierarchical Designs

Effectively partitioning your designs can significantly reduce compile time and improve synthesis results. To effectively partition your design:

- Restrict Shared Resources
- Compile Multiple Instances
- Restrict Related Combinatorial Logic
- Separate Speed Critical Paths
- Restrict Combinatorial Logic
- Restrict Module Size
- Register All Outputs
- Restrict One Clock to Each Module or to Entire Design

Restrict Shared Resources

Place resources that can be shared on the same hierarchy level. If these resources are not on the same hierarchy level, the synthesis tool cannot determine if they should be shared.

Compile Multiple Instances

Compile multiple occurrences of the same instance together to reduce the gate count. To increase design speed, do not compile a module in a critical path with other instances.

Restrict Related Combinatorial Logic

Keep related combinatorial logic in the same hierarchical level to allow the synthesis tool to optimize an entire critical path in a single operation. Boolean optimization does not operate across hierarchical boundaries. If a critical path is partitioned across boundaries, logic optimization is restricted. Constraining modules is difficult if combinatorial logic is not restricted to the same hierarchy level.

Separate Speed Critical Paths

To achieve satisfactory synthesis results, locate design modules with different functions at different hierarchy levels. Design speed is the first priority of optimization algorithms. To achieve a design that efficiently utilizes device area, remove timing constraints from design modules.

Restrict Combinatorial Logic

To reduce the number of CLBs used, restrict combinatorial logic that drives a register to the same hierarchical block.

Restrict Module Size

Restrict module size to 100 - 200 CLBs. This range varies based on:

- Your computer configuration
- Whether the design is worked on by a design team
- The target FPGA device routing resources

Although smaller blocks give you more control, you may not always obtain the most efficient design. During final compilation, you may want to compile fully from the top down.

For more information, see your synthesis tool documentation.

Register All Outputs

Arrange your design hierarchy so that registers drive the module output in each hierarchical block. Registering outputs makes your design easier to constrain, since you only need to constrain the clock period and the **ClockToSetup** of the previous module. If you have multiple combinatorial blocks at different hierarchy levels, you must manually calculate the delay for each module. Registering the outputs of your design hierarchy can eliminate any possible problems with logic optimization across hierarchical boundaries.

Restrict One Clock to Each Module or to Entire Design

By restricting one clock to each module, you need only to describe the relationship between the clock at the top hierarchy level and each module clock.

By restricting one clock to the entire design, you need only to describe the clock at the top hierarchy level.

For more information on optimizing logic across hierarchical boundaries and compiling hierarchical designs, see your synthesis tool documentation.

Choosing Data Type

Note This section applies to VHDL only.

This section discusses Choosing Data Type, and includes:

- [Use Std_logic \(IEEE 1164\)](#)
- [Declaring Ports](#)
- [Arrays in Port Declarations](#)
- [Minimize Ports Declared as Buffers](#)

Use Std_logic (IEEE 1164)

Use the **std_logic** (IEEE 1164) standards for hardware descriptions when coding your design. These standards are recommended for the following reasons:

1. **std_logic** applies as a wide range of state values
std_logic has nine different values that represent most of the states found in digital circuits.
2. **std_logic** allows indication of all possible logic states within the FPGA
 - a. **std_logic** not only allows specification of logic high (**1**) and logic low (**0**), but also whether a pullup (**H**) or pulldown (**L**) is used, or whether an output is in high impedance (**Z**).
 - b. **std_logic** allows the specification of unknown values (**X**) due to possible contention, timing violations, or other occurrences, or whether an input or signal is unconnected (**U**).
 - c. **std_logic** allows a more realistic representation of the FPGA logic for both synthesis and simulation, frequently giving more accurate results.
3. **std_logic** easily performs board-level simulation

For example, if you use an integer type for ports for one circuit and standard logic for ports for another circuit, your design can be synthesized. However, you must perform time-consuming type conversions for a board-level simulation.

The back-annotated netlist from Xilinx® implementation is in **std_logic**. If you do not use **std_logic** type to drive your top-level entity in the test bench, you cannot reuse your functional test bench for timing simulation. Some synthesis tools can create a wrapper for type conversion between the two top-level entities. Xilinx does not recommend this practice.

Declaring Ports

Use the **std_logic** type for all entity port declarations. The **std_logic** type makes it easier to integrate the synthesized netlist back into the design hierarchy without requiring conversion functions for the ports. The following VHDL coding example uses the **std_logic** for port declarations:

```
Entity alu is
    port(
        A  : in STD_LOGIC_VECTOR(3 downto 0);
        B  : in STD_LOGIC_VECTOR(3 downto 0);
        CLK : in STD_LOGIC;
        C  : out STD_LOGIC_VECTOR(3 downto 0)
    );
end alu;
```

If a top-level port is specified as a type other than **std_logic**, software generated simulation models (such as timing simulation) may no longer bind to the test bench. This is due to the following factors:

- Type information cannot be stored for a particular design port.
- Simulation of FPGA hardware requires the ability to specify the values of **std_logic** such as **high-Z** (tristate), and **x** (unknown) in order to properly display hardware behavior.

Xilinx® recommends that you:

- Do not declare arrays as ports. This information cannot be properly represented or re-created.
- Use **std_logic** and **STD_LOGIC_VECTOR** for all top-level port declarations.

Arrays in Port Declarations

Although VHDL allows you to declare a port as an array type, Xilinx® recommends that you not do so, for the following reasons:

- Incompatibility with Verilog
- Inability to Store and Re-Create Original Array Declaration
- Mis-Correlation of Software Pin Names

Incompatibility with Verilog

There is no equivalent way to declare a port as an array type in Verilog. Verilog does not allow ports to be declared as arrays. This limits portability across languages. It also limits as the ability to use the code for mixed-language projects.

Inability to Store and Re-Create Original Array Declaration

When you declare a port as an array type in VHDL, the original array declaration cannot be stored and re-created. The Electronic Data Interchange Format (EDIF) netlist format, as well as the Xilinx database, are unable to store the original type declaration for the array.

As a result, when NetGen or another Netlister attempts to re-create the design, there is no information as to how the port was originally declared. The resulting netlist generally has mis-matched port declarations and resulting signal names. This is true not only for the top-level port declarations, but also for the lower-level port declarations of a hierarchical design since **KEEP_HIERARCHY** can be used to attempt to preserve those net names.

Mis-Correlation of Software Pin Names

Array port declarations can cause a mis-correlation of the software pin names from the original source code. Since the software must treat each I/O as a separate label, the corresponding name for the broken-out port may not match your expectation. This makes design constraint passing, design analysis, and design reporting more difficult to understand.

Minimize Ports Declared as Buffers

Do not use buffers when a signal is used internally and as an output port. See the following VHDL coding examples.

Signal C Used Internally and As Output Port VHDL Coding Example

In the following VHDL coding example, signal **C** is used internally and as an output port:

```
Entity alu is
    port(
        A : in STD_LOGIC_VECTOR(3 downto 0);
        B : in STD_LOGIC_VECTOR(3 downto 0);
        CLK : in STD_LOGIC;
        C : buffer STD_LOGIC_VECTOR(3 downto 0) );
end alu;
architecture BEHAVIORAL of alu is
begin
    process begin
        if (CLK'event and CLK='1') then
            C <= UNSIGNED(A) + UNSIGNED(B) UNSIGNED(C);
        end if;
    end process;
end BEHAVIORAL;
```

Because signal **C** is used both internally and as an output port, every level of hierarchy in your design that connects to port **C** must be declared as a buffer. Buffer types are not commonly used in VHDL designs because they can cause errors during synthesis.

Dummy Signal with Port C Declares as Output VHDL Coding Example

To reduce buffer coding in hierarchical designs, insert a dummy signal and declare port **C** as an output, as shown in the following VHDL coding example:

```
Entity alu is
    port(
        A : in STD_LOGIC_VECTOR(3 downto 0);
        B : in STD_LOGIC_VECTOR(3 downto 0);
        CLK : in STD_LOGIC;
        C : out STD_LOGIC_VECTOR(3 downto 0)
    );
end alu;
architecture BEHAVIORAL of alu is
    -- dummy signal
    signal C_INT : STD_LOGIC_VECTOR(3 downto 0);
begin
    C <= C_INT;
    process begin
        if (CLK'event and CLK='1') then
            C_INT <= A and B and C_INT;
        end if;
    end process;
end BEHAVIORAL;
```

Using 'timescale

Note This section applies to Verilog only.

All Verilog test bench and source files should contain a `'timescale` directive, or reference an include file containing a `'timescale` directive. Place the `'timescale` directive or reference near the beginning of the source file, and before any module or other design unit definitions in the source file.

Xilinx® recommends that you use a `'timescale` with a resolution of **1ps**. Some Xilinx primitive components such as **DCM** require a **1ps** resolution in order to work properly in either functional or timing simulation. There is little or no simulation speed difference for a **1ps** resolution as compared to a coarser resolution.

The following directive is a typical default:

```
'timescale 1ns/1ps
```

Mixed Language Designs

Most FPGA synthesis tools allow you to create projects containing both VHDL and Verilog files. Mixing VHDL and Verilog is restricted to design unit (cell) instantiation only. A VHDL design can instantiate a Verilog module, and a Verilog design can instantiate a VHDL entity.

Since VHDL and Verilog have different features, it is important to follow the rules for creating mixed language projects, including:

- Case sensitivity
- Instantiating a VHDL design unit in a Verilog design
- Instantiating a Verilog module in a VHDL design
- Permitted data types
- Using generics and parameters

Synthesis tools may differ in mixed language support.

For more information, see your synthesis tool documentation.

If Statements and Case Statements

Most synthesis tools can determine whether the **if-elsif** conditions are mutually exclusive, and do not create extra logic to build the priority tree.

When writing **if** statements:

- Make sure that all outputs are defined in all branches of an **if** statement. If not, it can create latches or long equations on the **CE** signal. To prevent this, specify default values for all outputs before the **if** statements.
- Remember that limiting the input signals into an **if** statement can reduce the number of logic levels. If there are a large number of input signals, determine whether some can be pre-decoded and registered before the **if** statement.
- Avoid bringing the dataflow into a complex **if** statement. Only control signals should be generated in complex **if-elsif** statements.

Comparison of If Statements and Case Statements

If Statement	Case Statement
Creates priority-encoded logic	Creates balanced logic
Can contain a set of different expressions	Evaluated against a common controlling expression
Use for speed critical paths	Use for complex decoding

4-to-1 Multiplexer Design With If Statement Coding Examples

The following coding examples use an **if** statement in a 4-to-1 multiplexer design.

4-to-1 Multiplexer Design With If Statement VHDL Coding Example

```
-- IF_EX.VHD
library IEEE;
use IEEE.std_logic_1164.all;
use IEEE.std_logic_unsigned.all;
entity if_ex is
    port (
        SEL: in STD_LOGIC_VECTOR(1 downto 0);
        A,B,C,D: in STD_LOGIC;
        MUX_OUT: out STD_LOGIC);
end if_ex;
architecture BEHAV of if_ex is
begin
    IF_PRO: process (SEL,A,B,C,D)
    begin
        if (SEL="00") then MUX_OUT <= A;
        elsif (SEL="01") then
            MUX_OUT <= B;
        elsif (SEL="10") then
            MUX_OUT <= C;
        elsif (SEL="11") then
            MUX_OUT <= D;
        else
            MUX_OUT <= '0';
        end if;
    end process; --END IF_PRO
end BEHAV;
```

4-to-1 Multiplexer Design With If Statement Verilog Coding Example

```
////////////////////////////////////
// IF_EX.V //
// Example of a if statement showing a //
// mux created using priority encoded logic //
// HDL Synthesis Design Guide for FPGA devices //
////////////////////////////////////
module if_ex (
    input A, B, C, D,
    input [1:0] SEL,
    output reg MUX_OUT);
always @ (*)
    begin
        if (SEL == 2'b00)
            MUX_OUT = A;
        else if (SEL == 2'b01)
            MUX_OUT = B;
        else if (SEL == 2'b10)
            MUX_OUT = C;
        else if (SEL == 2'b11)
            MUX_OUT = D;
        else
            MUX_OUT = 0;
        end
    endmodule
```

4-to-1 Multiplexer Design With Case Statement Coding Examples

The following coding examples use a **case** statement for the same multiplexer.

In these examples, the **case** statement requires only one slice, while the **if** statement requires two slices in some synthesis tools. In this instance, design the multiplexer using the **case** statement. Fewer resources are used and the delay path is shorter. When writing **case** statements, make sure all outputs are defined in all branches.

The Case_Ex Implementation diagram below shows the implementation of these designs.

4-to-1 Multiplexer Design With Case Statement VHDL Coding Example

```
-- CASE_EX.VHD
-- May 2009
library IEEE;
use IEEE.std_logic_1164.all;
use IEEE.std_logic_unsigned.all;
entity case_ex is
    port (
        SEL : in STD_LOGIC_VECTOR(1 downto 0);
        A,B,C,D: in STD_LOGIC;
        MUX_OUT: out STD_LOGIC);
end case_ex;
architecture BEHAV of case_ex is
begin
    CASE_PRO: process (SEL,A,B,C,D)
    begin
        case SEL is
            when "00" => MUX_OUT <= A;
            when "01" => MUX_OUT <= B;
            when "10" => MUX_OUT <= C;
            when "11" => MUX_OUT <= D;
            when others => MUX_OUT <= '0';
        end case;
    end process; --End CASE_PRO
end BEHAV;
```

4-to-1 Multiplexer Design With Case Statement Verilog Coding Example

```
////////////////////////////////////
// CASE_EX.V //
// Example of a Case statement showing //
// A mux created using parallel logic //
// HDL Synthesis Design Guide for FPGA devices //
////////////////////////////////////
module case_ex (
    input A, B, C, D,
    input [1:0] SEL,
    output reg MUX_OUT);

always @ (*)
begin
    case (SEL)
        2'b00: MUX_OUT = A;
        2'b01: MUX_OUT = B;
        2'b10: MUX_OUT = C;
        2'b11: MUX_OUT = D;
        default: MUX_OUT = 0;
    endcase
end
endmodule
```

Case_Ex Implementation Diagram

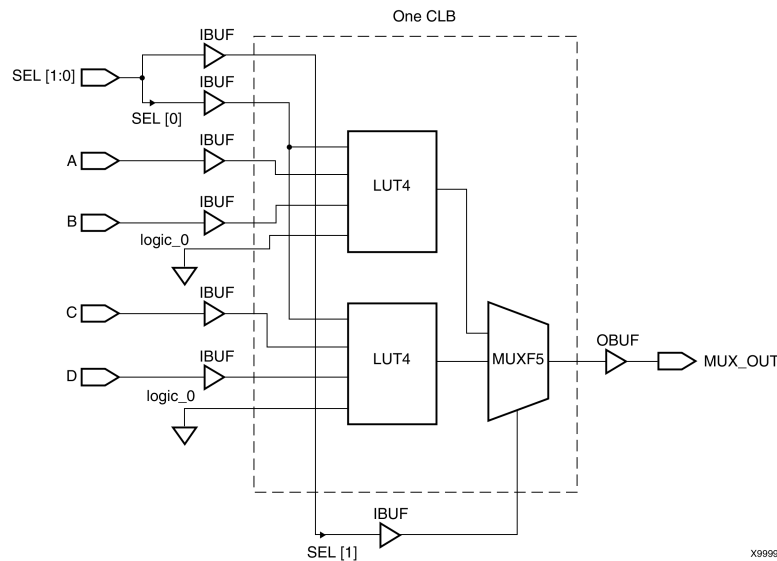

Sensitivity List in Process and Always Statements

A sensitivity list in a process statement (VHDL) or always block (Verilog) is a list of signals to which the process statement (VHDL) or always block (Verilog) is sensitive. When any of the listed signals changes its value, the process statement (VHDL) or always block (Verilog) resumes and executes its statements. Depending on the sensitivity list and set of statements, the process statement (VHDL) or always block (Verilog) can describe sequential elements as flip-flops and latches or combinatorial elements, or a mix of them.

When working with sensitivity lists, be sure to specify all necessary signals. If you do not do so, hardware generated from the Hardware Description Language (HDL) code may behave differently as compared to the Register Transfer Level (RTL) description. This behavior arises from the synthesis tool for the following reasons:

- In some cases, it is impossible to model the RTL description using existing hardware.
- The HDL code requires additional logic in the final implementation in order to exactly model the RTL description.

In order to avoid these two problems, synthesis may assume that the sensitivity list contains other signals which were not explicitly listed in the HDL code. As a result, while you will get the hardware you intended, the RTL and post-synthesis simulation will differ. In this case, some synthesis tools may issue a message warning of an incomplete sensitivity list. In that event, check the synthesis log file and, if necessary, fix the RTL code.

The following example describes a simple AND function using a process and always block. The sensitivity list is complete and a single LUT is generated.

VHDL Process Coding Example One

```
process (a,b)
begin
    c <= a and b;
end process;
```

Verilog Always Block Coding Example One

```
always @(a or b)
    c <= a & b;
```

The following examples are based on the previous two coding examples, but signal **b** is omitted from the sensitivity list. In this case, the synthesis tool assumes the presence of **b** in the sensitivity list and still generates the combinatorial logic (**AND** function).

VHDL Process Coding Example Two

```
process (a)
begin
    c <= a and b;
end process;
```

Verilog Always Block Coding Example Two

```
always @(a)
    c <= a & b;
```

Delays in Synthesis Code

Do not use **wait for XX ns** (VHDL) or the **#XX** (Verilog) statements in your code. **XX** specifies the number of nanoseconds that must pass before a condition is executed. This statement does not synthesize to a component. In designs that include this construct, the functionality of the *simulated* design does not always match the functionality of the *synthesized* design.

Wait for XX ns Statement VHDL Coding Example

```
wait for XX ns;
```

Wait for XX ns Statement Verilog Coding Example

```
#XX;
```

Do not use the **After XX ns** statement in your VHDL code or the Delay assignment in your Verilog code.

After XX ns Statement VHDL Coding Example

```
(Q <=0 after XX ns)
```

Delay Assignment Verilog Coding Example

```
assign #XX Q=0;
```

XX specifies the number of nanoseconds that must pass before a condition is executed. This statement is usually ignored by the synthesis tool. In this case, the functionality of the *simulated* design does not match the functionality of the *synthesized* design.

Registers in FPGA Design

Xilinx® FPGA devices have abundant flip-flops. FPGA architectures support flip-flops with the following control signals:

- Clock Enable
- Asynchronous Set/Reset
- Synchronous Set/Reset

All synthesis tools targeting Xilinx FPGA devices are capable to infer registers with all mentioned above control signals. For more information on control signal usage in FPGA design, see [Control Signals](#).

In addition, the value of a flip-flop at device start-up can be set to a logical value 0 or 1. This is known as the initialization state, or **INIT**.

Flip-Flop with Positive Edge Clock VHDL Coding Example

```
process (C)
begin
    if (C'event and C='1') then
        Q <= D;
    end if;
end process;
```

Flip-Flop with Positive Edge Clock Verilog Coding Example

```
always @(posedge C)
begin
    Q <= D;
end
```

Flip-Flop with Positive Edge Clock and Clock Enable VHDL Coding Example

```
process (C)
begin
    if (C'event and C='1') then
        if (CE='1') then
            Q <= D;
        end if;
    end if;
end process;
```

Flip-Flop with Positive Edge Clock and Clock Enable Verilog Coding Example

```
always @(posedge C)
begin
    if (CE)
        Q <= D;
    end
```

Flip-Flop with Negative Edge Clock and Asynchronous Reset VHDL Coding Example

```
process (C, CLR)
begin
    if (CLR = '1')then
        Q <= '0';
    elsif (C'event and C='0')then
        Q <= D;
    end if;
end process;
```

Flip-Flop with Negative Edge Clock and Asynchronous Reset Verilog Coding Example

```
always @(negedge C or posedge CLR)
begin
    if (CLR)
        Q <= 1'b0;
    else
        Q <= D;
end
```

Flip-Flop with Positive Edge Clock and Synchronous Set VHDL Coding Example

```
process (C)
begin
    if (C'event and C='1') then
        if (S='1') then
            Q <= '1';
        else
            Q <= D;
        end if;
    end if;
end process;
```

Flip-Flop with Positive Edge Clock and Synchronous Set Verilog Coding Example

```
always @(posedge C)
begin
    if (S)
        Q <= 1'b1;
    else
        Q <= D;
end
```

Input Output Block (IOB) Registers

An Input Output Block (IOB) contains several storage elements that can be configured as regular flip-flops or, depending on the FPGA family, as Dual-Data Rate (DDR) registers.

All flip-flops that are to be pushed into the **IOB** must have a fanout of **1**. This applies to output and tristate enable registers. For example, for a 32-bit bidirectional bus, the tristate enable signal must be replicated in the original design so that it has a fanout of **1**.

In order to push flip-flops to **IOBs**, you may use the following methods:

- Use a synthesis specific constraint
- Apply the **IOB=TRUE** constraint in the User Constraints File (UCF)
- Use the **-pr** command line option in **map**

Synthesis tools may automatically push flip-flops to IOBs.

For more information, see your synthesis tool documentation.

Dual-Data Rate (DDR) Registers

In order to take advantage of Dual-Data Rate (DDR) registers, you must instantiate the corresponding UNISIM primitives. However, some synthesis tools are able to infer DDR registers directly from the Hardware Description Language (HDL) code.

For more information, see your synthesis tool documentation.

Dual-Data Rate (DDR) Input Output Block (IOB) Registers VHDL Coding Example

```
library ieee;
use ieee.std_logic_1164.all;
entity ddr_input is
port ( clk : in std_logic;
      d : in std_logic;
      rst : in std_logic;
      q1 : out std_logic;
      q2 : out std_logic
      );
end ddr_input;

architecture behavioral of ddr_input is
begin
  q1reg : process (clk, rst)
  begin
    if rst = '1' then
      q1 <= '0';
    elsif clk'event and clk='1' then
      q1 <= d;
    end if;
  end process;

  q2reg : process (clk, rst)
  begin
    if rst = '1' then
      q2 <= '0';
    elsif clk'event and clk='0' then
      q2 <= d;
    end if;
  end process;
end behavioral;
```

Dual-Data Rate (DDR) Input Output Block (IOB) Registers Verilog Coding Example

```
module ddr_input (
    input data_in, clk, rst,
    output data_out);

    reg q1, q2;

    always @ (posedge clk, posedge rst)
    begin
        if (rst)
            q1 <=1'b0;
        else
            q1 <= data_in;
    end

    always @ (negedge clk, posedge rst)
    begin
        if (rst)
            q2 <=1'b0;
        else
            q2 <= data_in;
    end
    assign data_out = q1 & q2;
end module
```

Latches in FPGA Design

Synthesizers infer latches from incomplete conditional expressions, such as:

- An **if** statement without an **else** clause
- An intended register without a rising edge or falling edge construct

If Statement Without an else Clause VHDL Coding Example

```
process (G, D)
begin
    if (G='1') then
        Q <= D;
    end if;
end process;
```

If Statement Without an else Clause Verilog Coding Example

```
always @(G or D)
begin
    if (G)
        Q = D;
    end
end
```

Many times this is done by mistake. The design may still appear to function properly in simulation. This can be problematic for FPGA designs, since timing for paths containing latches can be difficult to analyze. Synthesis tools usually report in the log files when a latch is inferred to alert you to this occurrence.

Xilinx® recommends that you avoid using latches in FPGA designs, due to the more difficult timing analyses that take place when latches are used.

Some synthesis tools can determine the number of latches in your design.

For more information, see your synthesis tool documentation.

You should convert all **if** statements without corresponding **else** statements and without a clock edge to registers or logic gates. Use the recommended coding styles in the synthesis tool documentation to complete this conversion.

Implementing Shift Registers

In general, a shift register is characterized by the following control and data signals:

- Clock
- Serial input
- Asynchronous set/reset
- Synchronous set/reset
- Synchronous/asynchronous parallel load
- Clock enable
- Serial or parallel output

The shift register output mode may be:

- Serial

Only the contents of the last flip-flop are accessed by the rest of the circuit

- Parallel

The contents of one or several flip-flops, other than the last one, are accessed as Shift modes: for example, left, right.

Xilinx® FPGA devices contain dedicated **SRL16** and **SRL32** resources (integrated in **LUTs**) allowing efficiently implement shift registers without using flip-flop resources. However these elements support only **LEFT** shift operations, and have a limited number of **IO** signals:

- Clock
- Clock Enable
- Serial Data In
- Serial Data Out

In addition, **SRLs** have address inputs (**LUT A3, A2, A1, A0** inputs for **SRL16**) determining the length of the shift register. The shift register may be of a fixed, static length, or it may be dynamically adjusted. In dynamic mode each time a new address is applied to the address pins, the new bit position value is available on the Q output after the time delay to access the **LUT**.

As mentioned before, Synchronous and Asynchronous set/reset control signals are not available in the **SLRs** primitives. However some synthesis tools are able to take advantage of dedicated **SRL** resources and propose implementation allowing a significant area savings.

For more information, see your synthesis tool documentation.

Describing Shift Registers

There are several ways to describe shift registers in VHDL:

- Concatenation Operators

```
shreg <= shreg (6 downto 0) & SI;
```

- **for loop** constructs

```
for i in 0 to 6 loop
shreg(i+1) <= shreg(i);
end loop;
shreg(0) <= SI;
```

- Predefined shift operators

For example, **SLL** or **SRL**

8-Bit Shift-Left Register Serial In and Serial Out VHDL Coding Example

```
library ieee;
use ieee.std_logic_1164.all;

entity shift_regs_1 is
    port(C, SI : in std_logic;
         SO : out std_logic);
end shift_regs_1;

architecture archi of shift_regs_1 is
    signal tmp: std_logic_vector(7 downto 0);
begin

    process (C)
    begin
        if (C'event and C='1') then
            tmp <= tmp(6 downto 0) & SI;
        end if;
    end process;

    SO <= tmp(7);

end archi;
```

8-Bit Shift-Left Register Serial In and Serial Out Verilog Coding Example

```
module v_shift_regs_1 (C, SI, SO);
    input C,SI;
    output SO;
    reg [7:0] tmp;

    always @(posedge C)
    begin
        tmp = {tmp[6:0], SI};
    end

    assign SO = tmp[7];

endmodule
```

16-Bit Dynamic Shift Register With Serial In and Serial Out VHDL Coding Example

```

library IEEE;
use IEEE.std_logic_1164.all;
use IEEE.std_logic_unsigned.all;

entity dynamic_shift_regs_1 is
    port(CLK : in std_logic;
         DATA : in std_logic;
         CE : in std_logic;
         A : in std_logic_vector(3 downto 0);
         Q : out std_logic);
end dynamic_shift_regs_1;

architecture rtl of dynamic_shift_regs_1 is
    constant DEPTH_WIDTH : integer := 16;

    type SRL_ARRAY is array (0 to DEPTH_WIDTH-1) of std_logic;
    -- The type SRL_ARRAY can be array
    -- (0 to DEPTH_WIDTH-1) of
    -- std_logic_vector(BUS_WIDTH downto 0)
    -- or array (DEPTH_WIDTH-1 downto 0) of
    -- std_logic_vector(BUS_WIDTH downto 0)
    -- (the subtype is forward (see below))
    signal SRL_SIG : SRL_ARRAY;

begin
    PROC_SRL16 : process (CLK)
    begin
        if (CLK'event and CLK = '1') then
            if (CE = '1') then
                SRL_SIG <= DATA & SRL_SIG(0 to DEPTH_WIDTH-2);
            end if;
        end if;
    end process;

    Q <= SRL_SIG(conv_integer(A));

end rtl;

```

16-Bit Dynamic Shift Register With Serial In and Serial Out Verilog Coding Example

```

module v_dynamic_shift_regs_1 (Q,CE,CLK,D,A);
    input CLK, D, CE;
    input [3:0] A;
    output Q;
    reg [15:0] data;

    assign Q = data[A];

    always @(posedge CLK)
    begin
        if (CE == 1'b1)
            data <= {data[14:0], D};
    end

endmodule

```

Control Signals

This section discusses Control Signals, and includes:

- [Set, Resets, and Synthesis Optimization](#)
- [Using Clock Enable Pin Instead of Gated Clocks](#)
- [Converting the Gated Clock to a Clock Enable](#)

Set, Resets, and Synthesis Optimization

Xilinx® FPGA devices have abundant flip-flops. All architectures support an asynchronous reset for those registers and latches. Even though this capability exists, Xilinx does not recommend that you code for it. Using asynchronous resets may result in:

- More difficult timing analysis
- Less optimal optimization by the synthesis tool

The timing hazard which an asynchronous reset poses on a synchronous system is well known. Less well known is the optimization trade-off which the asynchronous reset poses on a design.

Global Set/Reset (GSR)

All Xilinx FPGA devices have a dedicated asynchronous reset called Global Set/Reset (GSR). GSR is automatically asserted at the end of FPGA configuration, regardless of the design. For gate-level simulation, this GSR signal is also inserted to mimic this operation to allow accurate simulation of the initialized design as it happens in the silicon. Adding another asynchronous reset to the actual code only duplicates this dedicated feature. It is not necessary for device initialization or simulation initialization.

Shift Register LUT (SRL)

FPGA devices contain LUTs that may be configured to act as a 16-bit shift register called a Shift Register LUT (SRL). Using any reset when inferring shift registers prohibits the inference of the **SRL**.

The **SRL** is an efficient structure for building static and variable length shift registers. A reset (either synchronous or asynchronous) would preclude using this component. This generally leads to a less efficient structure using a combination of registers and, sometimes, logic.

Synchronous and Asynchronous Resets

The choice between synchronous and asynchronous resets can also change the choices of how registers are used within larger IP blocks. For instance, DSP48 in Virtex®-4 devices and Virtex-5 devices has several registers within the block which, if used, may result in a substantial area savings, as well as improve overall circuit performance.

DSP48 has only a synchronous reset. If a synchronous reset is inferred in registers around logic that could be packed into a DSP48, the registers can also be packed into the component, resulting in a smaller and faster design. If an asynchronous reset is used, the register must remain outside the block, resulting in a less optimal design. Similar optimization applies to the block RAM registers and other components within the FPGA device.

The flip-flops within the FPGA device are configurable to be either an asynchronous set/reset, or a synchronous set/reset. If an asynchronous reset is described in the code, the synthesis tool must configure the flip-flop to use the asynchronous set/reset. This precludes the using any other signals using this resource.

If a synchronous reset (or no reset at all) is described for the flip-flop, the synthesis tool can configure the set/reset as a synchronous operation. Doing so allows the synthesis tool to use this resource as a set/reset from the described code. It may also use this resource to break up the data path. This may result in fewer resources and shorter data paths to the register. Details of these optimizations depend on the code and synthesis tools used.

Asynchronous Resets Coding Examples

This section gives *asynchronous* resets coding examples. For the same code re-written for *synchronous* resets, see [Synchronous Resets Coding Examples](#).

Asynchronous Resets VHDL Coding Example

```
process (CLK, RST)
begin
  if (RST = '1') then
    Q <= '0';
  elsif (CLK'event and CLK = '1') then
    Q <= A or (B and C and D and E);
  end if;
end process;
```

Asynchronous Resets Verilog Coding Example

To implement the following code, the synthesis tool must infer two LUTs for the data path, since five signals were used to create this logic

```
always @(posedge CLK or posedge RST)
  if (RST)
    Q <= 1'b0;
  else
    Q <= A | (B & C & D & E);
```

For a possible implementation of this code, see the following diagram.

Asynchronous Resets Verilog Coding Example Diagram

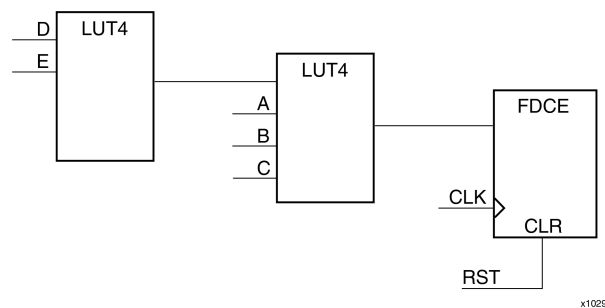

Synchronous Resets Coding Examples

For the code shown under [Asynchronous Resets Coding Examples](#) re-written for synchronous reset, see the following synchronous resets coding examples.

Synchronous Resets VHDL Coding Example One

```

process (CLK)
begin
  if (CLK'event and CLK = '1') then
    if (RST = '1') then
      Q <= '0';
    else
      Q <= A or (B and C and D and E);
    end if;
  end if;
end process;

```

Synchronous Resets Verilog Coding Example One

```

always @(posedge CLK)
  if (RST)
    Q <= 1'b0;
  else
    Q <= A | (B & C & D & E);

```

The synthesis tool now has more flexibility as to how this function can be represented. For a possible implementation of this code, see the following diagram.

In this implementation, the synthesis tool can identify that any time A is active high, Q is always a logic one. With the register now configured with the set/reset as a synchronous operation, the set is now free to be used as part of the synchronous data path. This reduces:

- The amount of logic necessary to implement the function
- The data path delays for the D and E signals

Logic could have also been shifted to the reset side as well if the code was written in a way that was a more beneficial implementation

Synchronous Resets Verilog Coding Example One Diagram

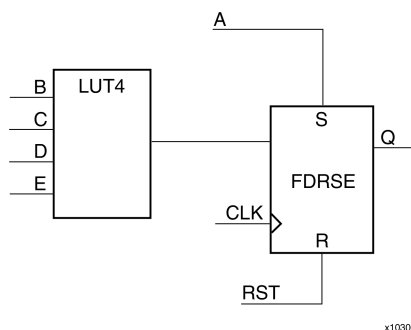

Synchronous Resets VHDL Coding Example Two

Now consider the following addition to the example shown in Synchronous Resets VHDL Coding Example One.

```
process (CLK, RST)
begin
  if (RST = '1') then
    Q <= '0';
  elsif (CLK'event and CLK = '1') then
    Q <= (F or G or H) and (A or (B and C and D and E));
  end if;
end process;
```

Synchronous Resets Verilog Coding Example Two

```
always @(posedge CLK or posedge RST)
  if (RST)
    Q <= 1'b0;
  else
    Q <= (F | G | H) & (A | (B & C & D & E));
```

Since eight signals now contribute to the logic function, a minimum of three LUTs are needed to implement this function. For a possible implementation of this code, see the following diagram.

Synchronous Resets Verilog Coding Example Two Diagram

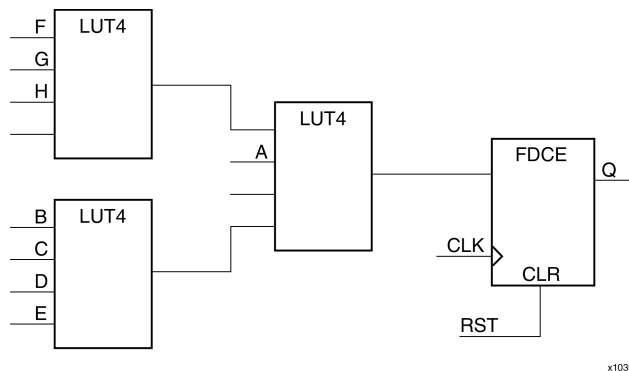

Synchronous Resets VHDL Coding Example Three

If the same code is written with a synchronous reset:

```
process (CLK)
begin
  if (CLK'event and CLK = '1') then
    if (RST = '1') then
      Q <= '0';
    else
      Q <= (F or G or H) and (A or (B and C and D and E));
    end if;
  end if;
end process;
```

Synchronous Resets Verilog Coding Example Three

```
always @(posedge CLK)
  if (RST)
    Q <= 1'b0;
  else
    Q <= (F | G | H) & (A | (B & C & D & E));
```

For a possible implementation of this code, see the following diagram.

The resulting implementation not only uses fewer LUTs to implement the same logic function, but may result in a faster design due to the reduction of logic levels for nearly every signal that creates this function. While these are simple examples, they do show how asynchronous resets force all synchronous data signals on the data input to the register, resulting in a potentially less optimal implementation.

In general, the more signals that fan into a logic function, the more effective using synchronous sets/resets (or no resets at all) can be in minimizing logic resources and in maximizing design performance.

Synchronous Resets Verilog Coding Example Three Diagram

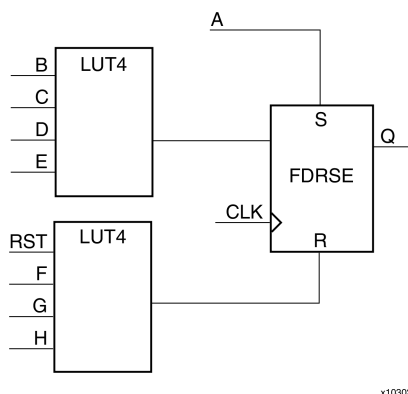

Using Clock Enable Pin Instead of Gated Clocks

Xilinx® recommends that you use the **CLB** clock enable pin instead of gated clocks. Gated clocks can cause glitches, increased clock delay, clock skew, and other undesirable effects. Using **clock enable** saves clock resources, and can improve timing characteristic and analysis of the design.

If you want to use a gated clock for power reduction, most FPGA devices now have a clock enabled global buffer resource called **BUFGCE**. However, a clock enable is still the preferred method to reduce or stop the clock to portions of the design.

Gated Clock VHDL Coding Example

```
-- The following code is for demonstration purposes only
-- Xilinx does not suggest using the following coding style in FPGAs
library IEEE;
use IEEE.std_logic_1164.all;
use IEEE.std_logic_unsigned.all;
entity gate_clock is
    port (DATA, IN1, IN2, LOAD, CLOCK: in STD_LOGIC;
          OUT1: out STD_LOGIC);
end gate_clock;
architecture BEHAVIORAL of gate_clock is
    signal GATECLK: STD_LOGIC;
begin
    GATECLK <= (IN1 and IN2 and LOAD and CLOCK);
    GATE_PR: process (GATECLK)
    begin
        if (GATECLK'event and GATECLK='1') then
            OUT1 <= DATA;
        end if;
    end process; -- End GATE_PR
end BEHAVIORAL;
```

Gated Clock Verilog Coding Example

```
// The following code is for demonstration purposes only
// Xilinx does not suggest using the following coding style in FPGAs
module gate_clock(
    input DATA, IN1, IN2, LOAD, CLOCK,
    output reg OUT1
);
    wire GATECLK;
    assign GATECLK = (IN1 & IN2 & LOAD & CLOCK);
    always @(posedge GATECLK)
        OUT1 <= DATA;
endmodule
```

Converting the Gated Clock to a Clock Enable

This section contains VHDL and Verilog coding examples for converting the gated clock to a clock enable.

Clock Enable VHDL Coding Example

```

library IEEE;
use IEEE.std_logic_1164.all;
use IEEE.std_logic_unsigned.all;
entity clock_enable is
    port (DATA, IN1, IN2, LOAD, CLOCK: in STD_LOGIC;
          OUT1: out STD_LOGIC);
end clock_enable;
architecture BEHAVIORAL of clock_enable is
    signal ENABLE: std_logic;
begin
    ENABLE <= IN1 and IN2 and LOAD;
    EN_PR: process (CLOCK)
    begin
        if (CLOCK'event and CLOCK='1') then
            if (ENABLE = '1') then
                OUT1 <= DATA;
            end if;
        end if;
    end process;
end BEHAVIORAL;

```

Clock Enable Verilog Coding Example

```

module clock_enable (
    input DATA, IN1, IN2, LOAD, CLOCK,
    output reg OUT1
);
    wire ENABLE;

    assign ENABLE = (IN1 & IN2 & LOAD);
    always @(posedge CLOCK)
        if (ENABLE)
            OUT1 <= DATA;
endmodule

```

Implementation of Clock Enable Diagram

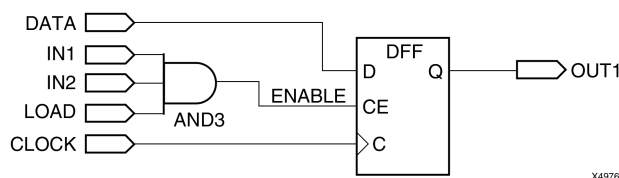

Initial State of the Registers and Latches

FPGA flip-flops are configured as either preset (asynchronous set) or clear (asynchronous reset) during startup. This is known as the initialization state, or **INIT**. The initial state of the register can be specified as follows:

- If the register is instantiated, it can be specified by setting the **INIT** generic/parameter value to either a **1** or **0**, depending on the desired state. For more information, see the *Libraries Guides*.
- If the register is inferred, the initial state can be specified by initializing the VHDL signal declaration or the Verilog reg declaration as shown in the following coding examples.

Initial State of the Registers and Latches VHDL Coding Example One

```
signal register1 : std_logic := '0'; -- specifying register1 to start as a zero
signal register2 : std_logic := '1'; -- specifying register2 to start as a one
signal register3 : std_logic_vector(3 downto 0):="1011"; -- specifying INIT value for 4-bit register
```

Initial State of the Registers and Latches Verilog Coding Example One

```
reg register1 = 1'b0; // specifying register1 to start as a zero
reg register2 = 1'b1; // specifying register2 to start as a one
reg [3:0] register3 = 4'b1011; //specifying INIT value for 4-bit register
```

Initial State of the Registers and Latches Verilog Coding Example Two

Another possibility in Verilog is to use an initial statement:

```
reg [3:0] register3;
initial begin
    register3= 4'b1011;
end
```

Not all synthesis tools support this initialization. To determine whether it is supported, see your synthesis tool documentation. If this initialization is not supported, or if it is not specified in the code, the initial value is determined by the presence or absence of an asynchronous preset in the code. If an asynchronous preset is present, the register initializes to a one. If an asynchronous preset is not present, the register initializes to a logic zero.

Initial State of the Shift Registers

The definition method of initial values for shift registers is the same used for Registers and Latches. For more information, see [Initial State of the Registers and Latches](#).

Initial State of the RAMs

The definition method of initial values for RAMs (block or distributed) is similar to the one used for Registers and Latches. The initial state of the RAM can be specified as follows:

- If the RAM is instantiated, it can be specified by setting the **INIT_00**, **INIT_01**, ... generic/parameter values, depending on the desired state. For more information, see the *Libraries Guides*.
- If the RAM is inferred, the initial state can be specified by initializing the VHDL signal declaration or using Verilog initial statement as shown in the following coding examples. The initial values could be specified directly in the HDL code, or in an external file containing the initialization data.

Initial State of the RAMs VHDL Coding Example

```
type ram_type is array (0 to 63) of std_logic_vector(19 downto 0);
signal RAM : ram_type :=(
    X"0200A", X"00300", X"08101", X"04000", X"08601", X"0233A",
    X"00300", X"08602", X"02310", X"0203B", X"08300", X"04002",
    X"08201", X"00500", ... );
```

Initial State of the RAMs Verilog Coding Example

```
reg [19:0] ram [63:0];
initial begin
    ram[63] = 20'h0200A; ram[62] = 20'h00300; ram[61] = 20'h08101;
    ram[60] = 20'h04000; ram[59] = 20'h08601; ram[58] = 20'h0233A;
    ...
    ram[2] = 20'h02341; ram[1] = 20'h08201; ram[0] = 20'h0400D;
end
```

Not all synthesis tools support this initialization. To determine whether it is supported, see your synthesis tool documentation.

Multiplexers

You can implement multiplexers on Xilinx® FPGA devices by using:

- Dedicated resources such as MUXF5, MUXF6 ...
- Using Carry chains
- LUTs only

The implementation choice is automatically taken by the synthesis tool and driven by speed or area design requirements. However some synthesis tools allow you to control the implementation style of multiplexers.

For more information, see your synthesis tool documentation.

There are different description styles for multiplexers (MUXs), such as **If-Then-Else** or **Case**. When writing MUXs, pay special attention in order to avoid common traps. For example, if you describe a MUX using a **Case** statement, and you do not specify all values of the selector, the result may be latches instead of a multiplexer.

Verilog **Case** statements can be:

- **full**
- **not full**

A **Case** statement is **full** if all possible branches are specified.

Verilog **Case** statements can also be:

- **parallel**
- **not parallel**

A **Case** statement is **parallel** if it does not contain branches that can be executed simultaneously.

Synthesis tools automatically determine the characteristics of the **Case** statements and generate corresponding logic. In addition they provide a way of allowing guide interpretation of **Case** statements by means of special directives.

For more information, see your synthesis tool documentation.

4-to-1 1-Bit MUX Using Case Statement VHDL Coding Example

```
library ieee;
use ieee.std_logic_1164.all;

entity multiplexers_2 is
    port (a, b, c, d : in std_logic;
          s : in std_logic_vector (1 downto 0);
          o : out std_logic);
end multiplexers_2;

architecture archi of multiplexers_2 is
begin
    process (a, b, c, d, s)
    begin
        case s is
            when "00" => o <= a;
            when "01" => o <= b;
            when "10" => o <= c;
            when others => o <= d;
        end case;
    end process;
end archi;
```

4-to-1 1-Bit MUX Using Case Statement Verilog Coding Example

```
module v_mults_2 (a, b, c, d, s, o);
    input a,b,c,d;
    input [1:0] s;
    output o;
    reg o;

    always @(a or b or c or d or s)
    begin
        case (s)
            2'b00 : o = a;
            2'b01 : o = b;
            2'b10 : o = c;
            default : o = d;
        endcase
    end
endmodule
```

4-to-1 1-Bit MUX Using IF Statement VHDL Coding Example

```
library ieee;
use ieee.std_logic_1164.all;

entity multiplexers_1 is
    port (a, b, c, d : in std_logic;
          s : in std_logic_vector (1 downto 0);
          o : out std_logic);
end multiplexers_1;

architecture archi of multiplexers_1 is
begin
    process (a, b, c, d, s)
    begin
        if (s = "00") then o <= a;
        elsif (s = "01") then o <= b;
        elsif (s = "10") then o <= c;
        else o <= d;
        end if;
    end process;
end archi;
```

4-to-1 1-Bit MUX Using IF Statement Verilog Coding Example

```
module v_mults_1 (a, b, c, d, s, o);
    input a,b,c,d;
    input [1:0] s;
    output o;
    reg o;

    always @(a or b or c or d or s)
    begin
        if (s == 2'b00) o = a;
        else if (s == 2'b01) o = b;
        else if (s == 2'b10) o = c;
        else o = d;
    end
endmodule
```

Finite State Machine (FSM) Components

This section discusses Finite State Machine (FSM) Components, and includes:

- [Finite State Machine \(FSM\) Description Style](#)
- [Finite State Machine \(FSM\) With One Process](#)
- [Finite State Machine \(FSM\) With Two or Three Processes](#)
- [Finite State Machine \(FSM\) Recognition and Optimization](#)
- [Other Finite State Machine \(FSM\) Features](#)

Finite State Machine (FSM) Description Style

Most FPGA synthesis tools propose a large set of templates to describe a Finite State Machine (FSM). There are many ways to describe FSM components. A traditional FSM representation incorporates Mealy and Moore machines, as shown in the following diagram.

Mealy and Moore Machines Diagram

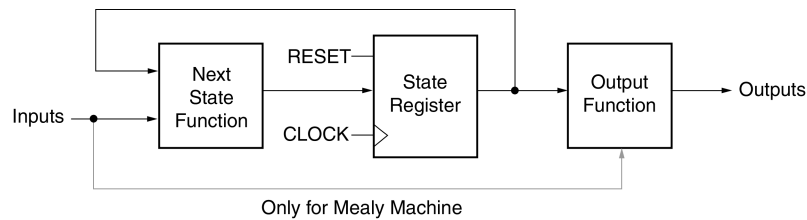

X10899

For a Hardware Description Language (HDL), *process* (VHDL) and *always blocks* (Verilog) are the best ways to describe FSM components. Xilinx® uses *process* to refer to both VHDL *processes* and Verilog *always blocks*.

You may have several processes (1, 2 or 3) in your description, consider and decompose the different parts of the preceding model.

The following example shows the Moore Machine with an Asynchronous Reset (RESET):

- 4 states: s1, s2, s3, s4
- 5 transitions
- 1 input: "x1"
- 1 output: "outp"

This model is represented by the following Bubble Diagram.

Bubble Diagram

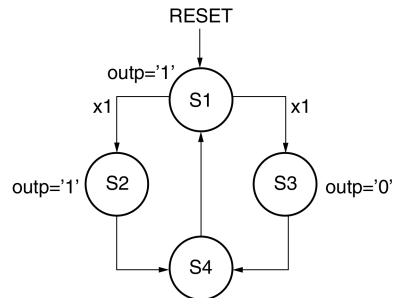

X10890

Finite State Machine (FSM) With One Process

In the following coding examples, output signal `outp` is a register.

Finite State Machine (FSM) With One Process VHDL Coding Example

```
---- State Machine with a single process.
--
library IEEE;
use IEEE.std_logic_1164.all;

entity fsm_1 is
  port ( clk, reset, x1 : IN std_logic;
        outp : OUT std_logic);
end entity;

architecture beh1 of fsm_1 is
  type state_type is (s1,s2,s3,s4);
  signal state: state_type ;

begin
  process (clk,reset)
  begin
    if (reset ='1') then
      state <=s1;
      outp<='1';
    elsif (clk='1' and clk'event) then
      case state is
        when s1 => if x1='1' then
                     state <= s2;
                     outp <= '1';
                   else
                     state <= s3;
                     outp <= '0';
                   end if;
        when s2 => state <= s4; outp <= '0';
        when s3 => state <= s4; outp <= '0';
        when s4 => state <= s1; outp <= '1';
      end case;
    end if;
  end process;
end beh1;
```

Finite State Machine (FSM) With a Single Always Block Verilog Coding Example

```
//
// State Machine with a single always block.
//
module v_fsm_1 (clk, reset, x1, outp);
    input clk, reset, x1;
    output outp;
    reg outp;
    reg [1:0] state;

    parameter s1 = 2'b00; parameter s2 = 2'b01;
    parameter s3 = 2'b10; parameter s4 = 2'b11;

    initial begin
        state = 2'b00;
    end

    always@(posedge clk or posedge reset)
    begin
        if (reset)
            begin
                state <= s1; outp <= 1'b1;
            end
        else
            begin
                case (state)
                    s1: begin
                        if (x1==1'b1)
                            begin
                                state <= s2;
                                outp <= 1'b1;
                            end
                        else
                            begin
                                state <= s3;
                                outp <= 1'b0;
                            end
                        end
                    s2: begin
                        state <= s4; outp <= 1'b1;
                    end
                    s3: begin
                        state <= s4; outp <= 1'b0;
                    end
                    s4: begin
                        state <= s1; outp <= 1'b0;
                    end
                endcase
            end
        end
    end
endmodule
```

In VHDL, the type of a state register can be a different type, such as:

- **integer**
- **bit_vector**
- **std_logic_vector**

Xilinx® recommends that you use an enumerated type containing all possible state values and to declare your state register with that type. This method was used in the previous VHDL Coding Example.

In Verilog, the type of state register can be an integer or a set of defined parameters. Xilinx recommends using a set of defined for state register definition. This method was used in the previous Verilog coding example.

Finite State Machine (FSM) With Two or Three Processes

A [Finite State Machine \(FSM\) With One Process](#) can be described with two processes using the FSM decomposition shown in the following diagram.

Finite State Machine (FSM) Using Two Processes Diagram

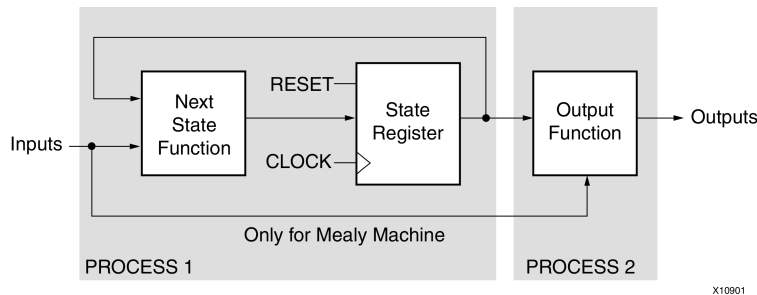

A [Finite State Machine \(FSM\) With One Process](#) can be described with three processes using the FSM decomposition shown in the following diagram.

Finite State Machine (FSM) Using Three Processes Diagram

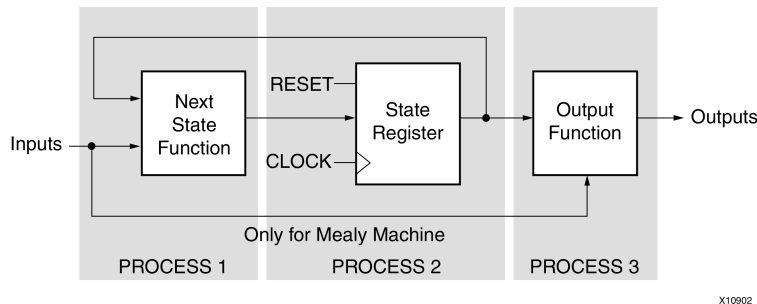

Finite State Machine (FSM) Recognition and Optimization

FPGA synthesis tools can automatically recognize Finite State Machine (FSM) components from HDL code and perform FSM dedicated optimization. Depending on your synthesis tool, recognizing an FSM may be conditioned by specific requirements, such as the presence of initialization on a state register.

For more information, see your synthesis tool documentation.

In general, in the default mode, a synthesis tries to search for the best encoding method for an FSM in order to reach best speed or smallest area. Many encoding methods such as One-Hot, Sequential or Gray methods are supported. In general, One-Hot encoding allows you to create state machine implementations that are efficient for FPGA architectures.

If are not satisfied with the automatic solution, you may force your synthesis tool to use a specific encoding method. Another possibility is to directly specify binary codes synthesis tool must apply for each state using specific synthesis constraints.

Other Finite State Machine (FSM) Features

Some synthesis tools offer additional Finite State Machine (FSM) related features, such as implementing Safe State machines, and implementing FSM components on BRAMs.

For more information, see your synthesis tool documentation.

Implementing Memory

Xilinx® FPGA devices provide two types of RAM:

- Distributed RAM (SelectRAM)
- Block RAM (Block SelectRAM)

There are three ways to incorporate RAM into a design:

- Use the automatic inference capability of the synthesis tool
- Use the CORE Generator™ software
- Instantiate dedicated elements from a UNISIM or UniMacro Library

Each of these methods has its advantages and disadvantages as shown in the following table.

Incorporating RAM into a Design

Method	Advantages	Disadvantages
Inference	<ul style="list-style-type: none"> • Most generic way to incorporate RAMs into the design, allowing easy/automatic design migration from one FPGA family to another • FAST simulation 	<ul style="list-style-type: none"> • Requires specific coding styles • Not all RAMs modes are supported • Gives you the least control over implementation
CORE Generator software	Gives more control over the RAM creation	<ul style="list-style-type: none"> • May complicate design migration from one FPGA family to another • Slower simulation comparing to Inference
Instantiation	Offers the most control over the implementation	<ul style="list-style-type: none"> • Limit and complicates design migration from one FPGA family to another • Requires multiple instantiations to properly create the right RAM configuration

Block and Distributed RAMs offer synchronous write capabilities. Read operation of the Block RAM is synchronous, while the distributed RAM can be configured for either asynchronous or synchronous reads.

In general, the selection of distributed RAM versus block RAM depends on the size of the RAM. If the RAM is not very deep, it is generally advantageous to use the distributed RAM. If you require a deeper RAM, it is generally more advantageous to use the block memory.

If a memory description can be implemented using Block and Distributed RAM resources, the synthesis tool automatically chooses how to implement RAM. This choice is driven by RAM size, speed, and area design requirements. If the automatic implementation choice does not meet your requirements, synthesis tools offer dedicated constraints allowing you to select the RAM type.

For more information, see your synthesis tool documentation.

Since all Xilinx RAMs have the ability to be initialized, the RAMs may also be configured either as a ROM (Read Only Memory), or as a RAM with pre-defined contents. Initialization of RAMs can be done directly from HDL code.

Some synthesis tools provide additional control over RAM inference and optimization process, such as pipelining, automatic Block RAM packing, and automatic Block RAM resource management.

For more information, see your synthesis tool documentation.

For additional information about Implementing Memory, see:

- [Block RAM Inference](#)
- [Distributed RAM Inference](#)

Block RAM Inference

Xilinx® Block RAMs are True Dual-Port Block resources. Each port is totally independent and can be configured with different depth and width. Read and write operations are synchronous. Block RAM resources offer different read/write synchronization modes:

- Read-First
- Write-First
- No-Change

FPGA device families such as Virtex®-5 devices offer additional enhancements, including:

- Cascadable Block RAMs
- Pipelined output registers
- Byte-Wide Write Enable

BRAM inference capabilities differ from one synthesis tool to another.

For more information, see your synthesis tool documentation.

The coding examples in this section show coding styles for the most frequently used Block RAM configurations, which are supported by most synthesis tools.

Single-Port RAM in Read-First Mode Pin Descriptions

IO Pins	Description
clk	Positive-Edge Clock
we	Synchronous Write Enable (Active High)
en	Clock Enable
addr	Read/Write Address
di	Data Input
do	Data Output

Single-Port RAM in Read-First Mode VHDL Coding Example

```

library ieee;
use ieee.std_logic_1164.all;
use ieee.std_logic_unsigned.all;

entity rams_01 is
    port (clk : in std_logic;
          we : in std_logic;
          en : in std_logic;
          addr : in std_logic_vector(5 downto 0);
          di : in std_logic_vector(15 downto 0);
          do : out std_logic_vector(15 downto 0));
end rams_01;

architecture syn of rams_01 is
    type ram_type is array (63 downto 0) of std_logic_vector (15 downto 0);
    signal RAM: ram_type;
begin
    process (clk)
    begin
        if clk'event and clk = '1' then
            if en = '1' then
                if we = '1' then
                    RAM(conv_integer(addr)) <= di;
                end if;
                do <= RAM(conv_integer(addr)) ;
            end if;
        end if;
    end process;
end syn;

```

Single-Port RAM in Read-First Mode Verilog Coding Example

```

module v_rams_01 (clk, en, we, addr, di, do);

    input  clk;
    input  we;
    input  en;
    input  [5:0] addr;
    input  [15:0] di;
    output [15:0] do;
    reg    [15:0] RAM [63:0];
    reg    [15:0] do;

    always @(posedge clk)
    begin
        if (en)
        begin
            if (we)
                RAM[addr]<=di;
            do <= RAM[addr];
        end
    end
endmodule

```

Single-Port RAM in Write-First Mode Pin Descriptions

IO Pins	Description
clk	Positive-Edge Clock
we	Synchronous Write Enable (Active High)
en	Clock Enable
addr	Read/Write Address
di	Data Input
do	Data Output

Single-Port RAM in Write-First Mode VHDL Coding Example One

```

library ieee;
use ieee.std_logic_1164.all;
use ieee.std_logic_unsigned.all;

entity rams_02a is
    port (clk : in std_logic;
          we  : in std_logic;
          en  : in std_logic;
          addr : in std_logic_vector(5 downto 0);
          di  : in std_logic_vector(15 downto 0);
          do  : out std_logic_vector(15 downto 0));
end rams_02a;

architecture syn of rams_02a is
    type ram_type is array (63 downto 0)
        of std_logic_vector (15 downto 0);
    signal RAM : ram_type;
begin

    process (clk)
    begin
        if clk'event and clk = '1' then
            if en = '1' then
                if we = '1' then
                    RAM(conv_integer(addr)) <= di;
                    do <= di;
                else
                    do <= RAM( conv_integer(addr));
                end if;
            end if;
        end if;
    end process;

end syn;

```

Single-Port RAM in Write-First Mode Verilog Coding Example One

```

module v_rams_02a (clk, we, en, addr, di, do);

    input  clk;
    input  we;
    input  en;
    input  [5:0] addr;
    input  [15:0] di;
    output [15:0] do;
    reg    [15:0] RAM [63:0];
    reg    [15:0] do;

    always @(posedge clk)
    begin
        if (en)
        begin
            if (we)
            begin
                RAM[addr] <= di;
                do <= di;
            end
            else
                do <= RAM[addr];
            end
        end
    end
endmodule

```

Single-Port RAM in Write-First Mode VHDL Coding Example Two

```

library ieee;
use ieee.std_logic_1164.all;
use ieee.std_logic_unsigned.all;

entity rams_02b is
port (clk : in std_logic;
      we  : in std_logic;
      en  : in std_logic;
      addr : in std_logic_vector(5 downto 0);
      di  : in std_logic_vector(15 downto 0);
      do  : out std_logic_vector(15 downto 0));
end rams_02b;

architecture syn of rams_02b is
    type ram_type is array (63 downto 0) of std_logic_vector (15 downto 0);
    signal RAM : ram_type;
    signal read_addr: std_logic_vector(5 downto 0);
begin
    process (clk)
    begin
        if clk'event and clk = '1' then
            if en = '1' then
                if we = '1' then
                    ram(conv_integer(addr)) <= di;
                end if;
                read_addr <= addr;
            end if;
        end if;
    end process;

    do <= ram(conv_integer(read_addr));
end syn;

```

Single-Port RAM in Write-First Mode Verilog Coding Example Two

```

module v_rams_02b (clk, we, en, addr, di, do);

    input  clk;
    input  we;
    input  en;
    input  [5:0] addr;
    input  [15:0] di;
    output [15:0] do;
    reg    [15:0] RAM [63:0];
    reg    [5:0] read_addr;

    always @(posedge clk)
    begin
        if (en)
        begin
            if (we)
                RAM[addr] <= di;
            read_addr <= addr;
        end
    end

    assign do = RAM[read_addr];

endmodule

```

Single-Port RAM In No-Change Mode Pin Descriptions

IO Pins	Description
clk	Positive-Edge Clock
we	Synchronous Write Enable (Active High)
en	Clock Enable
addr	Read/Write Address
di	Data Input
do	Data Output

Single-Port RAM In No-Change Mode VHDL Coding Example

```

library ieee;
use ieee.std_logic_1164.all;
use ieee.std_logic_unsigned.all;

entity rams_03 is
    port (clk : in std_logic;
          we : in std_logic;
          en : in std_logic;
          addr : in std_logic_vector(5 downto 0);
          di : in std_logic_vector(15 downto 0);
          do : out std_logic_vector(15 downto 0));
end rams_03;

architecture syn of rams_03 is
    type ram_type is array (63 downto 0) of std_logic_vector (15 downto 0);
    signal RAM : ram_type;
begin
    process (clk)
    begin
        if clk'event and clk = '1' then
            if en = '1' then
                if we = '1' then
                    RAM(conv_integer(addr)) <= di;
                else
                    do <= RAM( conv_integer(addr));
                end if;
            end if;
        end if;
    end process;
end syn;

```

Single-Port RAM In No-Change Mode Verilog Coding Example

```

module v_rams_03 (clk, we, en, addr, di, do);

    input  clk;
    input  we;
    input  en;
    input  [5:0] addr;
    input  [15:0] di;
    output [15:0] do;
    reg    [15:0] RAM [63:0];
    reg    [15:0] do;

    always @(posedge clk)
    begin
        if (en)
        begin
            if (we)
                RAM[addr] <= di;
            else
                do <= RAM[addr];
            end
        end
    end

endmodule

```

Dual-Port RAM in Read-First Mode With One Write Port Pin Descriptions

IO Pins	Description
clka, clkb	Positive-Edge Clock
ena	Primary Global Enable (Active High)
enb	Dual Global Enable (Active High)
wea	Primary Synchronous Write
addra	Write Address/Primary Read Address
addrb	Dual Read Address
dia	Primary Data Input
doa	Primary Output Port
dob	Dual Output Port

Dual-Port RAM in Read-First Mode with One Write Port VHDL Coding Example

```

library ieee;
use ieee.std_logic_1164.all;
use ieee.std_logic_unsigned.all;

entity rams_01_1 is
    port (clka, clkb    : in std_logic;
          wea          : in std_logic;
          ena, enb     : in std_logic;
          addra, addrb : in std_logic_vector(5 downto 0);
          dia          : in std_logic_vector(15 downto 0);
          doa, dob     : out std_logic_vector(15 downto 0));
end rams_01_1;

architecture syn of rams_01_1 is
    type ram_type is array (63 downto 0) of std_logic_vector (15 downto 0);
    signal RAM: ram_type;
begin

    process (clka)
    begin
        if clka'event and clka = '1' then
            if ena = '1' then
                if wea = '1' then
                    RAM(conv_integer(addra)) <= dia;
                end if;
                doa <= RAM(conv_integer(addra)) ;
            end if;
        end if;
    end process;

    process (clkb)
    begin
        if clkb'event and clkb = '1' then
            if enb = '1' then
                dob <= RAM(conv_integer(addrb)) ;
            end if;
        end if;
    end process;

end syn;

```

Dual-Port RAM in Read-First Mode with One Write Port Verilog Coding Example

```
module v_rams_01_1 (clk_a, clk_b, ena, enb, wea, addra, addrb, dia, doa, dob);

    input  clk_a, clk_b;
    input  wea;
    input  ena, enb;
    input  [5:0] addra, addrb;
    input  [15:0] dia;
    output [15:0] doa, dob;
    reg    [15:0] RAM [63:0];
    reg    [15:0] doa, dob;

    always @(posedge clk_a)
    begin
        if (ena)
            begin
                if (wea)
                    RAM[addra]<=dia;
                doa <= RAM[addra];
            end
        end

    always @(posedge clk_b)
    begin
        if (enb)
            begin
                dob <= RAM[addrb];
            end
        end
    end

endmodule
```

Dual-Port Block RAM in Read-First Mode With Two Write Ports

Some synthesis tools support dual-port block RAMs with two write ports for VHDL and Verilog. The concept of dual-write ports implies not only distinct data ports, but also the possibility of having distinct write clocks and write enables. Distinct write clocks also mean distinct read clocks, since the dual-port block RAM offers two clocks, one shared by the primary read and write port, the other shared by the secondary read and write port. In VHDL, the description of this type of block RAM is based on the usage of shared variables.

Because of the shared variable, the description of the different read/write synchronizations may be different from coding examples recommended for single-write RAMs. The order of appearance of the different lines of code is significant. In the next VHDL example describing read-first synchronization the read statement must come BEFORE the write statement.

Dual-Port Block RAM in Read-First Mode With Two Write Ports Pin Descriptions

IO Pins	Description
clka, clkb	Positive-Edge Clock
ena	Primary Global Enable (Active High)
enb	Dual Global Enable (Active High)
wea, web	Primary Synchronous Write Enable (Active High)
addra	Write Address/Primary Read Address
addrb	Dual Read Address
dia	Primary Data Input
dib	Dual Data Input
doa	Primary Output Port
dob	Dual Output Port

Dual-Port Block RAM in Read-First Mode With Two Write Ports VHDL Coding Example

```

library IEEE;
use IEEE.std_logic_1164.all;
use IEEE.std_logic_unsigned.all;

entity rams_16 is
  port(clka : in std_logic;
        clkb : in std_logic;
        ena  : in std_logic;
        enb  : in std_logic;
        wea  : in std_logic;
        web  : in std_logic;
        addra : in std_logic_vector(5 downto 0);
        addrb : in std_logic_vector(5 downto 0);
        dia  : in std_logic_vector(15 downto 0);
        dib  : in std_logic_vector(15 downto 0);
        doa  : out std_logic_vector(15 downto 0);
        dob  : out std_logic_vector(15 downto 0));
end rams_16;

architecture syn of rams_16 is
  type ram_type is array (63 downto 0) of std_logic_vector(15 downto 0);
  shared variable RAM : ram_type;
begin

  process (CLKA)
  begin
    if CLKA'event and CLKA = '1' then
      if ENA = '1' then
        DOA <= RAM(conv_integer(ADDRB));
        if WEA = '1' then
          RAM(conv_integer(ADDRB)) := DIA;
        end if;
      end if;
    end if;
  end process;

  process (CLKB)
  begin
    if CLKB'event and CLKB = '1' then
      if ENB = '1' then
        DOB <= RAM(conv_integer(ADDRB));
        if WEB = '1' then
          RAM(conv_integer(ADDRB)) := DIB;
        end if;
      end if;
    end if;
  end process;
end syn;

```

Dual-Port Block RAM in Read-First Mode With Two Write Ports Verilog Coding Example

```

module v_rams_16 (clka, clkb, ena, enb, wea, web, addra, addrb, dia, dib, doa, dob);

    input  clka, clkb, ena, enb, wea, web;
    input  [5:0]  addra, addrb;
    input  [15:0] dia, dib;
    output [15:0] doa, dob;
    reg    [15:0] ram [63:0];
    reg    [15:0] doa, dob;

    always @(posedge clka) begin
        if (ena)
            begin
                if (wea)
                    ram[addra] <= dia;
                doa <= ram[addra];
            end
        end
    end

    always @(posedge clkb) begin
        if (enb)
            begin
                if (web)
                    ram[addrb] <= dib;
                dob <= ram[addrb];
            end
        end
    end
endmodule

```

Distributed RAM Inference

The coding examples shown below provide coding styles for the most frequently used Distributed RAM configurations, which are supported by most synthesis tools.

Single-Port Distributed RAM Pin Descriptions

IO Pins	Description
clk	Positive-Edge Clock
we	Synchronous Write Enable (Active High)
a	Read/Write Address
di	Data Input
do	Data Output

Single-Port Distributed RAM VHDL Coding Example

```

library ieee;
use ieee.std_logic_1164.all;
use ieee.std_logic_unsigned.all;

entity rams_04 is
  port (clk : in std_logic;
        we  : in std_logic;
        a   : in std_logic_vector(5 downto 0);
        di  : in std_logic_vector(15 downto 0);
        do  : out std_logic_vector(15 downto 0));
end rams_04;

architecture syn of rams_04 is
  type ram_type is array (63 downto 0) of std_logic_vector (15 downto 0);
  signal RAM : ram_type;
begin

  process (clk)
  begin
    if (clk'event and clk = '1') then
      if (we = '1') then
        RAM(conv_integer(a)) <= di;
      end if;
    end if;
  end process;

  do <= RAM(conv_integer(a));

end syn;

```

Single-Port Distributed RAM Verilog Coding Example

```

module v_rams_04 (clk, we, a, di, do);

  input  clk;
  input  we;
  input  [5:0] a;
  input  [15:0] di;
  output [15:0] do;
  reg    [15:0] ram [63:0];

  always @(posedge clk) begin
    if (we)
      ram[a] <= di;
  end

  assign do = ram[a];

endmodule

```

Dual-Port Distributed RAM Pin Descriptions

IO Pins	Description
clk	Positive-Edge Clock
we	Synchronous Write Enable (Active High)
a	Write Address/Primary Read Address
dpra	Dual Read Address
di	Data Input
spo	Primary Output Port
dpo	Dual Output Port

Dual-Port Distributed RAM VHDL Coding Example

```

library ieee;
use ieee.std_logic_1164.all;
use ieee.std_logic_unsigned.all;

entity rams_09 is
  port (clk : in std_logic;
        we : in std_logic;
        a : in std_logic_vector(5 downto 0);
        dpra : in std_logic_vector(5 downto 0);
        di : in std_logic_vector(15 downto 0);
        spo : out std_logic_vector(15 downto 0);
        dpo : out std_logic_vector(15 downto 0));
end rams_09;

architecture syn of rams_09 is
  type ram_type is array (63 downto 0) of std_logic_vector (15 downto 0);
  signal RAM : ram_type;
begin

  process (clk)
  begin
    if (clk'event and clk = '1') then
      if (we = '1') then
        RAM(conv_integer(a)) <= di;
      end if;
    end if;
  end process;

  spo <= RAM(conv_integer(a));
  dpo <= RAM(conv_integer(dpra));

end syn;

```

Dual-Port Distributed RAM Verilog Coding Example

```

module v_rams_09 (clk, we, a, dpra, di, spo, dpo);

  input clk;
  input we;
  input [5:0] a;
  input [5:0] dpra;
  input [15:0] di;
  output [15:0] spo;
  output [15:0] dpo;
  reg [15:0] ram [63:0];

  always @(posedge clk) begin
    if (we)
      ram[a] <= di;
  end

  assign spo = ram[a];
  assign dpo = ram[dpra];

endmodule

```

Arithmetic Support

Xilinx® FPGA devices traditionally contain several hardware resources such as LUTs and Carry Chains. These hardware resources efficiently implement various arithmetic operations such as adders, subtractors, counters, accumulators, and comparators.

With the release of the Virtex®-4 device, Xilinx introduced a new primitive called DSP48. This block was further enhanced in later families such as Virtex-5 devices and Spartan®-3A DSP devices. DSP48 allows you to create numerous functions, including multipliers, adders, counters, barrel shifters, comparators, accumulators, multiply accumulate, complex multipliers, and others.

Currently, synthesis tools support the most important and frequently used DSP48 modes for DSP applications such as multipliers, adders/subtractors, multiply adders/subtractors, and multiply accumulate. The synthesis tools also take advantage of the internal registers available in DSP48, as well as the dynamic OPMODE port.

DSP48 fast connections allow you to efficiently build fast DSP48 chains as filters. These fast connections are automatically supported by synthesis tools today.

The level of DSP48 support may differ from one synthesis tool to another.

For more information, see your synthesis tool documentation.

Since there are several ways to implement the same arithmetic operation on the target device, synthesis tools make automatic choices depending on the operation type, size, context usage, or timing requirements. In some situations, the automatic choice may not meet your goals. Synthesis tools therefore offer several constraints to control implementation process such as `use_dsp48` in Xilinx Synthesis Technology (XST) or `syn_dspstyle` in Synplcity.

For more information, see your synthesis tool documentation.

If you migrate a design previously implemented using an older and FPGA device family to a newer one with a DSP48 block, and you want to take advantage of available DSP48 blocks, you must be aware of the following rules in order to get the best performance.

- DSP48 blocks give you the best performance when fully pipelined. You should add additional pipelining stages in order to get the best performance.
- Internal DSP48 registers support synchronous set and reset signals. Asynchronous set and reset signals are not supported. You must replace asynchronous initialization signals by synchronous ones. Some synthesis tools may automatically make this replacement. This operation renders the generated netlist NOT equivalent to the initial RTL description.

For more information, see your synthesis tool documentation.

- For DSP applications, use chain structures instead of tree structures in your RTL description in order to take full advantage of the DSP48 capabilities.

For more information on DSP48 blocks and specific DSP application coding style, see the [XtremeDSP™ User Guide](#) for your target family.

Unsigned 8-bit Adder VHDL Coding Example

```
library ieee;
use ieee.std_logic_1164.all;
use ieee.std_logic_unsigned.all;

entity arith_01 is
    port(A,B : in std_logic_vector(7 downto 0);
          SUM : out std_logic_vector(7 downto 0));
end arith_01;

architecture archi of arith_01 is
begin

    SUM <= A + B;

end archi;
```

Unsigned 8-bit Adder Verilog Coding Example

```
module v_arith_01(A, B, SUM);
    input [7:0] A;
    input [7:0] B;
    output [7:0] SUM;

    assign SUM = A + B;

Endmodule
```

Signed 8-bit Adder VHDL Coding Example

```
library ieee;
use ieee.std_logic_1164.all;
use ieee.std_logic_signed.all;

entity arith_02 is
    port(A,B : in std_logic_vector(7 downto 0);
         SUM : out std_logic_vector(7 downto 0));
end arith_02;

architecture archi of arith_02 is
begin

    SUM <= A + B;

end archi;
```

Signed 8-bit Adder Verilog Coding Example

```
module v_arith_02 (A,B,SUM);
    input signed [7:0] A;
    input signed [7:0] B;
    output signed [7:0] SUM;
    wire signed [7:0] SUM;

    assign SUM = A + B;

Endmodule
```

Unsigned 8-bit Adder with Registered Input/Outputs VHDL Coding Example

```

library ieee;
use ieee.std_logic_1164.all;
use ieee.std_logic_unsigned.all;

entity arith_03 is
    port(clk : in std_logic;
         A,B : in std_logic_vector(7 downto 0);
         SUM : out std_logic_vector(7 downto 0));
end arith_03;

architecture archi of arith_03 is
    signal reg_a, reg_b: std_logic_vector(7 downto 0);
begin
    process (clk)
    begin
        if (clk'event and clk='1') then
            reg_a <= A;
            reg_b <= B;
            SUM <= reg_a + reg_b;
        end if;
    end process;

end archi;

```

Unsigned 8-bit Adder with Registered Input/Outputs Verilog Coding Example

```

module v_arith_03 (clk, A, B, SUM);
    input    clk;
    input [7:0] A;
    input [7:0] B;
    output [7:0] SUM;

    reg [7:0] reg_a, reg_b, SUM;

    always @(posedge clk)
    begin
        reg_a <= A;
        reg_b <= B;
        SUM   <= reg_a + reg_b;
    end

endmodule

```

Unsigned 8-bit Adder/Subtractor VHDL Coding Example

```
library ieee;
use ieee.std_logic_1164.all;
use ieee.std_logic_unsigned.all;

entity arith_04 is
    port(A,B : in std_logic_vector(7 downto 0);
         OPER: in std_logic;
         RES : out std_logic_vector(7 downto 0));
end arith_04;

architecture archi of arith_04 is
begin

    RES <= A + B when OPER='0'
         else A - B;

end archi;
```

Unsigned 8-bit Adder/Subtractor Verilog Coding Example

```
module v_arith_04 (A, B, OPER, RES);
    input OPER;
    input [7:0] A;
    input [7:0] B;
    output [7:0] RES;
    reg [7:0] RES;

    always @(A or B or OPER)
    begin
        if (OPER==1'b0) RES = A + B;
        else RES = A - B;
    end

endmodule
```

Unsigned 8-Bit Greater or Equal Comparator VHDL Coding Example

```
library ieee;
use ieee.std_logic_1164.all;
use ieee.std_logic_unsigned.all;

entity arith_05 is
    port(A,B : in std_logic_vector(7 downto 0);
         CMP : out std_logic);
end arith_05;

architecture archi of arith_05 is
begin

    CMP <= '1' when A >= B else '0';

end archi;
```

Unsigned 8-Bit Greater or Equal Comparator Verilog Coding Example

```

module v_arith_05 (A, B, CMP);
    input  [7:0] A;
    input  [7:0] B;
    output CMP;

    assign CMP = (A >= B) ? 1'b1 : 1'b0;

endmodule

```

Unsigned 17x17-Bit Multiplier with Registered Input/Outputs VHDL Coding Example

```

library ieee;
use ieee.std_logic_1164.all;
use ieee.numeric_std.all;

entity arith_06 is
    port(clk : in std_logic;
         A : in unsigned (16 downto 0);
         B : in unsigned (16 downto 0);
         MULT : out unsigned (33 downto 0));
end arith_06;

architecture beh of arith_06 is
    signal reg_a, reg_b : unsigned (16 downto 0);

begin

    process (clk)
    begin
        if (clk'event and clk='1') then
            reg_a <= A; reg_b <= B;
            MULT <= reg_a * reg_b;
        end if;
    end process;

end beh;

```

Unsigned 17x17-Bit Multiplier with Registered Input/Outputs Verilog Coding Example

```

module v_arith_06(clk, A, B, MULT);

    input      clk;
    input  [16:0] A;
    input  [16:0] B;
    output [33:0] MULT;

    reg [33:0] MULT;
    reg [16:0] reg_a, reg_b;

    always @(posedge clk)
    begin
        reg_a <= A;
        reg_b <= B;
        MULT <= reg_a * reg_b;
    end
endmodule

```

Unsigned 8-Bit Up Counter with an Synchronous Reset VHDL Coding Example

```
library ieee;
use ieee.std_logic_1164.all;
use ieee.std_logic_unsigned.all;

entity arith_07 is
    port(clk, reset : in std_logic;
         Res : out std_logic_vector(7 downto 0));
end arith_07;

architecture archi of arith_07 is
    signal cnt: std_logic_vector(7 downto 0);
begin
    process (clk)
    begin
        if (clk'event and clk='1') then
            if (reset = '1') then
                cnt <= "00000000";
            else
                cnt <= cnt + 1;
            end if;
        end if;
    end process;

    Res <= cnt;

end archi;
```

Unsigned 8-Bit Up Counter with an Synchronous Reset Verilog Coding Example

```
module v_arith_07 (clk, reset, Res);
    input      clk, reset;
    output [7:0] Res;

    reg [7:0] cnt;

    always @(posedge clk)
    begin
        if (reset)
            cnt <= 8'b00000000;
        else
            cnt <= cnt + 1'b1;
        end

    assign Res = cnt;
endmodule
```

Unsigned 8-Bit Up Accumulator With Synchronous Reset VHDL Coding Example

```
library ieee;
use ieee.std_logic_1164.all;
use ieee.std_logic_unsigned.all;

entity arith_08 is
    port(clk, reset : in std_logic;
         din : in std_logic_vector(7 downto 0);
         Res : out std_logic_vector(7 downto 0));
end arith_08;

architecture archi of arith_08 is
    signal accu: std_logic_vector(7 downto 0);
begin
    process (clk)
    begin
        if (clk'event and clk='1') then
            if (reset = '1') then
                accu <= "00000000";
            else
                accu <= accu + din;
            end if;
        end if;
    end process;

    Res <= accu;

end archi;
```

Unsigned 8-Bit Up Accumulator With Synchronous Reset Verilog Coding Example

```
module v_arith_08 (clk, reset, din, Res);
    input      clk, reset;
    input  [7:0] din;
    output [7:0] Res;

    reg [7:0] accu;

    always @(posedge clk)
    begin
        if (reset)
            accu <= 8'b00000000;
        else
            accu <= accu + din;
        end
    end

    assign Res = accu;
endmodule
```

Multiplier Adder With 2 Register Levels on Multiplier Inputs, 1 Register Level after Multiplier and 1 Register Level after Adder VHDL Coding Example

```

library IEEE;
use IEEE.STD_LOGIC_1164.ALL;
use IEEE.STD_LOGIC_UNSIGNED.ALL;

entity arith_09 is
    generic (p_width: integer:=8);
    port (clk : in std_logic;
          A, B : in std_logic_vector(7 downto 0);
          C : in std_logic_vector(15 downto 0);
          RES : out std_logic_vector(15 downto 0));
end arith_09;

architecture beh of arith_09 is
    signal reg1_A, reg2_A,
           reg1_B, reg2_B : std_logic_vector(7 downto 0);
    signal reg_C, reg_mult : std_logic_vector(15 downto 0);
begin

    process (clk)
    begin
        if (clk'event and clk='1') then
            reg1_A <= A; reg2_A <= reg1_A;
            reg1_B <= B; reg2_B <= reg1_B;
            reg_C <= C;
            reg_mult <= reg2_A * reg2_B;
            RES <= reg_mult + reg_C;
        end if;
    end process;

end beh;

```

Multiplier Adder With 2 Register Levels on Multiplier Inputs, 1 Register Level after Multiplier and 1 Register Level after Adder Verilog Coding Example

```

module v_arith_09 (clk, A, B, C, RES);

    input      clk;
    input  [7:0] A;
    input  [7:0] B;
    input  [15:0] C;
    output [15:0] RES;
    reg    [7:0] reg1_A, reg2_A, reg1_B, reg2_B;
    reg    [15:0] reg_C, reg_mult, RES;

    always @(posedge clk)
    begin
        reg1_A <= A; reg2_A <= reg1_A;
        reg1_B <= B; reg2_B <= reg1_B;
        reg_C <= C;
        reg_mult <= reg2_A * reg2_B;
        RES <= reg_mult + reg_C;
    end

endmodule

```

Multiplier Up Accumulator With 2 Register Levels on Multiplier Inputs, 1 Register Level after Multiplier and 1 Register Level after Accumulator VHDL Coding Example

```

library IEEE;
use IEEE.STD_LOGIC_1164.ALL;
use IEEE.STD_LOGIC_UNSIGNED.ALL;

entity arith_10 is
    port (clk : in std_logic;
          A, B : in std_logic_vector(7 downto 0);
          RES : out std_logic_vector(15 downto 0));
end arith_10;

architecture beh of arith_10 is
    signal reg1_A, reg2_A,
           reg1_B, reg2_B : std_logic_vector(7 downto 0);
    signal reg_mult, reg_accu : std_logic_vector(15 downto 0);
begin

    process (clk)
    begin
        if (clk'event and clk='1') then
            reg1_A <= A; reg2_A <= reg1_A;
            reg1_B <= B; reg2_B <= reg1_B;
            reg_mult <= reg2_A * reg2_B;
            reg_accu <= reg_accu + reg_mult;
        end if;
    end process;

    RES <= reg_accu;

end beh;

```

Multiplier Up Accumulator With 2 Register Levels on Multiplier Inputs, 1 Register Level after Multiplier and 1 Register Level after Accumulator Verilog Coding Example

```

module v_arith_10 (clk, A, B, RES);

    input        clk;
    input  [7:0] A;
    input  [7:0] B;
    output [15:0] RES;
    reg    [7:0] reg1_A, reg2_A, reg1_B, reg2_B;
    reg    [15:0] reg_mult, reg_accu;
    wire   [15:0] RES;

    always @(posedge clk)
    begin
        reg1_A <= A; reg2_A <= reg1_A;
        reg1_B <= B; reg2_B <= reg1_B;
        reg_mult <= reg2_A * reg2_B;
        reg_accu <= reg_accu + reg_mult;
    end

    assign RES = reg_accu;

endmodule

```

Order and Group Arithmetic Functions

The ordering and grouping of arithmetic functions can influence design performance. For example, the following two VHDL statements are not necessarily equivalent:

```
ADD <= A1 + A2 + A3 + A4;  
ADD <= (A1 + A2) + (A3 + A4);
```

For Verilog, the following two statements are not necessarily equivalent:

```
ADD = A1 + A2 + A3 + A4;  
ADD = (A1 + A2) + (A3 + A4);
```

The first statement cascades three adders in series. The second statement creates two adders in parallel: **A1 + A2** and **A3 + A4**. In the second statement, the two additions are evaluated in parallel and the results are combined with a third adder. Register Transfer Level (RTL) simulation results are the same for both statements. The second statement results in a faster circuit after synthesis (depending on the bit width of the input signals).

Although the second statement generally results in a faster circuit, in some cases, you may want to use the first statement. For example, if the **A4** signal reaches the adder later than the other signals, the first statement produces a faster implementation because the cascaded structure creates fewer logic levels for **A4**. This structure allows **A4** to catch up to the other signals. In this case, **A1** is the fastest signal followed by **A2** and **A3**. **A4** is the slowest signal.

Most synthesis tools can balance or restructure the arithmetic operator tree if timing constraints require it. However, Xilinx® recommends that you code your design for your selected structure.

Resource Sharing

Resource sharing uses a single functional block (such as an adder or comparator) to implement several operators in the HDL code. Use resource sharing to improve design performance by reducing the gate count and the routing congestion. If you do not use resource sharing, each HDL operation is built with separate circuitry. You may want to disable resource sharing for speed critical paths in your design.

The following operators can be shared either with instances of the same operator or with an operator on the same line.

- *
- + -
- > >= < <=

For example, a + (plus) operator can be shared with instances of other + (plus) operators or with - (minus) operators. An * (asterisk) operator can be shared only with other * (asterisk) operators.

You can implement the following arithmetic functions with gates or with your synthesis tool module library.

- +
- -
- magnitude comparators

The library functions use modules that take advantage of the carry logic in the FPGA devices. Carry logic and its dedicated routing increase the speed of arithmetic functions that are larger than 4 bits. To increase speed, use the module library if your design contains arithmetic functions that are larger than 4 bits, or if your design contains only one arithmetic function. Resource sharing of the module library automatically occurs in most synthesis tools if the arithmetic functions are in the same process.

Resource sharing adds additional logic levels to multiplex the inputs to implement more than one function. You may not want to use it for arithmetic functions that are part of a time critical path.

Since resource sharing allows you to reduce design resources, the device area required for your design is also decreased. The area used for a shared resource depends on the type and bit width of the shared operation. You should create a shared resource to accommodate the largest bit width and to perform all operations.

If you use resource sharing in your designs, you may want to use multiplexers to transfer values from different sources to a common resource input. In designs that have shared operations with the same output target, multiplexers are reduced as shown in the following coding examples.

The VHDL example is shown implemented with gates in the following diagram.

Implementation of Resource Sharing Diagram

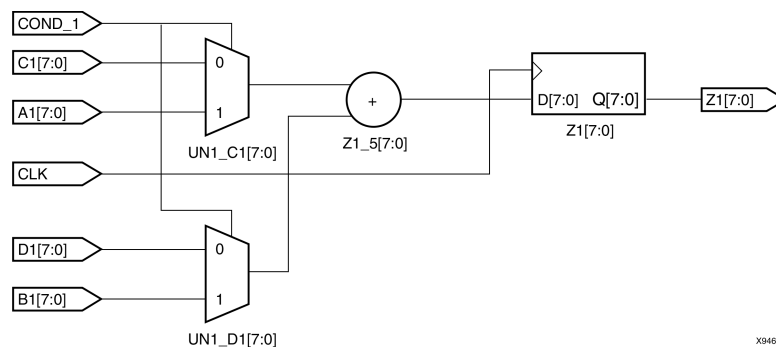

Resource Sharing VHDL Coding Example

```
-- RES_SHARING.VHD
library IEEE;
use IEEE.std_logic_1164.all;
use IEEE.std_logic_unsigned.all;
use IEEE.std_logic_arith.all;
entity res_sharing is
    port (
        A1,B1,C1,D1 : in STD_LOGIC_VECTOR (7 downto 0);
        COND_1 : in STD_LOGIC;
        Z1 : out STD_LOGIC_VECTOR (7 downto 0));
end res_sharing;
architecture BEHAV of res_sharing is
begin
    P1: process (A1,B1,C1,D1,COND_1)
    begin
        if (COND_1='1') then
            Z1 <= A1 + B1;
        else
            Z1 <= C1 + D1;
        end if;
    end process; -- end P1
end BEHAV;
```

Resource Sharing Verilog Coding Example

```

/* Resource Sharing Example
 * RES_SHARING.V
 */
module res_sharing (
input [7:0] A1, B1, C1, D1,
input COND_1,
output reg [7:0] Z1);
always @(*)
begin
    if (COND_1)
        Z1 <= A1 + B1;
    else
        Z1 <= C1 + D1;
end
endmodule

```

If you disable resource sharing, or if you code the design with the adders in separate processes, the design is implemented using two separate modules as shown in the following diagram.

Implementation Without Resource Sharing Diagram

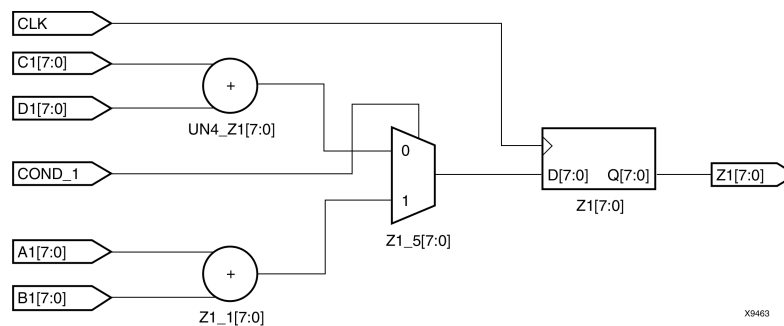

For more information, see your synthesis tool documentation.

Synthesis Tool Naming Conventions

During synthesis, the synthesis tool may preserve some net and logic names and alter others. The resulting netlist may be hard to read and hard to relate to the original code. Different synthesis tools generate names in different ways.

Knowing the naming rules that your synthesis tool uses for netlist generation helps you:

- Determine how nets and component names appearing in the final netlist relate to the original input design
- Determine how nets and names during your post-synthesis design view of the VHDL or Verilog source code relate to the original input design
- Find objects in the generated netlist and apply implementation constraints by means of the User Constraints File (UCF)

For more information, see your synthesis tool documentation.

Instantiating FPGA Primitives

Xilinx® provides a set of libraries containing architecture specific and customized components that can be explicitly instantiated as components in your design.

Architecture specific components that are built into the implementation tool's library are available for instantiation without the need to specify a definition. These components are marked as primitive in the *Libraries Guides*. Components marked as macro in the *Libraries Guides* are not built into the implementation tool's library and therefore cannot be instantiated. The macro components in the *Libraries Guides* define the schematic symbols. When macros are used, the schematic tool decomposes the macros into their primitive elements when the schematic tool writes out the netlist. FPGA primitives can be instantiated in VHDL and Verilog. All FPGA primitives are situated in the UNISIM Library.

Declaring Component and Port Map VHDL Coding Example

```
library IEEE;
use IEEE.std_logic_1164.all;
library unisim;
use unisim.vcomponents.all;
entity flops is port(
    di   : in std_logic;
    ce   : in std_logic;
    clk  : in std_logic;
    qo   : out std_logic;
    rst  : in std_logic);
end flops;

architecture inst of flops is
begin
U0 : FDCE port map(
    D   => di,
    CE  => ce,
    C   => clk,
    CLR => rst,
    Q   => qo);
end inst;
```

Declaring Component and Port Map Verilog Coding Example

```
module flops (
    input dl, ce, clk, rst,
    output ql);
    FDCE u1 (
        .D (dl),
        .CE (ce),
        .C (clk),
        .CLR (rst),
        .Q (ql));
endmodule
```

Some synthesis tools may require you to explicitly include a UNISIM library to the project.

For more information, see your synthesis tool documentation.

Many Xilinx Primitives have a set of associated properties. These constraints can be added to the primitive through:

- VHDL attribute passing
- Verilog attribute passing
- VHDL generic passing
- Verilog parameter passing
- User Constraints File (UCF)

For more information on how to use these properties, see [Attributes and Constraints](#).

Instantiating CORE Generator Software Modules

CORE Generator™ software generates:

- An Electronic Data Interchange Format (EDIF) or NGC netlist, or both, to describe the functionality
- A component instantiation template for HDL instantiation

For information on instantiating a CORE Generator software module in ISE® Design Suite, see the ISE Design Suite Help, especially, *Working with CORE Generator IP*. For more information on the CORE Generator software, see the CORE Generator software Help.

Attributes and Constraints

Some designers use *attribute* and *constraint* interchangeably, while other designers give them different meanings. Language constructs use *attribute* and *directive* in similar yet different senses. Xilinx® documentation uses *attributes* and *constraints* as defined in this section.

Attributes

An attribute is a property associated with a device architecture primitive component that affects an instantiated component's functionality or implementation. Attributes are passed as follows:

- In VHDL, by means of generic maps
- In Verilog, by means of defparams or inline parameter passing

Examples of attributes are:

- The **INIT** property on a **LUT4** component
- The **CLKFX_DIVIDE** property on a **DCM**

All attributes are described in the *Libraries Guides* as a part of the primitive component description.

Synthesis Constraints

Synthesis constraints direct the synthesis tool optimization technique for a particular design or piece of HDL code. They are either embedded within the VHDL or Verilog code, or within a separate synthesis constraints file.

Examples of synthesis constraints are:

- **USE_DSP48** (XST)
- **RAM_STYLE** (XST)

For more information, see your synthesis tool documentation.

For more information about Xilinx Synthesis Technology (XST) constraints, see the [XST User Guide for Virtex-4, Virtex-5, Spartan-3, and Newer CPLD Devices](#).

Implementation Constraints

Implementation constraints are instructions given to the FPGA implementation tools to direct the mapping, placement, timing, or other guidelines for the implementation tools to follow while processing an FPGA design. Implementation constraints are generally placed in the User Constraints File (UCF), but may exist in the HDL code, or in a synthesis constraints file.

Examples of implementation constraints are:

- LOC (placement)
- PERIOD (timing)

For more information, see the [Constraints Guide](#).

Passing Attributes

Attributes are properties that are attached to Xilinx® primitive instantiations in order to specify their behavior. They should be passed via the generic (VHDL) or parameter (Verilog) mechanism to ensure that they are properly passed to both synthesis and simulation.

VHDL Primitive Attribute Coding Example

The following VHDL coding example shows an example of setting the **INIT** primitive attribute for an instantiated **RAM16X1S** which will specify the initial contents of this **RAM** symbol to the hexadecimal value of **A1B2**.

```
small_ram_inst : RAM16X1S
generic map (
  INIT => X"A1B2")
port map (
  O => ram_out,    -- RAM output
  A0 => addr(0),   -- RAM address[0] input
  A1 => addr(1),   -- RAM address[1] input
  A2 => addr(2),   -- RAM address[2] input
  A3 => addr(3),   -- RAM address[3] input
  D => data_in,    -- RAM data input
  WCLK => clock,   -- Write clock input
  WE => we         -- Write enable input
);
```

Verilog Primitive Attribute Coding Example

The following Verilog coding example shows an instantiated **IBUFDS** symbol in which **DIFF_TERM** and **IOSTANDARD** are specified as **FALSE** and **LVDS_25** respectively.

```
IBUFDS #(
  .CAPACITANCE("DONT_CARE"), // "LOW", "NORMAL", "DONT_CARE" (Virtex-4/5 only)
  .DIFF_TERM("FALSE"),       // Differential Termination (Virtex-4/5, Spartan-3E/3A)
  .IBUF_DELAY_VALUE("0"),    // Specify the amount of added input delay for
                              // the buffer, "0"-16" (Spartan-3E/3A only)
  .IFD_DELAY_VALUE("AUTO"),  // Specify the amount of added delay for input
                              // register, "AUTO", "0"-8" (Spartan-3E/3A only)
  .IOSTANDARD("DEFAULT")     // Specify the input I/O standard
) IBUFDS_inst (
  .O(O), // Buffer output
  .I(I), // Diff_p buffer input (connect directly to top-level port)
  .IB(IB) // Diff_n buffer input (connect directly to top-level port)
);
```

Passing Synthesis Constraints

This section discusses Passing Synthesis Constraints, and includes:

- [About Passing Synthesis Constraints](#)
- [Passing VHDL Synthesis Attributes](#)
- [Passing Verilog Synthesis Attributes](#)

About Passing Synthesis Constraints

A constraint can be attached to HDL objects in your design, or specified from a separate constraints file. You can pass constraints to HDL objects in two ways:

- Predefine data that describes an object
- Directly attach an attribute to an HDL object

Predefined attributes can be passed with a COMMAND file or constraints file in your synthesis tool, or you can place attributes directly in your HDL code.

This section illustrates passing attributes in HDL code only. For information on passing attributes via the command file, see your synthesis tool documentation.

Passing VHDL Synthesis Attributes

The following are examples of VHDL attributes:

- Attribute Declaration Example
- Attribute Use on a Port or Signal Example
- Attribute Use on an Instance Example
- Attribute Use on a Component Example

Attribute Declaration Example

```
attribute attribute_name : attribute_type;
```

Attribute Use on a Port or Signal Example

```
attribute attribute_name of object_name : signal is attribute_value
```

See the following example:

```
library IEEE;
use IEEE.std_logic_1164.all;
entity d_reg is
    port (
        CLK, DATA: in STD_LOGIC;
        Q: out STD_LOGIC);
    attribute FAST : string;
    attribute FAST of Q : signal is "true";
end d_reg;
```

Attribute Use on an Instance Example

```
attribute attribute_name of object_name : label is attribute_value
```

See the following example:

```
architecture struct of sblkrams is
attribute LOC: string;
attribute LOC of SDRAM_CLK_IBUFG: label is "AA27";
Begin
  -- IBUFG: Single-ended global clock input buffer
  --   All FPGA
  -- Xilinx HDL Language Template
  SDRAM_CLK_IBUFG : IBUFG
  generic map (
    IOSTANDARD => "DEFAULT")
  port map (
    O => SDRAM_CLK_o, -- Clock buffer output
    I => SDRAM_CLK_i -- Clock buffer input
  );
  -- End of IBUFG_inst instantiation
```

Attribute Use on a Component Example

```
attribute attribute_name of object_name : component
is attribute_value
```

See the following example:

```
architecture xilinx of tenths_ex is
attribute black_box : boolean;
component tenths
  port (
    CLOCK : in STD_LOGIC;
    CLK_EN : in STD_LOGIC;
    Q_OUT : out STD_LOGIC_VECTOR(9 downto 0)
  );
end component;
attribute black_box of tenths : component is true;
begin
```

Passing Verilog Synthesis Attributes

Most vendors adopt identical syntax for passing attributes in VHDL, but not in Verilog. Historically attribute passing in Verilog was done via method called meta-comments. Each synthesis tool adopted its own syntax for meta-comments. For meta-comment syntax, see your synthesis tool documentation.

Verilog 2001 provides a uniform syntax for passing attributes. Since the attribute is declared immediately before the object is declared, the object name is not mentioned during the attribute declaration.

```
(* attribute_name = "attribute_value" *)
Verilog_object;
```

See the following example:

```
(* RLOC = "R1C0.S0" *) FDCE #(
  .INIT(1'b0) // Initial value of register (1'b0 or 1'b1)
) U2 (
  .Q(q1), // Data output
  .C(clk), // Clock input
  .CE(ce), // Clock enable input
  .CLR(rst), // Asynchronous clear input
  .D(q0) // Data input
);
```

Not all synthesis tools support this method of attribute passing.
For more information, see your synthesis tool documentation.

Pipelining

You can use pipelining to:

- Dramatically improve device performance at the cost of added latency (more clock cycles to process the data)
- Increase performance by restructuring long data paths with several levels of logic, and breaking it up over multiple clock cycles
- Achieve a faster clock cycle, and, as a result, an increased data throughput at the expense of added data latency

Because Xilinx® FPGA devices are register-rich, the pipeline is created at no cost in device resources. Since data is now on a multi-cycle path, you must account for the added path latency in the rest of your design. Use care when defining timing specifications for these paths.

Before Pipelining

In the following Before Pipelining diagram the clock speed is limited by:

- Clock-to out-time of the source flip-flop
- Logic delay through four levels of logic
- Routing associated with the four function generators
- Setup time of the destination register

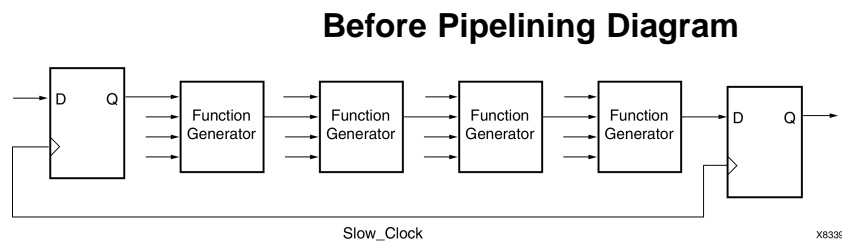

After Pipelining

The After Pipelining diagram below is an example of the same data path shown in the [Before Pipelining Diagram](#) after pipelining. Because the flip-flop is contained in the same CLB as the function generator, the clock speed is limited by:

- The clock-to-out time of the source flip-flop
- The logic delay through one level of logic: one routing delay
- The setup time of the destination register

In this example, the system clock runs much faster after pipelining than before pipelining.

After Pipelining Diagram

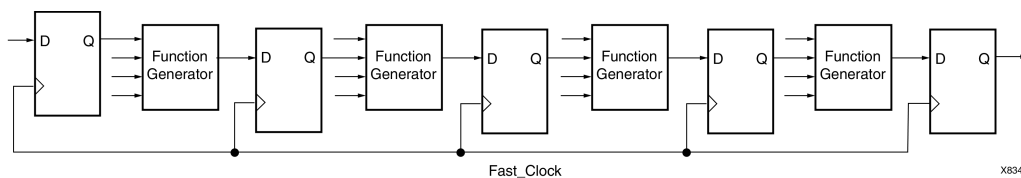

Retiming

Some synthesis tools can automatically move registers across logic (forward or backward) in order to increase design speed. This process:

- Is called Retiming or Register Balancing, depending on the synthesis tool
- Allows you to increase design speed without modifying your design
- May significantly increase the number of flip-flops

For more information, see your synthesis tool documentation.

Simulating Your Design

This chapter describes the basic Hardware Description Language (HDL) simulation flow using Xilinx® and third party tools. This chapter includes:

- [Adhering to Industry Standards](#)
- [Simulation Points in Hardware Description Language \(HDL\) Design Flow](#)
- [Using Test Benches to Provide Stimulus](#)
- [VHDL and Verilog Libraries and Models](#)
- [Simulation of Configuration Interfaces](#)
- [Disabling BlockRAM Collision Checks for Simulation](#)
- [Global Reset and Tristate for Simulation](#)
- [Design Hierarchy and Simulation](#)
- [Register Transfer Level \(RTL\) Simulation Using Xilinx Libraries](#)
- [Generating Gate-Level Netlist \(Running NetGen\)](#)
- [Disabling X Propagation for Synchronous Elements](#)
- [Using the ASYNC_REG Constraint](#)
- [MIN/TYP/MAX Simulation](#)
- [Special Considerations for CLKDLL, DCM, and DCM_ADV](#)
- [Understanding Timing Simulation](#)
- [Simulation Using Xilinx Supported EDA Simulation Tools](#)

Increasing design size and complexity, as well as improvements in design synthesis and simulation tools, have made Hardware Description Language (HDL) the preferred design languages of most integrated circuit designers. The two leading HDL synthesis and simulation languages are Verilog and VHDL. Both have been adopted as IEEE standards.

The ISE® Design Suite is designed to be used with several HDL synthesis and simulation tools that provide a solution for programmable logic designs from beginning to end. ISE Design Suite provides libraries, netlist readers, and netlist writers, along with powerful Place and Route tools, that integrate with your HDL design environment on Windows and Linux.

Adhering to Industry Standards

Xilinx® adheres to relevant industry standards:

- [Simulation Flows](#)
- [Standards Supported by Xilinx Simulation Flow](#)
- [Xilinx Supported Simulators and Operating Systems](#)
- [Xilinx Libraries](#)

Simulation Flows

Observe the rules shown in the following table when compiling source files.

Compile Order Dependency

HDL	Dependency	Compile Order
Verilog	Independent	Any order
VHDL	Dependent	Bottom-up

Xilinx® recommends that you:

- Specify the test fixture file before the HDL netlist.
- Give the name **testbench** to the main module in the test fixture file.

This name is consistent with the name used by default in the ISE® Design Suite. If this name is used, no changes are necessary to the option in ISE Design Suite in order to perform simulation from that environment.

Standards Supported by Xilinx Simulation Flow

Description	Version
VHDL	IEEE-STD-1076-2000
VITAL Modeling Standard	IEEE-STD-1076.4-2000
Verilog	IEEE-STD-1364-2001
Standard Delay Format (SDF)	OVI 3.0

Although the Xilinx Hardware Description Language (HDL) Netlister produces IEEE-STD-1076-2000 VHDL code or IEEE-STD-1364-2001 Verilog code, that does not restrict using newer or older standards for the creation of test benches or other simulation files. If the simulator supports both older and newer standards, both standards can generally be used in these simulation files. You must indicate to the simulator during code compilation which standard was used to create the file.

Xilinx® does not support SystemVerilog. For more information, contact the Xilinx EDA partners listed in the following sections for their SystemVerilog roadmaps:

- [Simulating Xilinx Designs in ModelSim](#)
- [Simulating Xilinx Designs in IES](#)
- [Simulating Xilinx Designs in Synopsys VCS and VCS MX](#)

Xilinx Supported Simulators and Operating Systems

Simulator	RH Linux	RH Linux-64	SuSe Linux	SuSe Linux-64	Windows XP	Windows XP-64	Windows Vista	Windows Vista-64
ISim	√	√	√	√	√	N/A	√	N/A
ModelSim SE, (6.6d)	√	√	√	√	√	√	√	√
ModelSim PE, (6.6d)	N/A	N/A	N/A	√	√	√	√	√
ModelSim DE, (6.6d)	√	√	√	√	√	√	√	√

Simulator	RH Linux	RH Linux-64	SuSe Linux	SuSe Linux-64	Windows XP	Windows XP-64	Windows Vista	Windows Vista-64
Mentor Questa (6.6d)	√	√	√	√	√	√	√	√
Cadence Incisive Enterprise Simulator (IES) (10.2)	√	√	√	√	N/A	N/A	N/A	N/A
Synopsys VCS and VCS MX (2010.06)	√	√	√	√	N/A	N/A	N/A	N/A
Aldec Active-HDL (8.3)	N/A	N/A	N/A	N/A	√	√	√	√
Aldec Riviera-PRO (2010.10)	√	√	√	√	√	√	√	√

Xilinx® does not support the UNIX operating system.

Xilinx recommends that you run the most current version of the simulator.

Since Xilinx develops its libraries and simulation netlists using IEEE standards, you should be able to use most current VHDL and Verilog simulators. Check with your simulator vendor to confirm that the standards are supported by your simulator, and to verify the settings for your simulator.

Xilinx Libraries

The Xilinx® VHDL libraries are tied to the IEEE-STD-1076.4-2000 VITAL standard for simulation acceleration. VITAL 2000 is in turn based on the IEEE-STD-1076-93 VHDL language. Because of this, the Xilinx libraries must be compiled as 1076-93.

VITAL libraries include some additional processing for timing checks and back-annotation styles. The UNISIM library turns these timing checks off for unit delay functional simulation. The SIMPRIM back-annotation library keeps these checks on by default to allow accurate timing simulations.

Simulation Points in Hardware Description Language (HDL) Design Flow

Xilinx® supports functional and timing simulation of Hardware Description Language (HDL) designs as shown in the Five Simulation Points in HDL Design Flow section below.

The following diagram shows the points of the design flow.

Primary Simulation Points for Hardware Description Language (HDL) Designs Diagram

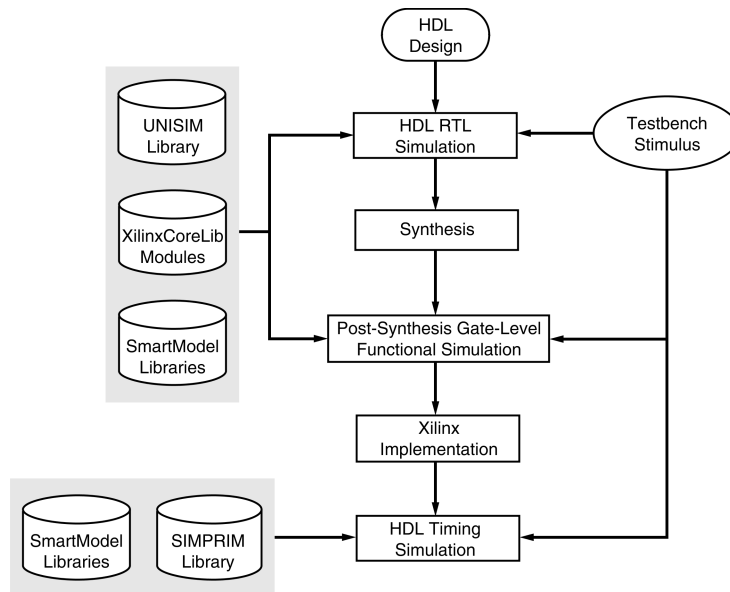

X10018

The Post-NGDBuild and Post-Map simulations can be used when debugging synthesis or map optimization issues.

Five Simulation Points in Hardware Description Language (HDL) Design Flow

	UNISIM	UniMacro	XilinxCoreLib Models	SecureIP	SIMPRIM	Standard Delay Format (SDF)
1. Register Transfer Level (RTL)	√	√	√	√	N/A	N/A
2. Post-Synthesis (Pre-NGDBuild) Gate-Level Simulation (optional)	√	N/A	N/A	√	N/A	N/A
3. Post-NGDBuild (Pre-Map) Gate-Level Simulation (optional)	N/A	N/A	N/A	√	√	N/A
4. Post-Map Partial Timing (Block Delays) (optional)	N/A	N/A	N/A	√	√	√
5. Timing Simulation Post-Place and Route (Block and Net Delays)	N/A	N/A	N/A	√	√	√

For more information about SecureIP, see [Encryption Methodology Used for SecureIP Models](#).

Simulation Flow Libraries

The libraries required to support the simulation flows are described in detail in [VHDL and Verilog Libraries and Models](#). The flows and libraries support functional equivalence of initialization behavior between functional and timing simulations.

Different simulation libraries support simulation before and after running NGDDBuild:

- Before running NGDDBuild, your design is expressed as a UNISIM netlist containing Unified Library components that represent the logical view of the design.
- After running NGDDBuild, your design is a netlist containing the SIMPRIM models that represent the physical view of the design.

Although these library changes are fairly transparent, remember that:

- You must specify different simulation libraries for pre- and post-implementation simulation.
- There are different gate-level cells in pre- and post-implementation netlists.

VHDL Standard Delay Format (SDF) File

For VHDL, you must specify:

- The location of the Standard Delay Format (SDF) file
- Which instance to annotate during the timing simulation

The method for doing this depends on the simulator being used. Typically, a command line or program switch is used to read the Standard Delay Format (SDF). For more information on annotating SDF files, see your simulation tool documentation.

Verilog Standard Delay Format (SDF) File

For Verilog, within the simulation netlist the Verilog system task `$sdf_annotate` specifies the name of the Standard Delay Format (SDF) file to be read.

- If the simulator supports `$sdf_annotate`, the SDF file is automatically read when the simulator compiles the Verilog simulation netlist.
- If the simulator does not support `$sdf_annotate`, in order to apply timing values to the gate-level netlist, you must manually instruct the simulator to annotate the SDF file.

Register Transfer Level (RTL)

Register Transfer Level (RTL) may include:

- RTL Code
- Instantiated UNISIM library components
- Instantiated UniMacro components
- XilinxCoreLib and UNISIM gate-level models (CORE Generator™ software)
- SecureIP

The RTL-level (behavioral) simulation enables you to verify or simulate a description at the system or chip level. This first pass simulation is typically performed to verify code syntax, and to confirm that the code is functioning as intended. At this step, no timing information is provided, and simulation should be performed in unit-delay mode to avoid the possibility of a race condition.

RTL simulation is not architecture-specific unless the design contains instantiated UNISIM or CORE Generator software components. To support these instantiations, Xilinx® provides the UNISIM and XilinxCoreLib libraries. You can use CORE Generator software components if:

- You do not want to rely on the module generation capabilities of the synthesis tool, or
- The design requires larger structures.

Keep the code behavioral for the initial design creation. Do not instantiate specific components unless necessary. This allows for:

- More readable code
- Faster and simpler simulation
- Code portability (the ability to migrate to different device families)
- Code reuse (the ability to use the same code in future designs)

You may find it necessary to instantiate components if the component is not inferable.

Post-Synthesis (Pre-NGDBuild) Gate-Level Simulation

Post-Synthesis (Pre-NGDBuild) Gate-Level Simulation may include one of the following (optional):

- Gate-level netlist containing UNISIM library components
- SecureIP

Most synthesis tools can write out a post-synthesis HDL netlist for a design. If the VHDL or Verilog netlists are written for UNISIM library components, you may use the netlists to simulate the design and evaluate the synthesis results.

Xilinx® does not support this method if the netlists are written in terms of the vendor's own simulation models.

Post-NGDBuild (Pre-Map) Gate-Level Simulation

Post-NGDBuild (Pre-Map) Gate-Level Simulation (optional) may include:

- Gate-level netlist containing SIMPRIM library components
- SecureIP

The post-NGDBuild (pre-map) gate-level functional simulation is used when it is not possible to simulate the direct output of the synthesis tool. This occurs when the tool cannot write UNISIM compatible VHDL or Verilog netlists. In this case, the NGD file produced from NGDBuild is the input into the Xilinx® simulation Netlister, NetGen. NetGen creates a structural simulation netlist based on SIMPRIM models.

Like post-synthesis simulation, post-NGDBuild simulation allows you to verify that your design has been synthesized correctly, and you can begin to identify any differences due to the lower level of abstraction. Unlike the post-synthesis pre-NGDBuild simulation, there are Global Set/Reset (GSR) and Global Tristate (GTS) nets that must be initialized, just as for post-Map and post-PAR simulation. For more information on using the **GSR** and **GTS** signals for post-NGDBuild simulation, see [Global Reset and Tristate for Simulation](#).

Post-Map Partial Timing (Block Delays)

Post-Map Partial Timing (Block Delays) may include the following (optional):

- Gate-level netlist containing SIMPRIM library components
- Standard Delay Format (SDF) files
- SecureIP

You may also perform simulation after mapping the design. Post-Map simulation occurs before placing and routing. This simulation includes the block delays for the design, but not the routing delays. Since routing is not taking into consideration, the simulation results may be inaccurate. Run this simulation as a debug step only if post-place and route simulation shows failures.

As with the post-NGDBuild simulation, NetGen is used to create the structural simulation. Running the simulation Netlister tool, NetGen creates a Standard Delay Format (SDF) file. The delays for the design are stored in the SDF file which contains all block or logic delays. It does not contain any of the routing delays for the design since the design has not yet been placed and routed. As with all netlists created with NetGen, Global Set/Reset (GSR) and Global Tristate (GTS) signals must be accounted for. For more information on using the GSR and GTS signals for post-NGDBuild simulation, see [Global Reset and Tristate for Simulation](#).

Timing Simulation Post-Place and Route (Block and Net Delays)

Timing Simulation Post-Place and Route Full Timing (Block and Net Delays) may include:

- Gate-level netlist containing SIMPRIM library components
- Standard Delay Format (SDF) files
- SecureIP

After your design has completed the Place and Route process in ISE® Design Suite, a timing simulation netlist can be created. You now begin to see how your design behaves in the actual circuit. The overall functionality of the design was defined in the beginning, but timing information can not be accurately calculated until the design has been placed and routed.

The previous simulations that used NetGen created a structural netlist based on SIMPRIM models. This netlist comes from the placed and routed Native Circuit Description (NCD) file. This netlist has Global Set/Reset (GSR) and Global Tristate (GTS) nets that must be initialized. For more information on initializing the GSR and GTS nets, see [Global Reset and Tristate for Simulation](#).

When you run timing simulation, a Standard Delay Format (SDF) file is created as with the post-Map simulation. This SDF file contains all block and routing delays for the design.

Xilinx® highly recommends running this flow. For more information, see [Importance of Timing Simulation](#).

Using Test Benches to Provide Stimulus

Before you perform simulation, create a test bench or test fixture to apply the stimulus to the design.

A test bench is Hardware Description Language (HDL) code written for the simulator that:

- Instantiates the design netlists
- Initializes the design
- Applies stimuli to verify the functionality of the design

You can also set up the test bench to display the desired simulation output to a file, waveform, or screen.

A test bench can be simple in structure and sequentially apply stimulus to specific inputs. A test bench can also be complex, and may include:

- Subroutine calls
- Stimulus read in from external files
- Conditional stimulus
- Other more complex structures

The test bench has the following advantages over interactive simulation:

- It allows repeatable simulation throughout the design process.
- It provides documentation of the test conditions.

For more information, see [Xilinx Application Note XAPP199, Writing Efficient Test Benches](#).

Creating a Test Bench

Use either of the following to create a test bench and simulate a design:

- ISE® Design Suite

ISE Design Suite creates a template test bench containing the proper structure, library references, and design instantiation based on your design files. This greatly eases test bench development at the beginning stages of the design.

- NetGen

Use the `-tb` switch in NetGen to create a test bench file.

Test Bench Files Created by NetGen

Language	File Name	File Extension
VHDL	test bench	.tvhd
Verilog	test fixture	.tv

Test Bench Recommendations

When you create and run a test bench, Xilinx® recommends that you:

- Give the name `testbench` to the main module or entity name in the test bench file. Always specify the ``timescale` in Verilog testbench files.
- Specify the instance name for the instantiated top-level of the design in the test bench as UUT.

These names are consistent with the default names used by ISE® Design Suite for calling the test bench and annotating the Standard Delay Format (SDF) file when invoking the simulator.

- Initialize all inputs to the design within the test bench at simulation time zero in order to properly begin simulation with known values.
- Apply stimulus data *after* 100 ns in order to account for the default Global Set/Reset (GSR) pulse used in SIMPRIM-based simulation. The clock source should begin before the Global Set/Reset (GSR) is released. For more information, see [Global Reset and Tristate for Simulation](#).

VHDL and Verilog Libraries and Models

VHDL and Verilog libraries and models include:

- [Required Simulation Point Libraries](#)
- [Simulation Phase Library Information](#)
- [Library Source Files and Compile Order](#)

Required Simulation Point Libraries

The five simulation points require the following libraries:

- UNISIM
- UniMacro
- CORE Generator™ software (XilinxCoreLib)
- SecureIP
- SIMPRIM

First Simulation Point: Register Transfer Level (RTL)

The first point, Register Transfer Level (RTL), is a behavioral description of your design at the register transfer level. RTL simulation is not architecture-specific unless your design contains instantiated UNISIM, or CORE Generator software components.

To support these instantiations, Xilinx® provides the following libraries:

- UNISIM
- UniMacro
- CORE Generator technology behavioral XilinxCoreLib
- SecureIP

Second Simulation Point: Post-Synthesis (Pre-NGDBuild) Gate-Level Simulation

The second simulation point is Post-Synthesis (Pre-NGDBuild) Gate-Level Simulation.

The synthesis tool must write out the HDL netlist using UNISIM primitives. Otherwise, the synthesis vendor provides its own post-synthesis simulation library, which is not supported by Xilinx. If there is IP in the design that is a blackbox for the synthesis tools, NGCBuild must run before **netgen**. NGCBuild combines all the `ngc` and Electronic Data Interchange Format (EDIF) files into a single `ngc`. NetGen can be then run on this `ngc` file. For more information on running NGCBuild, see the NGCBuild chapter in the [Command Line Tools User Guide](#).

Xilinx provides the following libraries:

- UNISIM
- UniMacro
- SecureIP

Third Simulation Point: Post-NGDBuild (Pre-Map) Gate-Level Simulation

The third simulation point is Post-NGDBuild (Pre-Map) Gate-Level Simulation. This simulation point requires the SIMPRIM and SecureIP Libraries.

Fourth Simulation Point: Post-Map Partial Timing (Block Delays)

The fourth simulation point is Post-Map Partial Timing (Block Delays). This simulation point requires the SIMPRIM and SecureIP Libraries.

Fifth Simulation Point: Timing Simulation Post-Place and Route (Block and Net Delays)

The fifth simulation point is Timing Simulation Post-Place and Route (Block and Net Delays). This simulation point requires the SIMPRIM and SecureIP Libraries.

Simulation Phase Library Information

Library Required for Each of the Five Simulation Points

Simulation Point	Compilation Order of Library Required
First Simulation Point Register Transfer Level (RTL)	UNISIM UniMacro XilinxCoreLib SecureIP
Second Simulation Point Post-Synthesis (Pre-NGDBuild) Gate-Level Simulation	UNISIM UniMacro SecureIP
Third Simulation Point Post-NGDBuild (Pre-Map) Gate-Level Simulation	SIMPRIM
Fourth Simulation Point Post-Map Partial Timing (Block Delays)	SIMPRIM SecureIP
Fifth Simulation Point Timing Simulation Post-Place and Route (Block and Net Delays)	SIMPRIM SecureIP

Library Source Files and Compile Order

Xilinx® recommends using Compxlib for compiling libraries.

Compilation order is required for *all* VITAL VHDL source files.

Simulation Library VITAL VHDL Location of Source Files (Linux)

Libraries	Location of Source Files (Linux)
UNISIM	\$XILINX/vhdl/src/unisims \$XILINX/vhdl/src/unimacro
UNISIM 9500	\$XILINX/vhdl/src/unisims
XilinxCoreLib FPGA Families only	\$XILINX/vhdl/src/XilinxCoreLib
SecureIP	\$XILINX/secureip/<simulator> /
SIMPRIM (All Xilinx Technologies)	\$XILINX/vhdl/src/simprims

Simulation Library VITAL VHDL Location of Source Files (Windows)

Libraries	Location of Source Files (Windows)
UNISIM	%XILINX%\vhdl\src\unisims %%XILINX%\vhdl\src\unimacro
UNISIM 9500	%XILINX%\vhdl\src\unisims
XilinxCoreLib FPGA Families only	%XILINX%\vhdl\src\XilinxCoreLib
SecureIP	%XILINX%\secureip\ <i><simulator></i> \
SIMPRIM (All Xilinx Technologies)	%XILINX%\vhdl\src\simprims

Simulation Library VITAL VHDL Required Compile Order

Libraries	Compile Order
UNISIM	<ul style="list-style-type: none"> • unisim_VCOMP.vhd • unisim_VPKG.vhd • primitive/vhdl_analyze_order • unimacro_VCOMP.vhd • all files in the UniMacro directory
UNISIM 9500	<ul style="list-style-type: none"> • unisim_VCOMP.vhd • unisim_VPKG.vhd • primitive/vhdl_analyze_order
SecureIP	<p>Functional Simulation</p> <ul style="list-style-type: none"> • UNISIM Libraries • <i><simulator></i>_secureip_cell.list.f • \$XILINX/vhdl/src/unisims/secureip/other/vhdl_analyze_order <p>Timing Simulation</p> <ul style="list-style-type: none"> • SIMPRIM Libraries • <i><simulator></i>_secureip_cell.list.f • \$XILINX/vhdl/src/simprims/secureip/other/vhdl_analyze_order or \$XILINX/vhdl/src/simprims/secureip/modelsim/vhdl_analyze_order (ModelSim only)
SIMPRIM (All Xilinx Technologies)	<ul style="list-style-type: none"> • simprim_Vcomponents.vhd OR simprim_Vcomponents_ModelSim.vhd (ModelSim only) • simprim_Vcomponents.vhd OR simprim_Vpackage_mti.vhd (ModelSim only) • primitive/other/vhdl_analyze_order • primitive/modelsim/vhdl_analyze_order

Simulation Library Verilog Source Files (Linux)

Libraries	Location of Source Files (Linux)
UNISIM	\$XILINX/verilog/src/unisims \$XILINX/verilog/src/unimacro
UNISIM 9500	\$XILINX/verilog/src/uni9000
XilinxCoreLib FPGA Families only	UNISIM Libraries \$XILINX/verilog /src/XilinxCoreLib
SecureIP	UNISIM Libraries <simulator>_secureip_cell.list.f
SIMPRIM (All Xilinx Technologies)	\$XILINX/verilog/src/simprims

Simulation Library Verilog Source Files (Windows)

Libraries	Location of Source Files (Windows)
UNISIM	%XILINX%\verilog\src\unisims %XILINX%\verilog\src\unimacro
UNISIM 9500	%XILINX%\verilog\src\uni9000
XilinxCoreLib FPGA Families only	UNISIM Libraries %XILINX%\verilog\src\XilinxCoreLib
SecureIP	UNISIM Libraries <simulator>_secureip_cell.list.f
SIMPRIM (All Xilinx Technologies)	%XILINX%\verilog\src\simprims

No special compilation order is required for Verilog libraries

Simulation Libraries

XST supports the following simulation libraries:

- UNISIM Library
- VHDL UNISIM Library
- Verilog UNISIM Library
- UniMacro Library
- VHDL UniMacro Library
- Verilog UniMacro Library
- CORE Generator™ Software XilinxCoreLib Library
- SIMPRIM Library
- SecureIP Libraries
- VHDL SecureIP Library
- Verilog SecureIP Library
- Xilinx® Simulation Libraries (Compplib)

UNISIM Library

The UNISIM Library is used for functional simulation and synthesis only. This library includes:

- All Xilinx Unified Library primitives that are inferred by most synthesis tools
- Primitives that are commonly instantiated, such as:
 - **DCM**
 - **BUFG**
 - **MGT**

Xilinx recommends that you infer most design functionality using behavioral Register Transfer Level (RTL) code unless:

- The desired component is not inferable by your synthesis tool, or
- You want to take manual control of mapping and placement of a function

VHDL UNISIM Library

The VHDL UNISIM library is split into four files containing:

- The component declarations (`unisim_VCOMP.vhd`)
- Package files (`unisim_VPKG.vhd`)
- Entity and architecture declarations (`unisim_VITAL.vhd`)

All primitives for all Xilinx device families are specified in these files. To use these primitives, place the following two lines at the beginning of each file:

```
Library UNISIM;  
use UNISIM.vcomponents.all;
```

Verilog UNISIM Library

For Verilog, each library component is specified in a separate file. This allows automatic library expansion using the `-y` library specification switch. All Verilog module names and file names are all upper case. For example, module **BUFG** is `BUFG.v`, and module **IBUF** is `IBUF.v`. Since Verilog is case-sensitive, make sure that all UNISIM primitive instantiations adhere to this upper-case naming convention.

If you are using pre-compiled libraries, use the correct directive to point to the precompiled libraries. Following is an example for ModelSim:

```
-L unisims_ver
```

UniMacro Library

The UniMacro library:

- Is used for functional simulation and synthesis only.
- Provides macros to aid the instantiation of complex Xilinx primitives.
- Is an abstraction of the primitives in the UNISIM library. The synthesis tools automatically expand each UniMacro to its underlying primitive.

For more information, see the [Libraries Guides](#).

VHDL UniMacro Library

To use these macros, place the following two lines at the beginning of each file, *in addition* to the UNISIM declarations:

```
Library UNIMACRO;  
use UNIMACRO.vcomponents.all
```

Verilog UniMacro Library

For Verilog, each macro component is specified in a separate file. This allows automatic library expansion using the `-y` library specification switch. All Verilog module names and file names are all UPPER CASE. Since Verilog is case-sensitive, make sure that all UniMacro instantiations adhere to this UPPER CASE naming convention.

If you are using pre-compiled libraries, use the correct directive to point to the precompiled libraries. Following is an example for ModelSim:

```
-L unimacro_ver
```

CORE Generator Software XilinxCoreLib Library

The CORE Generator software is a graphical intellectual property (IP) design tool for creating high-level modules such as:

- FIR Filters
- FIFOs
- CAMs
- Other advanced IP

You can customize and pre-optimize modules to take advantage of the inherent architectural features of Xilinx FPGA devices, such as:

- Block multiplier
- SRL
- Fast carry logic
- On-chip single-port RAM
- On-chip dual-port RAM

You can also select the appropriate HDL model type as output to integrate into your HDL design.

The CORE Generator software HDL library models are used for Register Transfer Level (RTL) simulation.

SIMPRIM Library

The SIMPRIM library is used for the following simulations:

- Post NGDBuild (gate level functional)
- Post-Map (partial timing)
- Post-Place and Route (full timing)

The SIMPRIM library is architecture independent.

SecureIP Libraries

IP Blocks are fully supported in ISim without additional setup. For more information see the [ISim User Guide](#). Xilinx leverages the latest encryption methodology as specified in Verilog LRM - IEEE Std 1364–2005. Virtex®-4 and Virtex-5 device simulation models for the IP such as PowerPC processors, MGT, and PCIe® leverages this technology. Everything is automatically handled by means of Compplib, provided the appropriate version of the simulator is present on your computer. When running a simulation with this new methodology in Verilog, you must reference the SecureIP library. For most simulators, this can be done by using the `-L` switch as an argument to the simulator, such as `-L secureip`. For the switch to use with your simulator, see your simulator documentation.

Note Use the `-Ica` switch when using SecureIP.

The table below lists special considerations that need to be arranged with your simulator vendor for using these libraries.

Special Considerations for Using SecureIP Libraries

Simulator Name	Vendor	Special Requirements
ModelSim SE ModelSim PE ModelSim DE Questa	Mentor Graphics	If design entry is in VHDL, a mixed language license or a SecureIP OP is required. Please contact the vendor for more information.
IUS	Cadence	An export control regulation license is required.
VCS	Synopsys	The usage of <code>-lca</code> switch with the VCS commands are required when simulating designs with SecureIP in them

VHDL SecureIP Library

If you are using VHDL for your design entry, a mixed-language license (or the SecureIP Op for Mentor products) is required to run any IP simulation. Contact your vendor for pricing options for mixed-language simulation.

To use SecureIP, place the following two lines at the beginning of each file:

```
Library UNISIM;
use UNISIM.vcomponents.all;
```

Verilog SecureIP Library

These libraries can be used at compile time by leveraging the `-f` switch in the simulator. Following is an example for VCS:

```
vcs -lca -f $XILINX/secureip/vcs/vcs_secureip_cell.list.f \
-y $XILINX/verilog/src/unisims -y $XILINX/verilog/src/xilinxcorelib \
+incdir+$XILINX/verilog/src +libext+.v $XILINX/verilog/src/glbl.v \
-Mupdate -R <testfixture> .v <design> .y
```

If you are using pre-compiled libraries, use the correct directive to point to the precompiled libraries. Following is an example for ModelSim:

```
-L secureip
```

Xilinx Simulation Libraries (Compplib)

Do NOT use with ISim.

Before beginning functional simulation, you must use Compplib to compile the Xilinx Simulation Libraries for the target simulator. For more information, see the [Command Line Tools User Guide](#).

Reducing Simulation Runtimes

Xilinx® simulation models have an optional generic/parameter (`SIM_MODE`) that can reduce the simulation runtimes. `SIM_MODE` has two settings:

- `SIM_MODE = "SAFE"`
- `SIM_MODE = "FAST"`

The different settings impact simulation support of certain features of the primitive. This setting is supported on the following UNISIM primitives:

- Virtex®-5 device BlockRAM
- Virtex-5 device FIFO
- Virtex-5 device DSP Block

The following tables list the features that are *not* supported when using **FAST** mode.

Virtex-5 Device BlockRAM Features Not Supported When Using FAST Mode

Feature	Description
Parameter validity checks	Checks for the generics/parameters to ensure that they are legal for the primitive in use
Cascade feature	Ability to cascade multiple BlockRAMs together
ECC feature	Error checking and correction
Memory collision checks	Checks to ensure that data is not being written to and read from the same address location

Virtex-5 Device FIFO Features Not Supported When Using FAST Mode

Feature	Description
Parameter checks	Checks for the generics/parameters to ensure that they are legal for the primitive in use
Design rule checks for reset	When doing a reset, the model will not check for correct number of reset pulses being applied
ECC feature	Error checking and correction

Virtex-5 Device DSP Block Features Not Supported When Using FAST Mode

Feature	Description
DRC checks – opmode and alumode	The DSP48 block has various design rule checks for the opmode and alumode settings that have been removed

For a complete simulation, and to insure that the simulation model functions in hardware as expected, use **SAFE** mode.

SIM_MODE applies to UNISIM Register Transfer Level (RTL) simulation models only. **SIM_MODE** is not supported for SIMPRIM gate simulation models. For a SIMPRIM based simulation, the model performs every check at the cost of simulation runtimes.

Simulation of Configuration Interfaces

This section discusses Simulation of Configuration Interfaces, and includes:

- [JTAG Simulation](#)
- [SelectMAP Simulation](#)
- [Spartan®-3AN In-System Flash Simulation](#)

JTAG Simulation

Simulation of the **BSCAN** component is supported for the following devices:

- Virtex®-4
- Virtex-5
- Virtex-6
- Spartan®-3A
- Spartan®-6

The simulation supports the interaction of the **JTAG** ports and some of the **JTAG** operation commands. The **JTAG** interface, including interface to the scan chain, is not yet fully supported. In order to simulate this interface:

1. Instantiate the **BSCAN_VIRTEX4**, **BSCAN_VIRTEX5**, **BSCAN_VIRTEX6**, **BSCAN_SPARTAN3A**, or **BSCAN_SPARTAN6** component and connect it to the design.
2. Instantiate the **JTAG_SIM_VIRTEX4**, **JTAG_SIM_VIRTEX5**, **JTAG_SIM_VIRTEX6**, **JTAG_SIM_SPARTAN3A**, or **JTAG_SIM_SPARTAN6** component into the test bench (not the design).

This becomes:

- The interface to the external **JTAG** signals (such as **TDI**, **TDO**, and **TCK**)
- The communication channel to the **BSCAN** component

The communication between the components takes place in the VPKG VHDL package file or the **glbl** Verilog global module. Accordingly, no implicit connections are necessary between the specific **JTAG_SIM_(Device)** component and the design, or the specific **BSCAN_(Device)** symbol.

Stimulus can be driven and viewed from the specific **JTAG_SIM_(Device)** component within the test bench to understand the operation of the **JTAG/BSCAN** function. Instantiation templates for both of these components are available in both the ISE® Design Suite HDL Templates and the specific device *Libraries Guides*.

SelectMAP Simulation

The configuration simulation model (**SIM_CONFIG_xx**) with an instantiation template allows supported configuration interfaces to be simulated ultimately showing the **DONE** pin going **high**. This is a model of how the supported devices will react to stimulus on the supported configuration interface. For a list of supported interfaces and devices, see the following table. The model is set up to handle control signal activity as well as bit file downloading. Included are internal register settings such as the CRC, IDCODE, and Status Registers. The Sync Word can be monitored as it enters the device and the Start Up Sequence can be monitored as it progresses. The diagram below shows how the system should map from the hardware to the simulation environment. The configuration process is specifically outlined in the *Configuration User Guides* for each device family. These guides contain information on the configuration sequence as well as the configuration interfaces.

Supported Configuration Devices and Modes

Devices	SelectMAP	Serial	SPI	BPI
Virtex®-6	Yes	Yes	No	No
Virtex®-5	Yes	No	No	No
Spartan®-6	Yes	Yes	No	No
Spartan®-3A	Yes	No	No	No

Block Diagram of Model Interaction

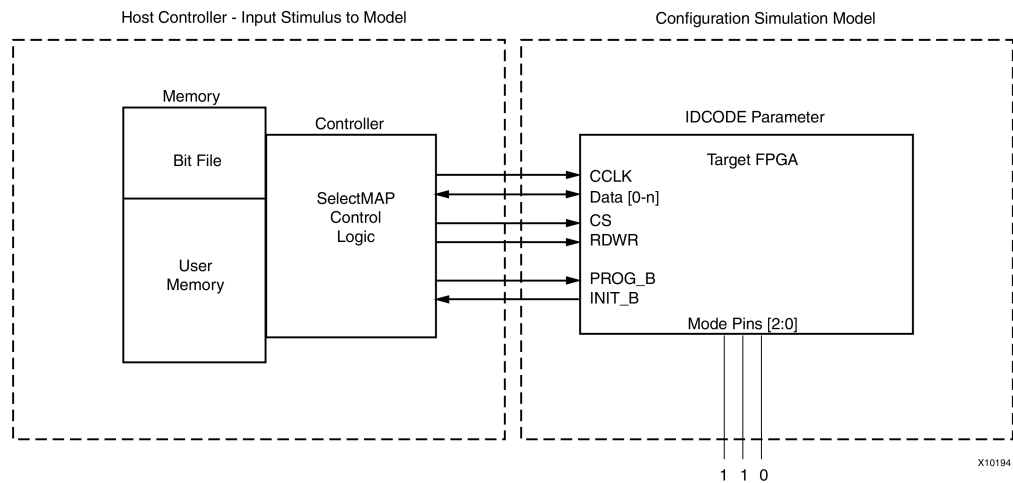

System Level Description

This model simulates the entire device and is to be used at a system level. Applications using a processor to control the configuration logic can leverage this model to ensure proper wiring, control signal handling, and data input alignment. Applications that control the data loading process with the **CS** (SelectMAP Chip Select) or **CLK** signal can be tested to ensure proper data alignment. Systems that need to perform a SelectMAP **ABORT** or **Readback** can also leverage this model.

There is a zip file associated with this model at ftp://ftp.xilinx.com/pub/documentation/misc/config_test_bench.zip. This zip file has sample test benches simulating a processor running the SelectMAP logic. These test benches have control logic to emulate a processor controlling the SelectMAP interface. Features such as a full configuration, **ABORT**, and **Readback** of the IDCODE and Status Registers are included. The host system being simulated must have a method for file delivery as well as control signal management. These control systems should be designed as set forth in the [Configuration User Guides](#). This model allows the configuration interface control logic to be tested before the hardware is available.

The model also demonstrates what is occurring inside of the device during the configuration procedure when a bitfile is loaded into the device. During the bitfile download, the model is processing each command and changing registers setting that mirror the hardware changes. The CRC register can be monitored as it actively accumulates a CRC value. The model also shows the Status Register bits being set as the device progresses through the different states of configuration.

Debugging with the Model

This model provides an example of a correct configuration. This example can be leveraged to assist in the debug procedure if problems are encountered. The Status Register contains information regarding the current status of the device and is very useful in debugging. This register can be read out of the device via JTAG using iMPACT. If problems are encountered on the board, the Status Register read from impact should be one of the first debugging steps taken.

Once the status register has been read, it can be mapped to the simulation. This will point out what stage of configuration the device is in. For example, the **GHIGH** bit is set after the data load if this bit has not been set the data loading did not complete. The **GTW**, **GWE**, and **DONE** signals all set in BitGen that are released in the start up sequence can be monitored.

The model also allows for error injection. The active CRC logic detects any problems if the data load is paused and started again with any problems. Bit flips manually inserted in the bitfile are also detected and handled just as the device would handle this error.

Supported Features

Each device-specific [Configuration User Guides](#) outlines the supported methods of interacting with each configuration interface. This guide outlines items discussed in the [Configuration User Guides](#), which are not supported by the model, Spartan-3A Slave SelectMAP Features Supported by the Model, and Virtex-5 Slave SelectMAP Features Supported by the Model, list features discussed in the [Configuration User Guides](#) not supported by the model.

Readback of configuration data is not supported by the model. The model does not store configuration data provided although a CRC value is calculated. Readback can only be performed on specific registers to ensure a valid command sequence and signal handling is provided to the device. The model is not intended to allow readback data files to be produced.

Slave SelectMAP and Serial Features Supported by the Model for all Device Families

Features (Configuration User Guides and Software Manual Sections)	Supported
Master mode	No
Daisy Chaining Spartan-3E device and Spartan-3A device Slave Parallel Daisy Chains	Yes
Daisy Chaining Slave Parallel Daisy Chains Using Any Modern Xilinx® FPGA Family	No
SelectMAP Data Loading	Yes
Continuous SelectMAP Data Loading	Yes
Non-Continuous SelectMAP Data Loading	Yes
SelectMAP ABORT	Yes
SelectMAP Reconfiguration	No
SelectMAP Data Ordering	Yes
Reconfiguration and MultiBoot	No
Configuration CRC – CRC Checking during Configuration	Yes
Configuration CRC – Post-Configuration CRC	No
BitGen modifications to DONE_cycle , GTS_cycle , GWE_cycle	Yes
BitGen modifications other options from the default value	Altering DONE , GTS , and GWE release positions affects only their timing
Wait for DCM simulation capabilities	Yes (Spartan®-6 only)

Virtex-5 Device Slave SelectMAP Features Supported by the Model

Features (Configuration User Guides / Software Manual Sections)	Supported
Master mode	No
Single Device SelectMAP Configuration	Yes
Multiple Device SelectMAP Configuration	Yes
Parallel Daisy Chain	Yes
Ganged SelectMAP	Yes
SelectMAP Data Loading	Yes
SelectMAP ABORT	Yes
SelectMAP Reconfiguration	No
SelectMAP Data Ordering	Yes
Readback and Configuration Verification	Only the IDCODE and Status Registers can be readback
Reconfiguration and MultiBoot	No
Readback CRC	No
BitGen modifications to DONE_cycle , GTS_cycle , GWE_cycle	Altering DONE , GTS , and GWE release positions affects only their timing
BitGen modifications other options from the default value	No

Spartan-3AN In-System Flash Simulation

Spartan-3AN devices have an internal memory feature that can be used for initial configuration, multiboot, user memory, or a combination of these. To access the memory once the device is configured, the application loaded into the FPGA device must use a special design primitive called **SPI_ACCESS**. All data accesses to and from the ISF (In System Flash) memory are performed using an **SPI** (Serial Peripheral Interface) protocol. Neither the Spartan-3AN device itself, nor the **SPI_ACCESS** primitive, includes a dedicated **SPI** master controller. Instead, the control logic is implemented using the programmable logic resources of the FPGA device. The **SPI_ACCESS** primitive essentially connects the FPGA device application to the In-System Flash memory array. The simulation model allows you to test the behavior of this interface in simulation. This interface consists of the four standard SPI connections:

- **MOSI** (Master Out Slave In)
- **MISO** (Master In Slave Out)
- **CLK** (Clock)
- **CSB** (Active-Low Chip Select)

Spartan-3AN SPI_ACCESS Connections to ISF Memory

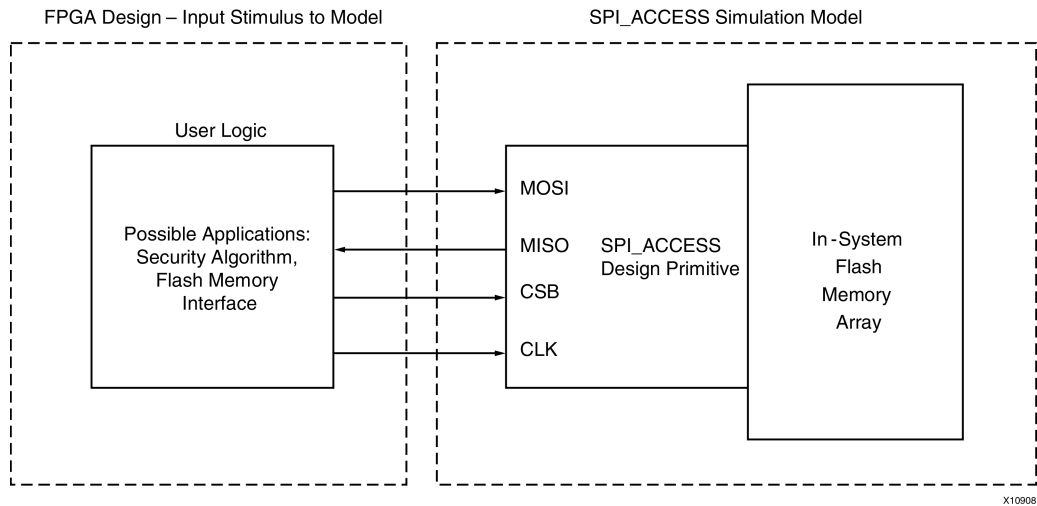

SPI_ACCESS Supported Commands

The **SPI_ACCESS** simulation model supports only a subset of the total commands that can be run in hardware. The commands that are supported in the model are shown in the table below. These have been tested and verified to work in the model and on silicon. All other commands are not supported in the simulation model, though they will work as expected in hardware and are still discussed in other documentation. For a complete explanation of all commands, see the [Spartan-3AN FPGA In-System Flash User Guide](#).

SPI_ACCESS Supported Commands

Command	Common Application	Hex Command Code
Fast Read	Reading a large block of contiguous data, if CLK frequency is above 33 MHz	0x0B
Random Read	Reading bytes from randomly-addressed locations, all read operations at 33 MHz or less	0x03
Status Register Read	Check ready/busy for programming commands, result of compare, protection, addressing mode, and similar	0xD7
Information Read	Read JEDEC Manufacturer and Device ID	0x9F
Security Register Read	Performs a read on the contents of the security register.	0x77
Security Register Program	Programs the User-Defined Field in the Security Register	0x9B
Buffer Write	Write data to SRAM page buffer; when complete, transfer to ISF memory using Buffer to Page Program command	Buffer1- 0x84

Command	Common Application	Hex Command Code
Buffer2- 0x87	Buffer to Page Program with Built-in Erase	First erases selected memory page and programs page with data from designated buffer
Buffer1- 0x83	Buffer2- 0x86	Buffer to Page Program without Built-in Erase
Program a previously erased page with data from designated buffer	Buffer1- 0x88	Buffer2- 0x89
Page Program Through Buffer with Erase	Combines Buffer Write with Buffer to Page Program with Built-in Erase command	Buffer1- 0x82
Buffer2- 0x85	Page to Buffer Compare	Verify that the ISF memory array was programmed correctly
Buffer1- 0x60	Buffer2- 0x61	Page to Buffer Transfer
Transfers the entire contents of a selected ISF memory page to the specified SRAM page buffer	Buffer1- 0x53	Buffer2- 0x55
Sector Erase	Erases any unprotected, unlocked sector in the main memory	0x7C
Page Erase	Erases any individual page in the ISF memory array	0x81

SPI_ACCESS Memory Initialization

The user-created memory file used to initialize the ISF is a list of Hex bytes in ASCII format. The file should have one ASCII coded hex byte on each line, where the number of lines is decided by the memory size. The file initializes the ISF memory space.

If the size of the memory in the file does not match the size of the memory for the device, a message warns that the file is either too large or too small.

- If the initialization file is too short, the rest of the memory is filled with 0xFF.
- If the initialization file is too long, the unneeded bytes are left unused.

The following table shows the memory size available for each of the devices.

ISF Available Memory Size

Device	ISF Memory Bits	Available User Memory (Bytes)	Lines in Initialization File
3S50AN	1M +	135,168	135,168
3S200AN	4M +	540,672	540,672
3S400AN	4M +	540,672	540,672
3S700AN	8M +	1,081,344	1,081,344
3S1400AN	16M +	2,162,688	2,162,688

SPI_ACCESS Attributes

Five attributes can be set for the `SPI_ACCESS` component.

- `SPI_ACCESS SIM_DEVICE`
- `SPI_ACCESS SIM_USER_ID`
- `SPI_ACCESS SIM_MEM_FILE`
- `SPI_ACCESS SIM_FACTORY_ID`
- `SPI_ACCESS SIM_DELAY_TYPE`

SPI_ACCESS SIM_DEVICE Attribute

`SIM_DEVICE` defines which Spartan-3AN device you are using. This allows the proper SPI Flash size to be set. `SIM_DEVICE` is required

SPI_ACCESS SIM_USER_ID Attribute

`SIM_USER_ID` is used in simulation to initialize the User-Defined Field of the Security Register. In hardware, it can be programmed with any value at any time. This field is one-time programmable (OTP). The default delivered state is erased, and all locations are `0xFF`. `SIM_USER_ID` is a 512 bit reg in Verilog and a 512 bit `bit_vector` in VHDL with the exact hex values you want in simulation. Bit 511 is the first bit out of the user portion of the security register. Bit 0 is the last bit out of the user portion of the security register.

SPI_ACCESS SIM_MEM_FILE Attribute

`SIM_MEM_FILE` specifies the file and directory name of the memory initialization file. For more information, see `SPI_ACCESS` Memory Initialization.

SPI_ACCESS SIM_FACTORY_ID Attribute

`SIM_FACTORY_ID` is used for simulation purposes only. `SIM_FACTORY_ID` allows you to set a unique value to the Unique Identifier portion of the security register. This value is read back by sending an Information Read command. The default for the Factory ID is all `ones`.

In simulation, the `FACTORY_ID` can be written only once. As soon as a value other than `one` is detected in the factory ID, no further writing is allowed.

In the hardware, each individual device has a unique factory programmed ID in this field. It cannot be reprogrammed or erased.

SPI_ACCESS SIM_DELAY_TYPE Attribute

`SIM_DELAY_TYPE` is used to scale the chip delays down to more reasonable values for simulation. If `SIM_DELAY_TYPE` is set to `ACCURATE`, the model enforces the real timing specifications such as five (5) seconds for sector erase. If `SIM_DELAY_TYPE` is set to `SCALED`, it enforces much shorter time delays which are scaled back for faster simulation runtimes. The device behavior is not affected.

SPI_ACCESS Available Attributes

Attribute	Type	Allowed Values	Default	Description
SIM_DEVICE	String	3S50AN 3S200AN 3S400AN 3S700AN 3S1400AN	3S1400AN	Specifies the target device so that the proper size SPI Memory is used. This attribute should be modified to match the device under test.
SIM_USER_ID	64-byte Hex Value	Any 64-byte hex value	All locations default to 0xFF	Specifies the programmed USER ID in the Security Register for the SPI Memory
SIM_MEM_FILE	String	Specified file and directory name	NONE	Optionally specifies a hex file containing the initialization memory content for the SPI Memory
SIM_FACTORY_ID	64-byte Hex Value	Any 64-byte Hex Value	All locations default to 0xFF	Specifies the Unique Identifier value in the Security Register for simulation purposes (the actual HW value will be specific to the particular device used).
SIM_DELAY_TYPE	String	ACCURATE SCALED	SCALED	Scales down some timing delays for faster simulation run. ACCURATE = timing and delays consistent with datasheet specs. SCALED = timing numbers scaled back to run faster simulation, behavior not affected.

For more information on using the **SPI_ACCESS** primitive, see the *Libraries Guides*.

Disabling BlockRAM Collision Checks for Simulation

Xilinx® block RAM memory is a true dual-port RAM where both ports can access any memory location at any time. Be sure that the same address space is not accessed for reading and writing at the same time. This will cause a block RAM address collision. These are valid collisions, since the data that is read on the read port is not valid. In the hardware, the value that is read might be the old data, the new data, or a combination of the old data and the new data. In simulation, this is modeled by outputting X since the value read is unknown. For more information on block RAM collisions, see the [Device User Guide](#).

In certain applications, this situation cannot be avoided or designed around. In these cases, the block RAM can be configured not to look for these violations. This is controlled by the generic (VHDL) or parameter (Verilog) `SIM_COLLISION_CHECK` in all the Xilinx block RAM primitives.

SIM_COLLISION_CHECK Strings

Use the strings shown in the following table to control what happens in the event of a collision.

SIM_COLLISION_CHECK Strings

String	Write Collision Messages	Write Xs on the Output
<code>ALL</code>	Yes	Yes
<code>WARN_ONLY</code>	Yes	No Applies only at the time of collision. Subsequent reads of the same address space may produce Xs on the output.
<code>GENERATE_X_ONLY</code>	No	Yes
None	No	No Applies only at the time of collision. Subsequent reads of the same address space may produce Xs on the output.

`SIM_COLLISION_CHECK` can be applied at an instance level. This enables you to change the setting for each block RAM instance.

Global Reset and Tristate for Simulation

Xilinx® FPGA devices have dedicated routing and circuitry that connects to every register in the device. The dedicated Global Set/Reset (GSR) net is asserted, and is released during configuration immediately after the device is configured. All the flip-flops and latches receive this reset, and are either set or reset, depending on how the registers are defined.

Although you can access the GSR net after configuration, Xilinx does not recommend using the GSR circuitry in place of a manual reset. This is because the FPGA devices offer high-speed backbone routing for high fanout signals such as a system reset. This backbone route is faster than the dedicated GSR circuitry, and is easier to analyze than the dedicated global routing that transports the GSR signal.

In back-end simulations, a GSR signal is automatically pulsed for the first 100 ns to simulate the reset that occurs after configuration. A GSR pulse can optionally be supplied in front end functional simulations, but is not necessary if the design has a local reset that resets all registers. When you create a test bench, remember that the GSR pulse occurs automatically in the back-end simulation. This holds all registers in reset for the first 100 ns of the simulation.

In addition to the dedicated global GSR, all output buffers are set to a high impedance state during configuration mode with the dedicated Global Tristate (GTS) net. All general-purpose outputs are affected whether they are regular, tristate, or bi-directional outputs during normal operation. This ensures that the outputs do not erroneously drive other devices as the FPGA device is configured.

In simulation, the GTS signal is usually not driven. The circuitry for driving GTS is available in the back-end simulation and can be optionally added for the front end simulation, but the GTS pulse width is set to 0 by default.

Using Global Tristate (GTS) and Global Set/Reset (GSR) Signals in an FPGA Device

The following diagram shows how Global Tristate (GTS) and Global Set/Reset (GSR) signals are used in an FPGA device.

Built-in FPGA Initialization Circuitry Diagram

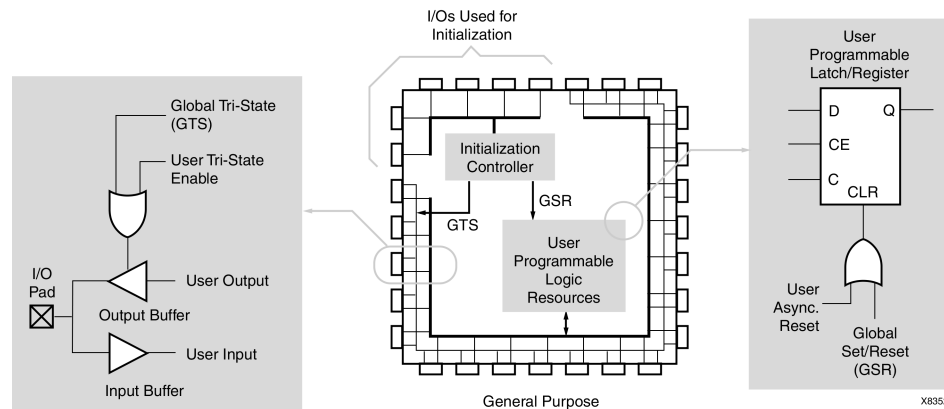

Global Set/Reset (GSR) and Global Tristate (GTS) in Verilog

The Global Set/Reset (GSR) and Global Tristate (GTS) signals are defined in the `$XILINX/verilog/src/glbl.v` module.

Since the `glbl.v` module connects the global signals to the design, it is necessary to compile this module with the other design files and load it along with the `design.v` file and the `testfixture.v` file for simulation.

In most cases, GSR and GTS need not be defined in the test bench. The `glbl.v` file declares the global GSR and GTS signals and automatically pulses GSR for 100 ns. This is all that is necessary for back-end simulations, and is usually all that is necessary for functional simulations.

Design Hierarchy and Simulation

Hierarchy:

- Makes the design easier to read
- Makes the design easier to re-use
- Allows partitioning for a multi-engineer team
- Improves verification

Improving Design Utilization and Performance

To improve design utilization and performance, the synthesis tool or the Xilinx® implementation tools often flatten or modify the design hierarchy. After this flattening and restructuring of the design hierarchy in synthesis and implementation, it may become impossible to reconstruct the hierarchy.

As a result, much of the advantage of using the original design hierarchy in Register Transfer Level (RTL) verification is lost in back-end verification. In order to improve visibility of the design for back-end simulation, the Xilinx design flow allows for retention of the original design hierarchy.

To preserve the design hierarchy through implementation with little or no degradation in performance or increase in design resources:

- Follow stricter design rules.
- Select the design hierarchy so that optimization is not necessary across the design hierarchy.

Good Design Practices

For optimal designs:

- Register all outputs exiting a preserved entity or module.
- Do not allow critical timing paths to span multiple entities or modules.
- Keep related or possibly shared logic in the same entity or module.
- Place all logic that is to be placed or merged into the I/O (such as Input Output Block (IOB) registers, tristate buffers, and instantiated I/O buffers) in the top-level module or entity for the design. This includes double-data rate registers used in the I/O.
- Manually duplicate high-fanout registers at hierarchy boundaries if improved timing is necessary.

Maintaining the Hierarchy

To maintain the entire hierarchy (or specified parts of the hierarchy) during synthesis, you must first instruct the synthesis tool to preserve hierarchy for all levels (or for each selected level of hierarchy). This may be done with:

- A global switch
- A compiler directive in the source files
- A synthesis command

For more information on how to retain hierarchy, see your synthesis tool documentation.

After taking the necessary steps to preserve hierarchy, and properly synthesizing the design, the synthesis tool creates a hierarchical implementation file (Electronic Data Interchange Format (EDIF) or NGC) that retains the hierarchy.

Before implementing the design with the Xilinx® software, place a Keep Hierarchy constraint on each instance in the design in which the hierarchy is to be preserved. Keep Hierarchy tells the Xilinx software which parts of the design should not be flattened or modified to maintain proper hierarchy boundaries.

Keep Hierarchy may be passed in the source code as an attribute, as an instance constraint in the Netlist Constraints File (NCF) or User Constraints File (UCF), or may be automatically generated by the synthesis tool.

For more information, see your synthesis tool documentation.

For more information on Keep Hierarchy, see the [Constraints Guide](#).

After the design is mapped, placed, and routed, run NetGen using the following parameters to properly back-annotate the hierarchy of the design.

```
netgen -sim -ofmt {vhdl|verilog} design_name.ncd netlist_name
```

This is the NetGen default when you use ISE® Design Suite or XFLOW to generate the simulation files. It is necessary to know this only if you plan to execute NetGen outside of ISE Design Suite or XFLOW, or if you have modified the default options in ISE Design Suite or XFLOW. When you run NetGen in the preceding manner, all hierarchy that was specified to Keep Hierarchy is reconstructed in the resulting VHDL or Verilog netlist.

NetGen can write out a separate netlist file and Standard Delay Format (SDF) file for each level of preserved hierarchy. This capability allows for full timing simulation of individual portions of the design, which in turn allows for:

- Greater test bench re-use
- Team-based verification methods
- The potential for reduced overall verification times

Use the `-mhf` switch to produce individual files for each Keep Hierarchy instance in the design. You can also use the `-mhf` switch together with the `-dir` switch to place all associated files in a separate directory.

```
netgen -sim -ofmt {vhdl|verilog} -mhf -dir directory_name
design_name.ncd
```

When you run NetGen with the `-mhf` switch, NetGen produces a text file called `design_mhf_info.txt`. The `design_mhf_info.txt` file lists all produced module and entity names, their associated instance names, Standard Delay Format (SDF) files, and sub modules. The `design_mhf_info.txt` file is useful for determining proper simulation compile order, SDF annotation options, and other information when you use one or more of these files for simulation.

Example mhf_info.txt File

Following is an example of an `mhf_info.txt` file for a VHDL produced netlist:

```
// Xilinx design hierarchy information file produced by netgen
// The information in this file is useful for
//   - Design hierarchy relationship between modules
//   - Bottom up compilation order (VHDL simulation)
//   - SDF file annotation (VHDL simulation)
//
// Design Name : stopwatch
//
// Module      : The name of the hierarchical design module.
// Instance    : The instance name used in the parent module.
// Design File : The name of the file that contains the module.
// SDF File    : The SDF file associated with the module.
// SubModule   : The sub module(s) contained within a given module.
//             Module, Instance : The sub module and instance names.
```

```
Module      : hex2led_1
Instance    : msbled
Design File : hex2led_1_sim.vhd
SDF File    : hex2led_1_sim.sdf
SubModule   : NONE

Module      : hex2led
Instance    : lsbled
Design File : hex2led_sim.vhd
SDF File    : hex2led_sim.sdf
SubModule   : NONE

Module      : smallcntr_1
Instance    : lsbcount
Design File : smallcntr_1_sim.vhd
SDF File    : smallcntr_1_sim.sdf
SubModule   : NONE

Module      : smallcntr
Instance    : msbcount
Design File : smallcntr_sim.vhd
SDF File    : smallcntr_sim.sdf
SubModule   : NONE

Module      : cnt60
Instance    : sixty
Design File : cnt60_sim.vhd
SDF File    : cnt60_sim.sdf
SubModule   : smallcntr, smallcntr_1
              Module : smallcntr, Instance : msbcount
              Module : smallcntr_1, Instance : lsbcount

Module      : decode
Instance    : decoder
Design File : decode_sim.vhd
SDF File    : decode_sim.sdf
SubModule   : NONE

Module      : dcml
Instance    : Inst_dcml
Design File : dcml_sim.vhd
SDF File    : dcml_sim.sdf
SubModule   : NONE

Module      : statmach
Instance    : MACHINE
Design File : statmach_sim.vhd
SDF File    : statmach_sim.sdf
SubModule   : NONE

Module      : stopwatch
Design File : stopwatch_timesim.vhd
SDF File    : stopwatch_timesim.sdf
SubModule   : statmach, dcml, decode, cnt60, hex2led, hex2led_1
              Module : statmach, Instance : MACHINE
              Module : dcml, Instance : Inst_dcml
              Module : decode, Instance : decoder
              Module : cnt60, Instance : sixty
```

```
Module : hex2led, Instance : lsbled
Module : hex2led_1, Instance : msbled
```

Hierarchy created by generate statements may not match the original simulation due to naming differences between the simulator and synthesis engines for generated instances.

Register Transfer Level (RTL) Simulation Using Xilinx Libraries

Xilinx® simulation libraries can be simulated using any simulator that supports the VHDL-93 and Verilog-2001 language standards. Certain delay and modelling information is built into the libraries, which is required to correctly simulate the Xilinx hardware devices.

Do not change data signals at clock edges, even for functional simulation. The simulators add a unit delay between the signals that change at the same simulator time. If the data changes at the same time as a clock, it is possible that the data input will be scheduled by the simulator to occur after the clock edge. The data will not go through until the next clock edge, although it is possible that the intent was to have the data clocked in before the first clock edge. To avoid such unintended simulation results, do not switch data signals and clock signals simultaneously.

Delta Cycles and Race Conditions

All Xilinx® supported simulators are event-based simulators. Event-based simulators can process multiple events at a given simulation time. While these events are being processed, the simulator may not advance the simulation time. This time is commonly referred to as delta cycles. There can be multiple delta cycles in a given simulation time. Simulation time is advanced only when there are no more transactions to process. For this reason, simulators may give unexpected results. The following VHDL coding example shows how an unexpected result can occur.

VHDL Coding Example With Unexpected Results

```
clk_b <= clk;
clk_prcs : process (clk)
begin
    if (clk'event and clk='1') then
        result <= data;
    end if;
end process;

clk_b_prcs : process (clk_b)
begin
    if (clk_b'event and clk_b='1') then
        result1 <= result;
    end if;
end process;
```

In this example, there are two synchronous processes:

- `clk`
- `clk_b`

The simulator performs the `clk <= clk_b` assignment before advancing the simulation time. As a result, events that should occur in *two* clock edges will occur instead in *one* clock edge, causing a race condition.

Recommended ways to introduce causality in simulators for such cases include:

- Do not change clock and data at the same time. Insert a delay at every output.
- Be sure to use the same clock.
- Force a delta delay by using a temporary signal as follows:

```
clk_b <= clk;
  clk_prcs : process (clk)
  begin
    end if;
  end process;
  result_temp <= result;
  clk_b_prcs : process (clk_b)
  begin
    if (clk_b'event and clk_b='1') then
      result1 <= result_temp;
    end if;
  end process;
```

Almost every event-based simulator can display delta cycles. Use this to your advantage when debugging simulation issues.

Recommended Simulation Resolution

Xilinx® recommends that you run simulations using a resolution of **1ps**. Some Xilinx primitive components, such as **DCM**, require a **1ps** resolution in order to work properly in either functional or timing simulation.

There is no simulator performance gain by using coarser resolution with the Xilinx simulation models. Since much simulation time is spent in delta cycles, and delta cycles are not affected by simulator resolution, no significant simulation performance can be obtained.

Xilinx recommends that you *not* run at a finer resolution such as **fs**. Some simulators may round the numbers, while other simulators may truncate the numbers.

Picosecond is used as the minimum resolution since all testing equipment can measure timing only to the nearest **picosecond** resolution. Xilinx strongly recommends using **ps** for all Hardware Description Language (HDL) simulation purposes.

Encryption Methodology Used for SecureIP Models

Xilinx® leverages the latest encryption methodology as specified in Verilog LRM - IEEE Std 1364-2005. Device simulation models for the IP such as the PowerPC® processor, MGT, and PCIe® leverages this technology

Everything is automatically handled by means of Compplib, provided the appropriate version of the simulator is present on your computer. When running a simulation with this new methodology in Verilog, you must reference the SecureIP library.

For most simulators, this can be done by using the **-L** switch as an argument to the simulator, such as **-L secureip**. For more information, see [SecureIP Libraries](#).

For the switch to use with your simulator, see your simulator documentation.

If using VHDL as the design entry, a mixed-language license is required to run any IP simulation using this new IP Encryption Methodology.

Generating Gate-Level Netlist (Running NetGen)

NetGen can create a verification netlist file from your design files. To create a timing simulation netlist, run NetGen from any of the following:

- ISE® Design Suite

For information on creating a back-annotated simulation netlist in ISE Design Suite, see the ISE Design Suite Help.

- XFLOW

To display the available options for XFLOW, and for a complete list of the XFLOW option files, type `xflow` at the prompt without any arguments. For complete descriptions of the options and the option files, see the [Command Line Tools User Guide](#).

- Command Line or Script File

To create a simulation netlist from the command line or a script file, see the NetGen chapter in the [Command Line Tools User Guide](#).

Disabling X Propagation for Synchronous Elements

When a timing violation occurs during a timing simulation, the default behavior of a latch, register, RAM, or other synchronous element outputs an X to the simulator.

This occurs because the actual output value is not known. The output of the register could:

- Retain its previous value
- Update to the new value
- Go metastable, in which a definite value is not settled upon until some time after the clocking of the synchronous element

Since this value cannot be determined, and accurate simulation results cannot be guaranteed, the element outputs an X to represent an unknown value. The X output remains until the next clock cycle in which the next clocked value updates the output if another violation does not occur.

X generation can significantly affect simulation. For example, an X generated by one register can be propagated to others on subsequent clock cycles. This may cause large portions of the design being tested to become unknown. To correct this:

- On a synchronous path, analyze the path and fix any timing problems associated with this or other paths to ensure a properly operating circuit.
- On an asynchronous path, if you cannot otherwise avoid timing violations, disable the X propagation on synchronous elements during timing violations.

When X propagation is disabled, the previous value is retained at the output of the register. In the actual silicon, the register may have changed to the 'new' value. Disabling X propagation may yield simulation results that do not match the silicon behavior.

Caution! Exercise care when using this option. Use it only if you cannot otherwise avoid timing violations.

Using the ASYNC_REG Constraint

The `ASYNC_REG` constraint:

- Identifies asynchronous registers in the design
- Disables X propagation for those registers

ASYNC_REG can be attached to a register in the front end design by:

- An attribute in the Hardware Description Language (HDL) code, or
- A constraint in the User Constraints File (UCF)

The registers to which **ASYNC_REG** is attached retain the previous value during timing simulation, and do not output an X to simulation.

A timing violation error may still occur. Use care, as the new value may have been clocked in as well.

ASYNC_REG is applicable to **CLB** and Input Output Block (IOB) registers and latches only. If you cannot avoid clocking in asynchronous data, Xilinx® recommends that you do so for **IOB** or **CLB** registers only. Clocking in asynchronous signals to **RAM**, Shift Register LUT (SRL), or other synchronous elements has less deterministic results, and therefore should be avoided.

Xilinx highly recommends that you first properly synchronize any asynchronous signal in a register, latch, or **FIFO** before writing to a **RAM**, Shift Register LUT (SRL), or any other synchronous element.

For more information, see the [Constraints Guide](#).

MIN/TYP/MAX Simulation

The Standard Delay Format (SDF) file allows you to specify three sets of delay values for simulation:

- Minimum (**MIN**)
- Typical (**TYP**)
- Maximum (**MAX**)

Xilinx® uses these values to allow the simulation of the target architecture under various operating conditions. By allowing for the simulation across various operating conditions, you can perform more accurate setup and hold timing verification.

Minimum (MIN)

Minimum (**MIN**) represents the device under the best case operating conditions. The base case operating conditions are defined as the minimum operating temperature, the maximum voltage, and the best case process variations. Under best case conditions, the data paths of the device have the minimum delay possible, while the clock path delays are the maximum possible relative to the data path delays. This situation is ideal for hold time verification of the device.

Typical (TYP)

Typical (**TYP**) represents the typical operating conditions of the device. In this situation, the clock and data path delays are both the maximum possible. This is different from the Maximum (**MAX**) field, in which the clock paths are the minimum possible relative to the maximum data paths. Xilinx generated Standard Delay Format (SDF) files do not take advantage of this field.

Maximum (MAX)

Maximum (**MAX**) represents the delays under the worst case operating conditions of the device. The worst case operating conditions are defined as the maximum operating temperature, the minimum voltage, and the worst case process variations. Under worst case conditions, the data paths of the device have the maximum delay possible, while the clock path delays are the minimum possible relative to the data path delays. This situation is ideal for setup time verification of the device.

Obtaining Accurate Timing Simulation Results

Run the following to obtain the most accurate setup and hold timing simulations:

- NetGen
- Setup Simulation
- Hold Simulation

Run NetGen

To obtain accurate Standard Delay Format (SDF) numbers, run **netgen** with **-pcf** pointing to a valid Physical Constraints File (PCF). NetGen must be run with **-pcf** since newer Xilinx® devices take advantage of relative mins for timing information. Once **netgen** is called with **-pcf** the Minimum (**MIN**) and Maximum (**MAX**) numbers in the SDF file will be different for the components.

Once the correct SDF file is created, two types of simulation must be run for complete timing closure:

- Setup Simulation
- Hold Simulation

In order to run the different simulations, the simulator must be called with the appropriate switches.

Run Setup Simulation

To perform a Setup Simulation, specify values in the Maximum (**MAX**) field with the **-SDFMAX** command line option.

Run Hold Simulation

To perform the most accurate Hold Simulation, specify values in the Minimum (**MIN**) field with the **-SDFMIN** command line option.

For more information on passing the SDF switches to the simulator, see your simulator tool documentation.

Absolute Min Simulation

NetGen can optionally produce absolute minimum delay values for simulation by applying the **-s min** switch. The resulting Standard Delay Format (SDF) file has the absolute process minimums populated in all three SDF fields:

- Minimum (**MIN**)
- Typical (**TYP**)
- Maximum (**MAX**)

Absolute process Minimum (**MIN**) values are the absolute fastest delays that a path can run in the target architecture given the best operating conditions within the specifications of the architecture:

- Lowest temperature
- Highest voltage
- Best possible silicon

Generally, these process minimum delay values are only useful for checking board-level, chip-to-chip timing for high-speed data paths in best case and worst case conditions.

By default, the worst case delay values are derived from the worst temperature, voltage, and silicon process for a particular target architecture. If better temperature and voltage characteristics can be ensured during the operation of the circuit, you can use prorated worst case values in the simulation to gain better performance results.

The default applies worst case timing values over the specified **TEMPERATURE** and **VOLTAGE** within the operating conditions recommended for the device. For more information on the **TEMPERATURE** and **VOLTAGE** constraints, see the [Constraints Guide](#).

NetGen generates a Standard Delay Format (SDF) file with Minimum (**MIN**) numbers only for devices that support absolute min timing numbers.

Using the **VOLTAGE** and **TEMPERATURE** Constraints

Prorating is a linear scaling operation. It applies to existing speed file delays, and is applied globally to all delays. The prorating constraints, **VOLTAGE** and **TEMPERATURE**, provide a method for determining timing delay characteristics based on known environmental parameters.

For more information on the **VOLTAGE** and **TEMPERATURE** constraints, see the [Constraints Guide](#).

Using the **VOLTAGE** Constraint

The **VOLTAGE** constraint provides a means of prorating delay characteristics based on the specified voltage applied to the device. The User Constraints File (UCF) syntax is:

```
VOLTAGE=value[units]
```

where

- *value* is an integer or real number specifying the voltage
- *units* is an optional parameter specifying the unit of measure.

Using the **TEMPERATURE** Constraint

The **TEMPERATURE** constraint provides a means of prorating device delay characteristics based on the specified junction temperature. The UCF syntax is:

```
TEMPERATURE=value[C|F|K]
```

where

- *value*
is an integer or a real number specifying the temperature
- *C*, *F*, and *K* are the temperature units
 - *C* = degrees Celsius (default)
 - *F* = degrees Fahrenheit
 - *K* = degrees Kelvin

The resulting values in the Standard Delay Format (SDF) fields when using prorated **VOLTAGE** and **TEMPERATURE** values are the prorated worst case values.

Determining Valid Operating Temperatures and Voltages

To determine the specific range of valid operating temperatures and voltages for the target architecture, see the device [data sheet](#). If the temperature or voltage specified in the constraint does not fall within the supported range, the constraint is ignored and an architecture specific default value is used instead.

Not all architectures support prorated timing values. For simulation, the **VOLTAGE** and **TEMPERATURE** constraints are processed from the User Constraints File (UCF) into the Physical Constraints File (PCF). The PCF must then be referenced when running NetGen in order to pass the operating conditions to the delay annotator.

To generate a simulation netlist using prorating for VHDL, type:

```
netgen -sim -ofmt vhdl [options] -pcf design.pcf design.ncd
```

To generate a simulation netlist using prorating for Verilog, type:

```
netgen -sim -ofmt verilog [options] -pcf design.pcf design.ncd
```

Combining both minimum values overrides prorating, and results in issuing only absolute process **MIN** values for the simulation Standard Delay Format (SDF) file.

Prorating is available for certain FPGA devices only. It is not intended for military and industrial ranges. It is applicable only within commercial operating ranges.

NetGen Options for Different Delay Values

NetGen Option	MIN:TYP:MAX Field in SDF File Produced by netgen -sim
-pcf <pcf_file>	MIN:MIN(Hold time) TYP:TYP(Ignore) MAX:MAX(Setup time)
default	MAX:MAX:MAX
-s min	Process MIN: Process MIN: Process MIN
Prorated voltage or temperature in User Constraints File (UCF) or Physical Constraints File (PCF)	Prorated MAX: Prorated MAX: Prorated MAX

Special Considerations for DCM, DLL, and MMCM

Following are special considerations for **CLKDLL**, **DCM**, and **DCM_ADV**:

- [DLL/DCM Clocks Do Not Appear De-Skewed](#)
- [TRACE/Simulation Model Differences for DCM/DLL](#)
- [Non-LVTTL Input Drivers](#)
- [Viewer Considerations](#)
- [Attributes for Simulation and Implementation](#)
- [Understanding Timing Simulation](#)

DLL/DCM Clocks Do Not Appear De-Skewed

The **DLL** and **DCM** components remove the clock delay from the clock entering into the chip. As a result, the incoming clock and the clocks feeding the registers in the device have a minimal skew within the range specified in the databook for any given device. In timing simulation, the clocks may not appear to be de-skewed within the range specified. This is due to the way the delays in the Standard Delay Format (SDF) file are handled by some simulators.

The SDF file annotates the **CLOCK PORT** delay on the **X_FF** components. Some simulators may show the clock signal in the waveform viewer before taking this delay into account. If the simulator is not properly de-skewing the clock, see your simulator tool documentation to determine if your simulator tool is displaying the input port delays in the waveform viewer at the input nodes. If so, when the **CLOCK PORT** delay on the **X_FF** is added to the internal clock signal, it should line up within the device specifications in the waveform viewer with the input port clock. The simulation is still functioning properly, the waveform viewer is just not displaying the signal at the expected node. To verify that the **DLL/DCM** is functioning correctly, delays from the SDF file may need to be accounted for manually to calculate the actual skew between the input and internal clocks.

TRACE/Simulation Model Differences for DCM/DLL

To fully understand the simulation model, you must understand that there are differences in the way:

- **DLL/DCM** is built in silicon
- TRACE reports their timing
- **DLL/DCM** is modeled for simulation

The **DLL/DCM** simulation model attempts to replicate the functionality of the **DLL/DCM** in the Xilinx® silicon, but it does not always do it exactly how it is implemented in the silicon. In the silicon, the **DLL/DCM** uses a tapped delay line to delay the clock signal. This accounts for input delay paths and global buffer delay paths to the feedback in order to accomplish the proper clock phase adjustment. TRACE or Timing Analyzer reports the phase adjustment as a simple delay (usually negative) so that you can adjust the clock timing for static timing analysis.

As for simulation, the **DLL/DCM** simulation model itself attempts to align the input clock to the clock coming back into the feedback input. Instead of putting the delay in the **DLL** or **DCM** itself, the delays are handled by combining some of them into the feedback path as clock delay on the clock buffer (component) and clock net (port delay). The remainder is combined with the port delay of the **CLKFB** pin. While this is different from the way TRACE or Timing Analyzer reports it, and the way it is implemented in the silicon, the end result is the same functionality and timing. TRACE and simulation both use a simple delay model rather than an adjustable delay tap line similar to silicon.

The primary function of the **DLL/DCM** is to remove the clock delay from the internal clocking circuit as shown in the following diagram.

Delay Locked Loop Block Diagram

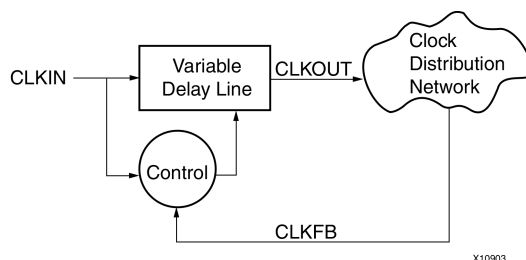

Do not confuse this with de-skewing the clock. Clock skew is generally associated with delay variances in the clock tree, which is a different matter. By removing the clock delay, the input clock to the device pin should be properly phase aligned with the clock signal as it arrives at each register it is sourcing. Observing signals at the **DLL/DCM** pins generally does not give the proper viewpoint to observe the removal of the clock delay.

To determine if the **DCM** is functioning as intended, compare the input clock (at the input port to the design) with the clock pins of one of the sourcing registers. If these are aligned (or shifted to the desired amount), then the **DLL/DCM** is functioning as intended.

Non-LVTTL Input Drivers

When non-LVTTL input buffer drivers drive the clock, the DCM does not adjust for the type of input buffer. Instead, the DCM has a single delay value to provide the optimal amount of clock delay across all I/O standards. If you are using the same input standard for the data, the delay values should track, and usually not cause a problem.

Even if you are not using the same input standard, the amount of delay variance usually does not cause hold time failures. The delay variance is small compared to the amount of input delay. The delay variance is calculated in both static timing analysis and simulation. Proper setup time values should occur during both static timing analysis and simulation.

Viewer Considerations

Depending on the simulator, the waveform viewer may not depict the delay timing in the expected manner. Some simulators (including ModelSim) combine interconnect and port delays with the input pins of the component delays. While the simulation results are correct, the depiction in the waveform viewer may be unexpected.

Since interconnect delays are combined, when you look at a pin using the ModelSim viewer, you do not see the transition as it happens on the pin. The simulation acts properly, but when attempting to calculate clock delay, the interconnect delays before the clock pin must be taken into account if the simulator you are using combines these interconnect delays with component delays.

Attributes for Simulation and Implementation

Make sure that the same attributes are passed for simulation and implementation. During implementation, **DLL/DCM** attributes may be passed by:

- The synthesis tool (generic or inline parameter declaration)
- The User Constraints File (UCF)

For Register Transfer Level (RTL) simulation of the UNISIM models, the simulation attributes must be passed by means of:

- A generic (VHDL)
- Inline parameters (Verilog)

If you do not use the default setting for the **DLL/DCM**, make sure that the attributes for RTL simulation are the same as those used for implementation. If not, there may be differences between RTL simulation and the actual device implementation.

To make sure that the attributes passed to implementation are the same as those used for simulation, use the generic mapping method (VHDL) or inline parameter passing (Verilog), provided your synthesis tool supports these methods for passing functional attributes.

Understanding Timing Simulation

In back annotated (timing) simulation, the introduction of delays can cause the behavior to differ from what is expected. Most problems are caused by timing violations in the design, and are reported by the simulator. There are a few other situations that can occur as discussed in this section.

Importance of Timing Simulation

FPGA devices require both functional and timing simulation to ensure successful designs. FPGA designs are growing in complexity. Traditional verification methodologies are no longer sufficient. In the past, simulation was not an important stage in the FPGA design flow. Currently simulation is becoming one of the most critical stages. Timing simulation is especially important when designing for advanced FPGA devices.

Functional Simulation

While functional simulation is an important part of the verification process, it should not be the only part. Functional simulation tests only for the functional capabilities of the Register Transfer Level (RTL) design. It does not include any timing information, nor does it take into consideration changes made to the original design due to implementation and optimization

Static Timing Analysis and Equivalency Checking

Many designers see Static Timing Analysis and Equivalency Checking as the only analysis needed to verify that the design meets timing. There are many drawbacks to using Static Timing Analysis and Equivalency Checking as the only timing analysis methodology. Static analysis cannot find any of the problems that can be seen when running a design dynamically. It can only show if the design as a whole meets setup and hold requirements. It is generally only as good as the timing constraints applied.

In a real system, dynamic factors such as Block Ram collisions can cause timing violations on the FPGA device. With the introduction of Dual Port Block Rams in FPGA devices, care should be taken not to read and write to the same location at the same time, as this results in incorrect data being read back. Static analysis is unable to find this problem. Similarly, if there are misconstrued timespecs, static timing analysis cannot find this problem.

In-System Testing

Most designers rely on In-System Testing as the ultimate test. If the design works on the board, and passes the test suites, they view the device as ready for release. While In-System Testing is definitely effective for some purposes, it may not immediately detect all potential problems. At times the design must be run for a lengthy period before corner-case issues become apparent. For example, issues such as timing violations may not become apparent in the same way in all devices. By the time these corner-case issues manifest themselves, the design may already be in the hands of the end customer. It will mean high costs, downtime, and frustration to try to resolve the problem. In order to properly complete In-System Testing, all hardware hurdles such as problems with SSO, Cross-talk, and other board related issues must be overcome. Any external interfaces must also be connected before beginning the In-System Testing, increasing the time to market.

The traditional methods of verification are not sufficient for a fully verified system. There are compelling reasons to do dynamic timing analysis.

Glitches in Your Design

When a glitch (small pulse) occurs in an FPGA circuit or any integrated circuit, the glitch may be passed along by the transistors and interconnect (transport) in the circuit, or it may be swallowed and not passed (internal) to the next resource in the FPGA device. This depends on the width of the glitch and the type of resource the glitch passes through. To produce more accurate simulation of how signals are propagated within the silicon, Xilinx® models this behavior in the timing simulation netlist.

VHDL Simulation

For VHDL simulation, library components are instantiated by NetGen and proper values are annotated for pulse rejection in the simulation netlist. The result of these constructs in the simulation netlists is a more true-to-life simulation model, and therefore a more accurate simulation.

Verilog Simulation

For Verilog simulation, this information is passed by the **PATHPULSE** construct in the Standard Delay Format (SDF) file. This construct is used to specify the size of pulses to be rejected or swallowed on components in the netlist.

Debugging Timing Problems

In back-annotated (timing) simulation, the simulator processes timing information in the Standard Delay Format (SDF) file. This may cause timing violations if the circuit is operated too fast, or if there are asynchronous components in the design.

This section explains some common timing violations, and gives recommendations on how to debug and correct them.

After you run timing simulation, review any warning or error messages generated by your simulator.

The following example is a typical setup violation message from ModelSim for a Verilog design. Message formats vary from simulator to simulator, but all contain the same basic information. For more information, see your simulator tool documentation.

```
# ** Error:/path/to/xilinx/verilog/src/simprims/X_RAMD16.v(96):
$setup(negedge WE:29138 ps, posedge CLK:29151 ps, 373 ps);
# Time:29151 ps Iteration:0 Instance: /test_bench/u1/\U1/X_RAMD16\
```

Setup Violation Message Line One

```
# ** Error:/path/to/xilinx/verilog/src/simprims/X_RAMD16.v(96):
```

Line One points to the line in the simulation model that is in error. In this example, the failing line is line 96 of the Verilog file X_RAMD16.

Setup Violation Message Line Two

```
$setup(negedge WE:29138 ps, posedge CLK:29151 ps, 373 ps);
```

Line Two gives information about the two signals that caused the error:

- The type of violation, such as **\$setup**, **\$hold**, or **\$recovery**. This example is a **\$setup** violation.
- The name of each signal involved in the violation, followed by the simulation time at which that signal last changed values. In this example, the failing signals are the negative-going edge of the signal **WE**, which last changed at 29138 picoseconds, and the positive-going edge of the signal **CLK**, which last changed at 29151 picoseconds.
- The allotted amount of time for the setup. In this example, the signal on **WE** should be stable for 373 pico seconds before the clock transitions. Since **WE** changed only 13 pico seconds before the clock, the simulator reported a violation.

Setup Violation Message Line Three

```
# Time:29151 ps Iteration:0 Instance: /test_bench/u1/\U1/X_RAMD16\
```

Line Three gives the simulation time at which the error was reported, and the instance in the structural design (**time_sim**) in which the violation occurred.

Timing Problem Root Causes

Timing violations, such as **\$setuphold**, occur any time data changes at a register input (either data or clock enable) within the setup or hold time window for that particular register. The most typical causes for timing violations are:

- Simulation Clock Does Not Meet Timespec
- Unaccounted Clock Skew
- Asynchronous Inputs, Asynchronous Clock Domains, Crossing Out-of-Phase

Simulation Clock Does Not Meet Timespec

If the frequency of the clock specified during simulation is greater than the frequency of the clock specified in the timing constraints, this over-clocking can cause timing violations. For example, if the simulation clock has a frequency of 5 ns, and a **PERIOD** constraint is set at 10 ns, a timing violation can occur. This situation can also be complicated by the presence of **DLL** or **DCM** in the clock path.

This problem is usually caused either by an error in the test bench or by an error in the constraint specification. Make sure that the constraints match the conditions in the test bench, and correct any inconsistencies. If you modify the constraints, re-run the design through place and route to make sure that all constraints are met.

Unaccounted Clock Skew

Clock skew is the difference between the amount of time the clock signal takes to reach the destination register, and the amount of time the clock signal takes to reach the source register. The data must reach the destination register within a single clock period plus or minus the amount of clock skew. While clock skew is usually not a problem when you use global buffers, it can be a concern if you use the local routing network for your clock signals.

To determine if clock skew is the problem, run a setup test in TRACE and read the report. For directions on how to run a setup check, see TRACE in the [Command Line Tools User Guide](#). For information on using Timing Analyzer to determine clock skew, see Timing Analyzer in the ISE® Design Suite Help.

Asynchronous Inputs, Asynchronous Clock Domains, Crossing Out-of-Phase

Timing violations can be caused by data paths that:

- Are not controlled by the simulation clock
- Are not clock controlled at all
- Cross asynchronous clock boundaries
- Have asynchronous inputs
- Cross data paths out of phase

Asynchronous Clocks

If the design has two or more clock domains, any path that crosses data from one domain to another can cause timing problems. Although data paths that cross from one clock domain to another are not always asynchronous, it is always best to be cautious.

Always treat the following as asynchronous:

- Two clocks with unrelated frequencies
- Any clocking signal coming from off-chip
- Any time a register's clock is gated (unless extreme caution is used)

To see if the path in question crosses asynchronous clock boundaries, check the source code and the Timing Analysis report. If your design does not allow enough time for the path to be properly clocked into the other domain, you may need to redesign your clocking scheme. Consider using an asynchronous FIFO as a better way to pass data from one clock domain to another.

Asynchronous Inputs

Data paths that are not controlled by a clocked element are asynchronous inputs. Because they are not clock controlled, they can easily violate setup and hold time specifications.

Check the source code to see if the path in question is synchronous to the input register. If synchronization is not possible, you can use the `ASYNC_REG` constraint to work around the problem. For more information, see [Using the ASYNC_REG Constraint](#).

Out of Phase Data Paths

Data paths can be clock controlled at the same frequency, but nevertheless can have setup or hold violations because the clocks are out of phase. Even if the clock frequencies are a derivative of each other, improper phase alignment could cause setup violations.

To see if the path in question crosses another path with an out of phase clock, check the source code and the Timing Analysis report.

Debugging Tips

When you have a timing violation, ask:

- Was the clock path analyzed by TRACE or Timing Analyzer?
- Did TRACE or Timing Analyzer report that the data path can run at speeds being clocked in simulation?
- Is clock skew being accounted for in this path delay?
- Does subtracting the clock path delay from the data path delay still allow clocking speeds?
- Will slowing down the clock speeds eliminate the `$setup` or `$hold` time violations?
- Does this data path cross clock boundaries (from one clock domain to another)? Are the clocks synchronous to each other? Is there appreciable clock skew or phase difference between these clocks?
- If this path is an input path to the device, does changing the time at which the input stimulus is applied eliminate the `$setup` or `$hold` time violations?

Depending on your answers, you may need to change your design or test bench to accommodate the simulation conditions. For more information, see [Design Considerations](#).

Setup and Hold Violations

This section discusses Setup and Hold Violations, and includes:

- [Zero Hold Time Considerations](#)
- [Negative Hold Time Considerations](#)
- [RAM Considerations](#)

Zero Hold Time Considerations

While Xilinx® [data sheets](#) report that there are zero hold times on the internal registers and I/O registers with the default delay and using a global clock buffer, it is still possible to receive a `$hold` violation from the simulator. This `$hold` violation is really a `$setup` violation on the register. In order to obtain an accurate representation of the CLB delays, part of the setup time must be modeled as a hold time.

Negative Hold Time Considerations

Older Xilinx® simulation models truncate *negative hold* times and specify them as *zero hold* times. While this truncation does not cause inaccuracies in simulation, it results in a more pessimistic timing model than can actually be achieved in the FPGA device. This makes it more difficult to meet stringent timing requirements.

Negative **hold** times are now specified in the timing models. Specifying negative **hold** times provides a wider, yet more accurate, representation of the timing window. The **setup** and **hold** parameters for the synchronous models are combined into a single **setuphold** parameter. Such combining does not change the timing simulation methodology.

There are no longer separate violation messages for **setup** and **hold** when using Cadence NC-Verilog. They are combined into a single **setuphold** violation message.

RAM Considerations

This section discusses RAM Considerations for Setup and Hold Violations, and includes:

- [Timing Violations](#)
- [Collision Checking](#)
- [Hierarchy Considerations](#)

Timing Violations

Xilinx® devices contain two types of memories:

- Block RAM
- Distributed RAM

Since block RAM and distributed RAM are synchronous elements, you must take care to avoid timing violations. To guarantee proper data storage, the data input, address lines, and enables, must all be stable before the clock signal arrives.

Collision Checking

Block RAMs also perform synchronous read operations. During a read cycle, the addresses and enables must be stable before the clock signal arrives, or a timing violation may occur.

When you use block RAM in dual-port mode, take special care to avoid memory collisions. A memory collision occurs when:

1. One port is being written to, and
2. An attempt is made to either read or write to the other port at the same address at the same time (or within a very short period of time thereafter)

The model warns you if a collision occurs.

If the RAM is being read on one port as it is being written to on the other port, the model outputs an X value signifying an unknown output. If the two ports are writing data to the same address at the same time, the model can write unknown data into memory. Take special care to avoid this situation, as unknown results may occur. For the hardware documentation on collision checking, see Design Considerations: Using Block SelectRAM™ Memory, in the device [user guide](#).

You can use the generic (VHDL) or parameter (Verilog) [Disabling BlockRAM Collision Checks for Simulation](#) to disable these checks in the model.

Hierarchy Considerations

It is possible for the top-level signals to switch correctly, keeping the **setup** and **hold** times accounted for, while at the same time, an error is reported at the lowest level primitive. As the signals travel down the hierarchy to the lowest level primitive, the delays they experience can reduce the differences between them to the point that they violate the **setup** time.

To correct this problem:

1. Browse the design hierarchy, and add the signals of the instance reporting the error to the top-level waveform. Make sure that the setup time is actually being violated at the lower level.
2. Step back through the structural design until a link between a Register Transfer Level (RTL) (pre-synthesis) design path and this instance reporting the error can be determined.
3. Constrain the Register Transfer Level (RTL) path using timing constraints so that the timing violation no longer occurs. Usually, most implemented designs have a small percentage of unconstrained paths after timing constraints have been applied, and these are the ones where `$setup` and `$hold` violations usually occur.

The debugging steps for `$hold` violations and `$setup` violations are identical.

Simulation Using Xilinx Supported EDA Simulation Tools

For information on simulation using Xilinx® supported EDA simulation tools, see:

- [Simulating Xilinx Designs in ModelSim](#)
- [Simulating Xilinx Designs in IES](#)
- [Simulating Xilinx Designs in Synopsys VCS and VCS MX](#)

Design Considerations

This chapter discusses practices to consider during your design. This chapter includes:

- [Understanding the Architecture](#)
- [Clocking Resources](#)
- [Defining Timing Requirements](#)
- [Driving Synthesis](#)
- [Choosing Implementation Options](#)
- [Evaluating Critical Paths](#)
- [SmartGuide](#)

Understanding the Architecture

When you evaluate a new FPGA architecture, you must take into account the hardware features and the trade-offs that can be made in the architecture. Most designers of FPGA devices describe their designs behaviorally in a Hardware Description Language (HDL) such as VHDL or Verilog, and rely upon a synthesis tool to map to the architecture.

Keep the specific architecture in mind as you write the HDL code to ensure that the synthesis tool maps to the hardware in the most efficient way, ensuring maximum performance. Before you begin your design, Xilinx® recommends that you review the device [user guide](#) and [data sheet](#).

Slice Structure

The slice contains the basic elements for implementing both sequential and combinatorial circuits in an FPGA device. In order to minimize area and optimize performance of a design, it is important to know if a design is effectively using the slice features. Some issues to consider are:

- What basic elements are contained with a slice? What are the different configurations for each of those basic elements? For example, a look-up table (LUT) can also be configured as a distributed RAM or a shift register.
- What are the dedicated interconnects between those basic elements? For example, could the fanout of a LUT to multiple registers prevent optimal packing of a slice?
- What common inputs do the elements of a slice share such as control signals and clocks that would potentially limit its packing? Using Registers with common set/reset, clock enable, and clocks improves the packing of the design. By using logic replication, the same reset net may have multiple unique names, and prevents optimal register packing in a slice. Consider turning off Logic Replication for reset nets and clock enables in the synthesis flow.
- What is the size of the LUT, and how many LUTs are required to implement certain combinatorial functions of a design?

IP Blocks

If an IP block, such as a BRAM or DSP block, appears repeatedly as the source or destination of your critical paths, try the following:

- Use Block Features Optimally
- Evaluate the Percentage of BRAMs or DSP Blocks
- Lock Down Block Placement
- Compare IP Blocks and Slice Logic
- Use SelectRAM™ memory
- Compare Placing Logic Functions in Slice Logic or DSP Block

Use Block Features Optimally

Verify that you are using the block features to their fullest extent. In certain FPGA architectures, these blocks contain a variety of pipeline registers that reduce the block's setup and clock-to-out times. Typically, these internal registers have synchronous sets and resets. Make sure that the Hardware Description Language (HDL) describes this behavior. Gate-level schematic viewers, such as the one available in ISE® Design Suite or Synplify Pro's HDL analyst, can be used to analyze how a synthesis tool infers an IP block and all of its features.

Evaluate the Percentage of BRAMs or DSP Blocks

Evaluate the percentage of BRAMs or DSP blocks that you are using. Both types of blocks are located in a limited number of columns dispersed throughout the FPGA fabric. This results in a more limited placement, particularly when a high percentage is used. The software can be further restricted by placement constraints for I/O or logic interfacing to those blocks.

Lock Down Block Placement

If a design is using a high percentage of BRAMs or DSP blocks which limit performance, consider locking down their placement with location constraints. For more information, see the [Constraints Guide](#).

Compare IP Blocks and Slice Logic

Consider the trade-off between using IP blocks and slice logic. Determining whether to use slice logic over IP blocks should mainly be done when an IP block is consistently showing up as the source or destination of your critical path and the features of the IP block have been used to their fullest.

Use SelectRAM Memory

If a design has a variety of memory requirements, consider using SelectRAM memory, composed of LUTs, in addition to BRAMs. Since SelectRAM is composed of LUTs, it has greater placement flexibility. In the case of DSP blocks, it could potentially be beneficial to move one of the dedicated pipeline registers to a slice register to make it easier to place logic interfacing to the DSP blocks.

Compare Placing Logic Functions in Slice Logic or DSP Block

Determine whether certain logic functions, such as adders, should be placed in the slice logic or the DSP block. Many synthesis tools can infer DSP blocks for adders and counters if the number of blocks inferred for more complex DSP functions does not exceed the number of blocks in the target device. Review the synthesis report to see where the inference of these blocks occurred.

For Synplify Pro, use the `syn_allowed_resources` attribute to control the number of blocks that the tool can infer. For more information, see the Synplify Pro documentation. If design performance is degrading due to a high percentage of DSP blocks, and it is difficult to place all the blocks with respect to their interface logic, the `syn_allowed_resources` attribute can be helpful.

Clocking Resources

You must determine whether the clocking resources of the target architecture meet design requirements. These may include:

- Number and type of clock routing resources
- Maximum allowed frequency of each of the clock routing resources
- Number of dedicated clock input pins
- Number and type of resources available for clock manipulation, such as DCMs and PLLs
- Features and restrictions of DCMs and PLLs in terms of frequency, jitter, and flexibility in the manipulation of clocks

For most Xilinx® FPGA architectures, the devices are divided into clock regions and there are restrictions on the number of clock routing resources available in each of those regions. Since the number of total clock routing resources is typically greater than the number of clocks available to a region, many designs exceed the number of clocks available for one particular region. When this occurs, the software must place the design so that the clocks can be dispersed among multiple regions. This can be done only if there are no restrictions in place that force it to place synchronous elements in a way that violates the clock region rules.

Evaluating Clocking Implementation

When evaluating how to implement the clocking for a design, analyze the following before board layout:

- What clock frequencies and phase variations must be generated for a design using either the DCM or PLL?
- Does the design use any IP blocks that require multiple clocks? If so, what types of resources are required for these blocks. How are they placed with respect to the device's clock regions?

For example, the Virtex®-4 device Tri-Mode Ethernet Macs can utilize five or more global clock resources in a clock region that allows a maximum of eight global clock resources. In these cases, Xilinx® recommends that you minimize the number of additional I/O pins you lock to the I/O bank associated with that clock region that would require different clocking resources.

- What are the total number of clocks required for your design? What is the loading for each of these clock domains? What type of clock routing resource and respective clock buffer is used?

Depending on the FPGA architecture, there can be several types of clocking resources to utilize. For example, Virtex-5 devices have I/O, regional, and global clock routing resources. It is important to understand how to balance each of these routing resources, particularly in a design with a large number of clocks, to ensure that a design does not violate the architecture's clock region rules.

- What specific I/O pins should the clocks be placed on? How can that impact BUFG/DCM/PLL placement?

For most architectures, if a clock is coming into an I/O and going directly to a BUFG, DCM, or PLL, the BUFG, DCM, or PLL must be on the same half of the device (top or bottom, left or right) of the FPGA as the I/O. DCM or PLL outputs that connect to BUFGs must have those BUFGs on the same edge of the device. Therefore, if you place all of your clock I/O on one edge of the device, you could potentially run out of resources on that edge, and be left with resources on another edge that can't use dedicated high quality routing resources due to the pin placement. Local routing may then be needed, which degrades the quality of the clock and adds unwanted routing delay.

- With the routing resources picked, IP identified, and pin location constraints taken into account, what is the distribution of clock resources into the different clock regions?

Clock Reporting

The Place and Route Report (*<design_name>.par*) includes a Clock Report that details the clocks it has detected in the design. For each clock, the report details:

- Whether the resource used was global, regional, or local
- Whether the clock buffer was locked down with a location constraint or not
- Fanout
- Maximum skew
- Maximum delay

Reviewing the Place and Route Report

Review the Place and Route Report to ensure that the proper resource was used for a particular clock, and that the net skew is appropriate. For certain architectures, such as the Spartan®-3 architecture, general interconnect, labeled as local routing in the report, can be used for clocks if carefully planned.

If the Place and Route Report shows that a clock is using a local routing resource, and it was not planned for or supported in the architecture, determine if it can be put on a dedicated clocking resource. While a clock can use a global or regional clocking resource, if it is connected to any inputs other than clock inputs, it does not use the dedicated clock routing resource, but uses general interconnect instead.

Instead of gating a clock, Xilinx® recommends using clock enables, or using the **BUFGMUX** to select between the desired clocks.

In Virtex®-4 devices and Virtex-5 devices, if a single ended clock is placed on the N-side of a global clock input differential pair, it does not have a direct route to the clock resources. A local routing resource is used instead. Using this local resource increases delay, and can degrade the quality of the clock.

Clock Region Reports

ISE® Design Suite features two reports:

- Global Clock Region Report
- Secondary Clock Region Report

These reports can help you determine:

- Which clock regions are exceeding the number of global or regional clock resources
- How many resources are being clocked by a specific clock in a clock region
- Which clock regions are not being used or are using a low number of clock resources
- How to resolve a clock region error and balance clocks over multiple clock regions.

If you run with timing driven packing and placement (**-timing**) in map, these reports appear in the map log file (`<design_name> .map`). Otherwise, these reports appear in the par report (`<design_name> .par`).

Global Clock Region Report

The Global Clock Region Report is created only if your design uses more than the maximum number of clocking resources available in a region. For example, Virtex-5 devices allow ten global clock resources in any particular clock region. Therefore, the Global Clock Region Report appears only when you have more than ten global clocks in your design.

The Global Clock Region Report details:

- The global clocks utilized in a specific region, and the associated number of resources being clocked by each clock
- Location constraints for the DCMs, PLLs, and BUFGs
- Area group constraints that lock down the loads of each specific global clock to the proper clock region

Secondary Clock Region Report

The Secondary Clock Region Report details:

- The BUFIOs, BUFRs, and regional clock spines in each clock region
- The I/O and regional clock nets that are utilized in a specific region and the associated number of resources being clocked by each clock
- Location constraints for the BUFIOs and BUFRs
- Area group constraints that lock down the loads of each specific regional clock to the proper clock region

The location constraints and the area group constraints are defined based on the initial placement at the time the report was generated. This placement could change due to the various optimizations that occur later in the flow. These constraints should be a starting point. After analyzing the distribution of the clocks into the different clock regions, adjust the constraints to ensure that the clock region rules are obeyed. After adjustments to the clocks are made, the constraints can be appended to the User Constraints File (UCF) (<design_name>.ucf) to be used for future implementation.

Defining Timing Requirements

The ISE® Design Suite synthesis and implementation tools are driven by the performance goals that you specify with your timing constraints. Your design must have properly defined constraints in order to achieve:

- Accurate optimization from synthesis
- Optimal packing, placement, and routing from implementation

Your design must include all internal clock domains, input and output (IO) paths, multicycle paths, and false paths. For more information, see the [Constraints Guide](#).

Over-Constraining

Although over-constraining can help you understand a design's potential maximum performance, use it with caution. Over-constraining can cause excessive replication in synthesis.

The auto relaxation feature in PAR automatically scales back the constraint if the software determines that the constraint is not achievable. This reduces runtime, and attempts to ensure the best performance for all constraints.

The timing constraints specified for synthesis should try to match the constraints specified for implementation. Although most synthesis tools can write out timing constraints for implementation, Xilinx® recommends that you avoid this option. Specify your implementation constraints separately in the User Constraints File (UCF) (<design_name>.ucf) For a complete description of the supported timing constraints and syntax examples, see the [Constraints Guide](#).

Constraint Coverage

In your synthesis report, check for any replicated registers, and ensure that timing constraints that might apply to the original register also cover the replicated registers for implementation. To minimize implementation runtime and memory usage, write timing constraints by grouping the maximum number of paths with the same timing requirement first before generating a specific timespec.

Examples of Non-Consolidated Constraints

```
TIMESPEC "TS_firsttimespec" = FROM "flopa" TO "flopb" 10ns;  
TIMESPEC "TS_secondtimespec" = FROM "flopq" TO "flopq" 10ns;  
TIMESPEC "TS_thirddtimespec" = FROM "flopq" TO "flopq" 10ns;
```

Consolidation of Constraints Using Grouping

```
INST "flopa" TNM = "flopqgroup";  
INST "flopq" TNM = "flopqgroup";  
INST "flopq" TNM = "flopqgroup";  
TIMESPEC "TS_consolidated" = FROM "flopqgroup" TO "flopq" 10ns;
```

Driving Synthesis

To create high-performance circuits, Xilinx® recommends that you:

- Use Proper Coding Techniques
- Analyze Inference of Logic
- Provide a Complete Picture of Your Design
- Use Optimal Software Settings

Use Proper Coding Techniques

Proper coding techniques ensure that the inferences of your behavioral Hardware Description Language (HDL) code made by the synthesis tool maximize the architectural features of the device. The Language Templates in ISE® Design Suite contain coding examples in both Verilog and VHDL.

Analyze Inference of Logic

Check to see that the design is maximizing the features of the block, and that the synthesis tool is properly inferring the expected features from your HDL code. Gate level schematic viewers, such as HDL Analyst in Synplify Pro, can help with your analysis. When using BRAMs, use the dedicated output pipeline registers when possible in order to reduce the clock-to-out delay of data leaving the RAM. The DSP blocks also have a variety of pipeline registers that reduce the setup and clock-to-out timing of these blocks.

Provide a Complete Picture of Your Design

Make sure that the synthesis tool has a complete picture of your design:

- If a design contains IP generated by the CORE Generator™ software, third party IP, or any other lower level blackboxed netlists, include those netlists in the synthesis project. Although the synthesis tool cannot optimize logic within the netlist, it can better optimize the HDL code that interfaces to these lower level netlists.
- The tool must understand the performance goals of a design using the timing constraints that you supplied. If there are critical paths in your implementation that are not seen as critical in synthesis, use the `-route` constraint from Synplify Pro to force synthesis to focus on that path.

Use Optimal Software Settings

You can modify a variety of software settings in synthesis to achieve optimal design. Xilinx recommends that you begin with a baseline set of software options, then incrementally add new switches to understand their effects. A variety of attribute settings can affect logic inference and synthesis optimization. Changing these attribute settings can affect synthesis with out having to re-code. See [Helpful Synthesis Attributes](#).

Helpful Synthesis Attributes

	Xilinx Synthesis Technology (XST)	Synplify Pro
Fanout control	MAX_FANOUT	syn_maxfan
Directs inference of RAMs to BRAMs or SelectRAM™	RAM_STYLE	syn_ramstyle
Directs usage of DSP48	USE_DSP48	syn_multstylesyn_dspstyle
Directs usage of SRL16	SHREG_EXTRACT	syn_srlstyle
Controls percent of Block RAMs utilized	N/A	syn_allowed_resources
Preservation of Register Instances During Optimizations	KEEP	syn_preserve
Preservation of wires	KEEP	syn_keep
Preservation of black boxes with unused outputs	KEEP	syn_noprune
Controls clock enable function in flip flops	USE_CLOCK_ENABLE	N/A
Controls synchronous sets	USE_SYNC_SET	N/A
Controls synchronous resets	USE_SYNC_RESET	N/A

For a complete listing of attributes and their functionality, see your synthesis tool documentation. For more information about XST constraints, see the [XST User Guide for Virtex-4, Virtex-5, Spartan-3, and Newer CPLD Devices](#).

Additional Timing Options

Although timing performance might be enhanced, options that lead to the replication of logic, such as re-timing in Synplify Pro and register balancing in Xilinx Synthesis Technology (XST), can impact area.

To reduce high fanout nets, use fanout attributes specifically on that net, instead of globally specifying a maximum fanout limit.

If hierarchical boundaries are maintained, make sure that ports are registered at the hierarchical boundaries. If critical paths cross over these hierarchical boundaries, the synthesis tool does not allow certain optimizations. Any physical synthesis options used in the implementation tools are also limited in optimizing those paths if hierarchy is maintained. This can lead both to lower performance and higher area utilization.

Another option is to set **KEEP_HIERARCHY** to **soft** in order to:

- Maintain hierarchy for synthesis
- Make it easier to perform post-synthesis simulation
- Allow the physical synthesis options of **MAP** to optimize across hierarchical boundaries

For more information about **KEEP_HIERARCHY**, see the [Constraints Guide](#).

Before you begin implementation:

- Review the warnings in your synthesis report.
- Check the RTL schematic view to see how the synthesis tool is interpreting the Hardware Description Language (HDL) code. Use the technology schematic to understand how the HDL code is mapping to the target architecture.

Choosing Implementation Options

The best options to use to achieve maximum performance may depend on the following design parameters:

- Performance goals
- Synthesis flow
- Overall structure

Performance Evaluation Mode

If you have not specified any timing constraints, use Performance Evaluation Mode to get a quick idea of design performance. ISE® Design Suite automatically generates timing constraints for each internal clock for the implementation tool only. To automatically invoke Performance Evaluation Mode, do not specify a User Constraints File (UCF). Performance Evaluation Mode enables you to obtain high performance results from the implementation tool without specifying timing goals.

Packing and Placement Option

Try the timing driven packing and placement option (**map -timing**) in **MAP** for all architectures that support it. When **map -timing** is enabled, **MAP** does both the packing and placement, while **PAR** does only the routing. By tightly integrating packing and placement, and having both processes understand the timing information, the software can take better advantage of the hardware and provide better performance.

For Virtex®-5 devices, timing driven packing and placement is the only way to run **MAP**. Because of the added complexity of the Virtex-5 device slice structure, you can achieve efficient packing only by using this strategy. For best performance, Xilinx® recommends that you run **MAP** and **PAR** with their effort levels set to **High**. While runtime is longer compared to **standard** effort level, you achieve better initial results.

Physical Synthesis Options

Physical synthesis options in implementation can re-optimize and pack logic based on knowledge of the critical paths of a design, leading to better placement and routing. The physical synthesis options are implemented during MAP. They include:

- Global netlist optimization
- Localized logic optimization
- Retiming
- Register duplication
- Equivalent register removal

For more information, see Xilinx® White Paper 230, [Physical Synthesis and Optimization with ISE®](#). These physical synthesis options provide the greatest benefit to designs that do not follow the guidelines for synthesis outlined in the previous paragraph. Physical synthesis can lead to increased area due to replication of logic.

SmartXplorer

Use ISE® Design Suite to determine which implementation options provide maximum design performance. SmartXplorer has two modes of operation:

- Timing Closure Mode
- Best Performance Mode

It is usually best to run SmartXplorer over the weekend since it typically runs more than a single iteration of **MAP** and **PAR**. Once SmartXplorer has selected the optimal tools settings, continue to use these settings for subsequent design runs. If you have made many design changes since the original SmartXplorer run, and your design is no longer meeting timing with the options determined by SmartXplorer, consider running SmartXplorer again.

Timing Closure Mode

You can access Timing Closure mode from ISE Design Suite or the command line. Timing Closure mode evaluates your timing constraints, then tries different sets of implementation options to achieve your timing goals. Although initial runtime can be longer because of the need to run multiple implementations, once you have the optimal set of options, you may reduce the number of design iterations necessary to achieve timing closure.

Best Performance Mode

In Best Performance Mode, you can focus on a particular clock domain. SmartXplorer tries to achieve the best frequency for the clock. This is especially helpful when benchmarking a design's maximum performance.

Evaluating Critical Paths

By understanding the characteristics of your critical path, you can make better decisions for the next design iteration. A data path is comprised of both logic and interconnect delay. Individual component delays that make up logic delay are fixed. Logic delay can be reduced only if the number of logic levels are reduced, or if the structure of the logic is changed. In comparison, interconnect delay is much more variable, and is dependent on the placement of the logic.

Many Logic Levels

When your design has excessive logic levels that lead to many routing interconnects:

- Evaluate using the physical synthesis options in MAP.
- Verify that the critical paths reported in implementation match those reported in synthesis. If they do not, use constraints such as *-route* from Synplify Pro to focus the synthesis tool on these paths.
- Review your Hardware Description Language (HDL) code to ensure that it is taking the best advantage of the hardware.
- Make sure inferencing is occurring properly, particularly for IP blocks.

Few Logic Levels

If there are few logic levels, but certain data paths do not meet your performance requirements:

- Evaluate fan out on routes with long delay.
- If the critical path's destination is the clock enable or synchronous set/reset input of a flop, try implementing the SR/CE logic using the sourcing LUT.

Xilinx Synthesis Technology (XST) has attributes that can be applied globally or locally to disable the inference of registers with synchronous sets or resets or clock enables. Instead they infer the synchronous set or reset or clock enable function on the data input of the flip flop. This may allow better packing of LUTs and FFs into the same slice. This can be especially useful for Virtex®-5 devices where there are four registers in each slice, and each must use the same control logic pins.

- If a critical path contains IP blocks such as Block RAMs or DSP48s, check that the design is taking full advantage of the embedded registers. Understand when to make the trade-off between using these blocks versus using slice logic.
- Do a placement analysis. If logic appears to be placed far apart from each other, floorplanning of critical blocks may be required. Try to floorplan only the logic that is required to meet the timing objectives. Over floorplanning can cause worse performance.
- Evaluate clock path skew. If the clock skew appears to be larger than expected, load the design in FPGA Editor and verify that all clock resources are routed on dedicated clocking resources. If they are not, this could lead to large clock skew.

SmartGuide Technology

Use SmartGuide™ Technology to preserve the unchanged portions of a design.

SmartGuide Technology

Feature/Function	SmartGuide Technology
Re-uses a previous implementation	Yes
Unchanged modules are guaranteed the same implementation	No
Require design planning	No
Runtime reduction	For both Placer and Router
Ease of use	Easy

When to Use SmartGuide Technology

Use SmartGuide™ Technology when:

- A design is finished and meets timing, but you are making small design changes and want to reduce runtime.
- A design is finished and meets timing, but you need to change an attribute or move a pin location.

SmartGuide Technology

SmartGuide™ Technology instructs MAP to use results from a previous implementation to guide the current one, based on a placed and routed Native Circuit Description (NCD) file. SmartGuide Technology can help achieve consistency of results while also improving runtime.

SmartGuide Technology can be enabled in:

- ISE® Design Suite
- TCL
- The command line

For more information on how to enable SmartGuide Technology , see:

- ISE Design Suite Help
- [Command Line Tools User Guide](#)

Optimal Changes for SmartGuide Technology

SmartGuide Technology is most useful for small logic changes, such as modifying a logic equation. Since large changes (such as adding new modules and instances) affect the design hierarchy, they reduce the probability of successfully matching components from a previous implementation.

The changes that work well with SmartGuide Technology are:

- A small logic change (less than 10 percent) in one or two modules
- Moving a pin location
- Changing an attribute on a component
- Changing a timing constraint

The options specified in MAP and PAR for the current implementation should match the options specified for the previous implementation used to generate the guide file. This ensures that similar algorithms and optimizations are run between both runs, ensuring the best match.

Changing both timing and placement constraints can impact the results of SmartGuide Technology . If you are changing many constraints, Xilinx® recommends that you allow the tools to run without SmartGuide Technology , then use the output of the initial run with the changed constraints as your guide file for subsequent runs.

Constraint Changes That Impact SmartGuide Technology

The following constraint changes can impact the results of SmartGuide Technology:

- Moving a pin location
Moving a pin location typically works well. Only the changed pin and net are re-routed. Difficulties may occur if the pin is moved to a congested area and requires moving nets in order to route the net that connects to the changed pin. This can cause a ripple affect in order to route the design and meet timing.
- Moving a component
Moving a component is similar to moving a pin location. Moving a component can be beneficial if it helps with timing; but it can be deleterious if the new component is moved to a congested area.
- Relaxing a timing constraint
Relaxing a timing constraint can greatly help SmartGuide Technology if a failing path now meets timing. SmartGuide Technology always tries to meet timing regardless whether the logic has changed or not. For this reason, Xilinx recommends using SmartGuide Technology only on designs that meet timing.
- Tightening a timing constraint
Xilinx does not recommend tightening a timing constraint. If the change in constraints now causes a path to fail, SmartGuide Technology re-implements that path and any other logic in order to route and meet timing

Reimplementing Without SmartGuide Technology

After about ten guided implementations, Xilinx recommends that you reimplement without using SmartGuide Technology in order to fully optimize the entire design. Reimplementing without SmartGuide Technology allows optimizations between logic that had previously been guided by SmartGuide Technology, and logic that is new or modified.

Simulating Xilinx Designs with ModelSim

This Appendix discusses Simulating Xilinx® Designs in ModelSim, and includes:

- [Simulating Xilinx Designs in ModelSim](#)
- [Simulating SecureIP with ModelSim and Questa](#)

Simulating Xilinx Designs in ModelSim

Before beginning functional simulation, you must use Complib to compile the Xilinx® Simulation Libraries for the target simulator. For more information, see the [Command Line Tools User Guide](#).

Running Simulation from ISE Design Suite (VHDL or Verilog)

ISE® Design Suite automatically creates the commands needed to run the simulation.

1. Select the **Simulation** radio button in the **View** pane, choose the simulation to run from the drop-down list.
2. Select the **Testbench** in the **Hierarchy** pane.
3. Run the **Simulate <respective> Model** process in the **Processes** pane.

Running Functional Simulation in ModelSim (Standalone)

This section includes:

- [Running Functional Simulation in ModelSim Standalone \(Verilog\)](#)
- [Running Functional Simulation in ModelSim Standalone \(VHDL\)](#)

Running Functional Simulation in ModelSim Standalone (VHDL)

To run functional simulation in ModelSim standalone (VHDL):

1. Compile the following:
 - a. source files
 - b. testbench

For example:

```
vcom -93 <source1>.vhd <source2>.vhd ... testbench.vhd
```

2. Load the design:

```
vsim -t lps work.<testbench>
```

Running Functional Simulation in ModelSim Standalone (Verilog)

To run functional simulation in ModelSim standalone (Verilog):

1. Compile the following:
 - a. `g1b1.v` module
 - b. source files
 - c. testbench

For example:

```
vlog $env(XILINX)/verilog/src/g1b1.v <source1>.v <source2>.v ... <testbench>.v
```

For more information about the `g1b1.v` module, see [Global Reset and Tristate for Simulation](#).

2. Load the design in ModelSim.
 - a. Use the `-L` switch to point to the libraries used in the design
 - b. Load the `g1b1.v` module

For example:

```
vsim -t ps -L unisims_ver -L xilinxcorelib_ver work.<testbench> work.g1b1
```

The `g1b1.v` automatically pulses Global Set/Reset (GSR) for the first 100 ns of the simulation.

Running Back Annotated Simulation in ModelSim (Standalone)

This section discusses Running Back Annotated Simulation in ModelSim (Standalone), and includes:

- [Running Back Annotated Simulation in ModelSim Standalone \(VHDL\)](#)
- [Running Back Annotated Simulation in ModelSim Standalone \(Verilog\)](#)

Running Back Annotated Simulation in ModelSim Standalone (VHDL)

To run back annotated simulation in ModelSim Standalone (VHDL):

1. Create the Simulation Model.
 - a. To create the simulation model using ISE Design Suite:

Under each stage in the **Implement Design** process, there is a **Generate Simulation Model Process**. For instance, under the Place and Route process is the **Generate Post-Place and Route Simulation Model**. This runs NetGen to generate a simulation model and an SDF file with the timing information. The default name of the model and the SDF file are `<design_name>_timesim.vhd` and `<design_name>_timesim.sdf`. Right-click the **Simulate Process** to change the properties for generating the model. Click Help for a description of each property.
 - b. To create the simulation model using the command line:

NetGen is the executable that creates simulation models. For more information, see the [Command Line Tools User Guide](#).

2. Compile the following:

- a. generated simulation model
- b. testbench

For example:

```
vcom -93 <design_name>_timesim.vhd testbench.vhd
```

3. Load the design, including the Standard Delay Format (SDF) file.

For example:

```
vsim -t ps -sdfmax /UUT=<design_name>_timesim.sdf work.testbench
```

You must supply ModelSim with the following information:

- The region where the SDF file should be applied. The region tells ModelSim where the timing simulation netlist generated by the Xilinx® tools is instantiated. Assume that the entity name in your testbench is **TESTBENCH** and the simulation netlist is instantiated inside the testbench with an instance name of **UUT**. The region for this example would be `/TESTBENCH/UUT`.
- The location of the SDF file. If the SDF file is located in the same directory as the simulation netlist, you need to supply only the name of the SDF file. Otherwise, you must specify the entire path to the SDF file.

Following is an example of the VSIM command line:

```
vsim -t ps -sdfmax /testbench/uut=c:/project/sim/time_sim.sdf work.testbench
```

Running Back Annotated Simulation in ModelSim Standalone (Verilog)

To run back annotated simulation in ModelSim Standalone (Verilog):

1. Create the Simulation Model.
 - a. To create the simulation model using ISE® Design Suite:
Under each stage in the Implement Design process, there is a Generate Simulation Model Process. For instance, under the Place and Route process is the Generate Place and Route Simulation Model. This runs NetGen to generate a simulation model and an SDF file with the timing information. The default name of the model and the SDF file are `<design_name>_timesim.v` and `<design_name>_timesim.sdf`. Right-click the Simulate Process to change the properties for generating the model. Click Help for a description of each property.
 - b. To create the simulation model using the command line:
NetGen is the executable that creates simulation models. For more information, see the [Command Line Tools User Guide](#).
2. Load the design in ModelSim.
 - a. Use the `-L` switch to point to the Verilog SIMPRIM models that define the behavior of the components in the simulation model.
 - b. Load the `g1b1` module.

For example:

```
vsim -t ps -L simprims_ver work.<testbench> work.g1b1
```

For Verilog, the timing simulation netlist has a `$sdf_annotate` statement that calls the SDF file. Therefore the SDF file is automatically pulled in when loading the simulation. The `g1b1.v` automatically pulses Global Set/Reset (GSR) for the first 100 ns of the simulation.

Simulating SecureIP with ModelSim and Questa

This section discusses Simulating SecureIP with ModelSim and Questa. For more information about SecureIP, see [Encryption Methodology Used for SecureIP Models](#).

Since SecureIP is a Verilog standard, ModelSim and Questa require a Verilog license. If you do not have a Verilog license, see [How do I run simulation with Xilinx SecureIP in ModelSim without a Verilog license? \(Xilinx Answer Record 33118\)](#).

Use Compplib to compile Xilinx® libraries (including SecureIP libraries). For more information, see the [Command Line Tools User Guide](#).

Compplib sets up the libraries automatically. The `modelsim.ini` file is edited accordingly. Once the libraries are compiled using Compplib, no additional changes needed to `modelsim.ini` are required.

The only additional switch needed to run ModelSim simulation after compiling Xilinx libraries is the `-L` switch that points to the SecureIP library.

```
vsim -t ps -L secureip -L simprims_ver work.<testbench>  
work.g1b1
```

For help with SecureIP simulation, open a WebCase with Xilinx Technical Support at <http://www.xilinx.com/support>.

Simulating Xilinx Designs in IES

This Appendix discusses Simulating Xilinx® Designs in Incisive Enterprise Simulator (IES). This Appendix includes:

- [Running Simulation from ISE® Design Suite](#)
- [Running Simulation in NC-Verilog](#)
- [Running Simulation in NC-VHDL](#)

Running Simulation from ISE Design Suite

IES is not integrated with ISE® Design Suite.

Running Simulation in NC-Verilog

This section discusses Running Simulation in NC-Verilog, and includes:

- [Running Simulations in NC-Verilog \(Method One\)](#)
- [Running Simulations in NC-Verilog \(Method Two\)](#)
- [Simulating SecureIP with NC-Verilog](#)

Running Simulations in NC-Verilog (Method One)

Running Simulations in NC-Verilog (Method One) uses library source files with compile time options (similar to Verilog-XL). Depending on the makeup of your design (for example, Xilinx® instantiated primitives, CORE Generator™ software components) for RTL simulation, specify the following at the command line:

```
irun -y $XILINX/verilog/src/unisims -y
$XILINX/verilog/src/XilinxCoreLib \
+incdir+$XILINX/verilog/src +libext+.v $XILINX/verilog/src/glbl.v \
<testfixture>.v <design>.v
```

The `$XILINX/verilog/src/unisims` area contains the Unified Library components for RTL simulation. The `$XILINX/verilog/src/simprims` area contains generic simulation primitives.

For timing simulation and post-map simulation, or for post-translate simulation, the SIMPRIM based libraries are used. Specify the following at the command line:

```
irun -y $XILINX/verilog/src/simprims $XILINX/verilog/src/glbl.v
\+libext+.v <testfixture>.v <design>.v
```

For more information about annotating Standard Delay Format (SDF) files, see [Back-Annotating Delay Values from SDF File](#).

Running Simulations in Cadence NC-Verilog (Method Two)

Method Two uses shared pre-compiled libraries. Before beginning simulation for this method, you must compile the Xilinx® Simulation Libraries for the target simulator. Xilinx provides a tool called `Compplib` for this purpose. For more information, see the [Command Line Tools User Guide](#).

Depending on the makeup of the design (for example, Xilinx instantiated primitives, CORE Generator™ software) for RTL simulation, edit the `hdl.var` and `cds.lib` to specify the library mapping as shown in the following examples.

CDS.LIB Example

```
# cds.lib DEFINE worklib worklib
```

HDL.VAR Example

```
# hdl.var DEFINE LIB_MAP ($LIB_MAP, + => worklib)
```

After setting up the libraries, compile and simulate the design:

```
ncvlog -messages -update $XILINX/verilog/src/glbl.v <testfixture>.v <design>.v
ncelab -messages <testfixture_name> glbl
ies -messages <testfixture_name>
```

The `-update` option of NCVlog enables incremental compilation.

Back-Annotating Delay Values from Standard Delay Format (SDF) File

The NC-Verilog simulator reads compiled Standard Delay Format (SDF) files only. The SDF source file is supplied as an argument in a `$sdf_annotate` task by NetGen. For more information on NetGen, see the [Command Line Tools User Guide](#).

SDF files must be with NCSDFC to annotate the timing information contained in the SDF file:

```
ncsdfc sdf_filename.sdf
```

NCSDFC creates a file called `sdf_filename.sdf.X`. If a compiled file exists, NCSDFC checks to make sure that the date of the compiled file is newer than the date of the source file and that the version of the compiled file matches the version of NCSDFC. If either check fails, the SDF file is recompiled. Otherwise, the compiled file is read.

For Back Annotated simulation, the SIMPRIM based libraries (except for Post Synthesis) are used. Specify the following at the command line:

```
ncvlog -messages -update $XILINX/verilog/src/glbl.v <testfixture>.v time_sim.v
ncelab -messages -autosdf <testfixture_name> glbl
ies -messages <testfixture_name>
```

Simulating SecureIP with NC-Verilog

This section discusses Simulating SecureIP with NC-Verilog. For more information about SecureIP, see [Encryption Methodology Used for SecureIP Models](#).

Starting with Release 11.1, all Hard IP blocks are encrypted using SecureIP. For the supported versions of IES, see [Xilinx Supported Simulators and Operating Systems](#).

Multi-Step Process with Precompiled Libraries

1. Run `Compplib` to compile Xilinx® libraries (including SecureIP libraries).
`Compplib` compiles all the libraries and updates `CDS.lib` and `HDL.var` files with the library mappings.
 For more information about `Compplib`, see the [Command Line Tools User Guide](#).
2. Run `ncvlog`, `ncelab` and `IES`.
 The simulator automatically references the SecureIP libraries based on the mappings in the `CDS.lib` and `HDL.var` files. There are no extra switches or special `ENV` settings required.

Single Step Process

In the single step process, you do not have to run `Compplib` to compile Xilinx libraries. Only one additional switch is required.

```
-f $XILINX/secureip/ies/ies_secureip_cell.list.f
```

Example

```
irun \  
design>.v testbench>.v \  
${Xilinx}/verilog/src/glbl.v \  
-f $XILINX/secureip/ies/ies_secureip_cell.list.f \ \b\  
-y ${Xilinx}/verilog/src/unisims +libext+.v \  
-y ${Xilinx}/verilog/src/simprims +libext+.v \  
+access+r+w
```

For help with SecureIP simulation, open a WebCase with Xilinx Technical Support at <http://www.xilinx.com/support>.

Running Simulation in NC-VHDL

Before beginning simulation, you must use `Compplib` to compile the Xilinx® Simulation Libraries for the target simulator. For more information, see the [Command Line Tools User Guide](#).

Depending on the makeup of the design (for example, Xilinx instantiated primitives, or the CORE Generator™ software for Register Transfer Level (RTL) simulation), edit `hdl.var` and `cds.lib` to specify the library mapping as shown in the following examples.

CDS.LIB Example

```
# cds.lib DEFINE worklib worklib
```

HDL.VAR Example

```
# hdl.var DEFINE LIB_MAP ($LIB_MAP, + => worklib)
```

Running Behavioral Simulation With NC-VHDL

After setting up the libraries, compile and simulate the design as follows:

```
ncvhdl <testbench>.vhd <design_name>.vhd ncelab -lib_binding -vhdl_time_precision lps -work worklib  
-cdslib cds.lib -access +wc worklib.testbench:behavior ies -extassertmsg -gui -cdslib cds.lib  
worklib.<testbench>:<architecture_name>
```

Running Timing Simulation With Cadence NC-VHDL

For timing simulation, you must compile the Standard Delay Format (SDF) file and then add it to the **ncelab** line.

To compile the SDF, run the command:

```
ncsdfc <name_sdf_file>
```

This command writes out a <name_sdf_file> .X file, which is a compiled SDF file. If a compiled file exists, NCSDFC checks to make sure that the date of the compiled file is newer than the date of the source file and that the version of the compiled file matches the version of NCSDFC.

In the **NC-Elab** stage, the switch **-SDF_CMD_FILE** <file_name> expects a command file for the SDF file as in the following example:

```
// SDF command file sdf_cmd1 COMPILED_SDF_FILE = "dcmt_timesim_vhd.sdf.X", SCOPE = :uut,  
MTM_CONTROL = "MAXIMUM", SCALE_FACTORS = "1.0:1.0:1.0", SCALE_TYPE = "FROM_MTM"; // END OF FILE: sdf_cmd
```

Once the SDF is annotated correctly, change **NC-Elab** to the following:

```
ncelab -vhdl_time_precision lps -work worklib -cdslib cds.lib -SDF_CMD_FILE <file_name> -access  
+wc worklib.<testbench>:<architecture_name>
```

If you are using IUS5.5 or higher, run the following command:

```
ncelab -lib_binding -vhdl_time_precision lps -work worklib -cdslib cds.lib  
-SDF_CMD_FILE <file_name> -access +wc worklib.<testbench>:<architecture_name>
```

Simulating Xilinx Designs with Synopsys VCS and VCS MX

This Appendix discusses Simulating Xilinx® Designs in Synopsys VCS and VCS MX. This Appendix includes:

- [Simulating Xilinx Designs from ISE® Design Suite in Synopsys VCS and VCS MX](#)
- [Simulating Xilinx Designs in Standalone Synopsys VCS and VCS MX](#)
- [Simulating SecureIP with VCS](#)

Simulating Xilinx® Designs from ISE Design Suite in Synopsys VCS and VCS MX

Synopsys VCS and VCS MX are not integrated with ISE® Design Suite.

Simulating Xilinx Designs in Standalone Synopsys VCS and VCS MX

This section discusses Simulating Xilinx® Designs in Standalone Synopsys VCS and VCS MX, and includes:

- [Using Library Source Files With Compile Time Options](#)
- [Using Shared Pre-Compiled Libraries](#)
- [Using Unified Usage Model \(Three-Step Process\)](#)

Using Library Source Files With Compile Time Options

Depending upon the makeup of the design (Xilinx® instantiated primitives or CORE Generator™ software components), for Register Transfer Level (RTL) simulation, specify the following at the command line:

```
vcs -y $XILINX/verilog/src/unisims -y $XILINX/verilog/src/xilinxcorelib \
+incdir+$XILINX/verilog/src +libext+.v $XILINX/verilog/src/glbl.v \
-Mupdate -R <testfixture>.v <design>.v
```

For timing simulation, the SIMPRIM based libraries are used. Specify the following at the command line:

```
vcs +compsdf -y $XILINX/verilog/src/simprims $XILINX/verilog/src/glbl.v \
+libext+.v -Mupdate -R <testfixture>.v time_sim.v
```

For information on back-annotating the Standard Delay Format (SDF) file for timing simulation, see [Using Standard Delay Format \(SDF\) with VCS](#).

The -R option automatically simulates the executable after compilation.

The **-Mupdate** option enables incremental compilation. Modules may be recompiled for one of the following reasons:

- The target of a hierarchical reference has changed.
- A compile time constant, such as a parameter, has changed.
- The ports of a module instantiated in the module have changed.
- Module inlining. For example, the merging internally in VCS of a group of module definitions into a larger module definition that leads to faster simulation. These affected modules are again recompiled. This is performed only once.

Using Shared Pre-Compiled Libraries

Before beginning functional simulation, use `Compplib` to compile the Xilinx® Simulation Libraries for the target simulator. For more information, see the [Command Line Tools User Guide](#).

Depending upon the makeup of the design (Xilinx instantiated primitives or CORE Generator™ software components), for Register Transfer Level (RTL) simulation, specify the following at the command-line:

```
vcs -Mupdate -Mlib=<compiled_dir>/unisims_ver -y $XILINX/verilog/src/unisims \
-Mlib=<compiled_dir>/xilinxcorelib_ver - +incdir+$XILINX/verilog/src \
+libext+.v $XILINX/verilog/src/glbl.v -R <testfixture>.v <design>.v
```

For timing simulation or post-**NGD2VER**, the SIMPRIM based libraries are used. Specify the following at the command-line:

```
vcs +compsdf -Mupdate -Mlib=<compiled_lib_dir>/simprims_ver \
-y $XILINX/verilog/src/simprims $XILINX/verilog/src/glbl.v +libext+.v \
-R <testfixture>.v time_sim.v
```

For information on back-annotating the Standard Delay Format (SDF) file for timing simulation, see [Using Standard Delay Format \(SDF\) with VCS](#).

The **-R** option automatically simulates the executable after compilation.

The **-Mlib=<compiled_lib_dir>** option provides VCS with a central place to look for the descriptor information before it compiles a module and a central place to obtain the object files when it links the executables together.

The **-Mupdate** option enables incremental compilation. Modules may be recompiled for one of the following reasons:

- The target of a hierarchical reference has changed.
- A compile time constant such as a parameter has changed.
- The ports of a module instantiated in the module have changed.
- Module inlining. For example, merging internally in VCS a group of module definitions into a larger module definition leads to faster simulation. These affected modules are again recompiled. This is performed only once.

Using Unified Usage Model (Three-Step Process)

The three-step process consists of the following phases:

- Analysis
- Elaboration
- Simulation

Three-Step Process Analysis Phase

The three-step process analysis phase consists of:

- `vlogan [vlogan_options] file2.v file3.v file4.v`
Analyze all Verilog files except the top-level Verilog file.
- `vhdlan [vhdlan_options] file5.vhd file6.vhd`
Analyze the VHDL bottom-most entity first, then move up in order.

Three-Step Process Elaboration Phase

The three-step process elaboration phase consists of:

```
vcs [vcs_options] entity
```

Three-Step Process Simulation Phase

The three-step process simulation phase consists of:

```
simv [simv_options]
```

For more information, see the *VCS User Guide*, located in your VCS install directory at `VCS_HOME/doc/UserGuide/vcsmx_ug_uum.pdf`.

Using Standard Delay Format (SDF) with VCS

There are two methods for back annotating delay values from an Standard Delay Format (SDF) file:

- Compiling the Standard Delay Format (SDF) file at Compile Time
- Reading the ASCII Standard Delay Format (SDF) File at Runtime

Compiling the Standard Delay Format (SDF) file at Compile Time

To compile the Standard Delay Format (SDF) file at compile time, run the `+compsdf` option as follows:

```
vcsvi -R -f options.f +compsdf
```

VCS defaults to an SDF file that has the same name as the top-level simulation netlist. To use a different SDF file, specify the SDF file name after the `+compsdf` option. No table files are required on the command line. VCS automatically determines the required capabilities.

Reading the ASCII Standard Delay Format (SDF) File at Runtime

To read the ASCII Standard Delay Format (SDF) file at runtime, you must provide a table file with the `-P` option as follows:

1. Create a PLI table file (`sdf.tab`) that maps the `$sdf_annotate` system task to the C function `sdf_annotate_call`.
2. Use the `-P` option to specify this file as follows:

```
vcs -P sdf.tab -y $XILINX/verilog/src/simprims +libext+.v  
time_sim.v
```

Following is an example of an entry in the `sdf.tab` file:

```
$sdf_annotate call=sdf_annotate_call acc+=tchk, mp, mipb:%CELL+
```

Simulating SecureIP with VCS

This section discusses Simulating SecureIP with VCS, and includes:

- [About Simulating SecureIP with VCS](#)
- [Using Library Source Files With Compile Time Options](#)
- [Using SIMPRIM-Based Libraries for Timing Simulation](#)

About Simulating SecureIP with VCS

Starting with ISE® Design Suite Release 11.1, all IP blocks are encrypted using SecureIP. For the supported versions of VCS, see [Xilinx Supported Simulators and Operating Systems](#).

For more information about SecureIP, see [Encryption Methodology Used for SecureIP Models](#).

Using Library Source Files With Compile Time Options

Depending upon the makeup of the design (Xilinx® instantiated primitives or CORE Generator™ software components), for Register Transfer Level (RTL) simulation, specify the following at the command line:

```
vcs -f $XILINX/secureip/vcs/vcs_secureip_cell.list.f \  
-y $XILINX/verilog/src/unisims -y $XILINX/verilog/src/xilinxcorelib \  
+incdir+$XILINX/verilog/src +libext+.v $XILINX/verilog/src/global.v \  
-Mupdate -R <testfixture>.v <design>.v
```

SecureIP libraries can be used at compile time by leveraging the `-f` switch in the simulator.

Using SIMPRIM-Based Libraries for Timing Simulation

The SIMPRIM based libraries are used for timing simulation. Specify the following at the command line:

```
vcs +compsdf -y $XILINX/verilog/src/simprims $XILINX/verilog/src/global.v \  
-f $XILINX/secureip/vcs/vcs_secureip_cell.list.f \  
+libext+.v -Mupdate -R <testfixture>.v time_sim.v
```

If you are using the SystemVerilog switch with SecureIP, see [Xilinx Answer Record 32821](#).

For help with SecureIP simulation, open a WebCase with Xilinx® Technical Support at <http://www.xilinx.com/support>.