

# **ISim Hardware Co-Simulation Tutorial: Processing Live Ethernet Traffic through Virtex-5 Embedded Ethernet MAC**

UG819 (v 13.2) July 28, 2011



Xilinx is disclosing this user guide, manual, release note, and/or specification (the “Documentation”) to you solely for use in the development of designs to operate with Xilinx hardware devices. You may not reproduce, distribute, republish, download, display, post, or transmit the Documentation in any form or by any means including, but not limited to, electronic, mechanical, photocopying, recording, or otherwise, without the prior written consent of Xilinx. Xilinx expressly disclaims any liability arising out of your use of the Documentation. Xilinx reserves the right, at its sole discretion, to change the Documentation without notice at any time. Xilinx assumes no obligation to correct any errors contained in the Documentation, or to advise you of any corrections or updates. Xilinx expressly disclaims any liability in connection with technical support or assistance that may be provided to you in connection with the Information.

THE DOCUMENTATION IS DISCLOSED TO YOU “AS-IS” WITH NO WARRANTY OF ANY KIND. XILINX MAKES NO OTHER WARRANTIES, WHETHER EXPRESS, IMPLIED, OR STATUTORY, REGARDING THE DOCUMENTATION, INCLUDING ANY WARRANTIES OF MERCHANTABILITY, FITNESS FOR A PARTICULAR PURPOSE, OR NONINFRINGEMENT OF THIRD-PARTY RIGHTS. IN NO EVENT WILL XILINX BE LIABLE FOR ANY CONSEQUENTIAL, INDIRECT, EXEMPLARY, SPECIAL, OR INCIDENTAL DAMAGES, INCLUDING ANY LOSS OF DATA OR LOST PROFITS, ARISING FROM YOUR USE OF THE DOCUMENTATION.

© Copyright 2002-2011 Xilinx Inc. All Rights Reserved. XILINX, the Xilinx logo, the Brand Window and other designated brands included herein are trademarks of Xilinx, Inc. All other trademarks are the property of their respective owners. The PowerPC name and logo are registered trademarks of IBM Corp., and used under license. All other trademarks are the property of their respective owners.

# Table of Contents

---

<b>Chapter 1 Introduction</b> .....	<b>5</b>
Prerequisites.....	6
Tutorial Files.....	7
<b>Chapter 2 Tutorial</b> .....	<b>9</b>
Generating a Design in CORE Generator.....	9
Creating a Test Bench.....	22
Step 1: Generating a Design in CORE Generator .....	22
Step 2: Creating a Test Bench .....	34
Step 3: Creating a Custom Constraints File.....	34
Step 4: Compiling the Design for Hardware Co-Simulation .....	37
Step 5: Running ISim Hardware Co-Simulation .....	40
<b>Appendix Additional Resources</b> .....	<b>45</b>



# Introduction

---

This tutorial describes how to use ISim hardware co-simulation to capture live Ethernet traffic through the Virtex®-5 FPGA Embedded Tri-mode Ethernet MAC and process the captured packets from your HDL test bench at run-time.

When developing an FPGA design that uses Ethernet, it is often challenging to verify the whole design including the Ethernet MAC, Multi-Gigabit Transceivers (if SGMII is used to interface between the Ethernet MAC and PHY), and Ethernet PHY. Traditionally, we either simulate the whole design in software, or run the whole design in hardware. A full software simulation approach is useful in two aspects. It offers full visibility into the design and allows the test bench or design to be changed and re-verified in a rapid manner. The challenges, however, are setting a test bench that covers the Ethernet MAC, MGT, and PHY, and achieving a reasonable simulation speed. Very often we skip various details on the simulation of MGT and PHY, or bypass them altogether. In contrast, running the design in hardware addresses these problems, but at the cost of reduced visibility into the design, and the complexity to set up and change the test bench in hardware.

ISim hardware co-simulation is a third option in your toolbox. It gives you the flexibility to run a portion of your design in hardware while simulating the rest in software. The Ethernet MAC, MGT and PHY are, for example, good candidates to put in hardware so that they are modeled exactly and simulated quickly. The test bench and the application logic such as the packet processor in your design, which are under development, should be simulated in software so you can change, verify and debug them easily and rapidly. Figure 1-1 on page 5 shows how a design for Ethernet packet processing can be partitioned to leverage the ISim hardware co-simulation features.

## Partitioning an Ethernet Design for ISim Hardware Co-Simulation

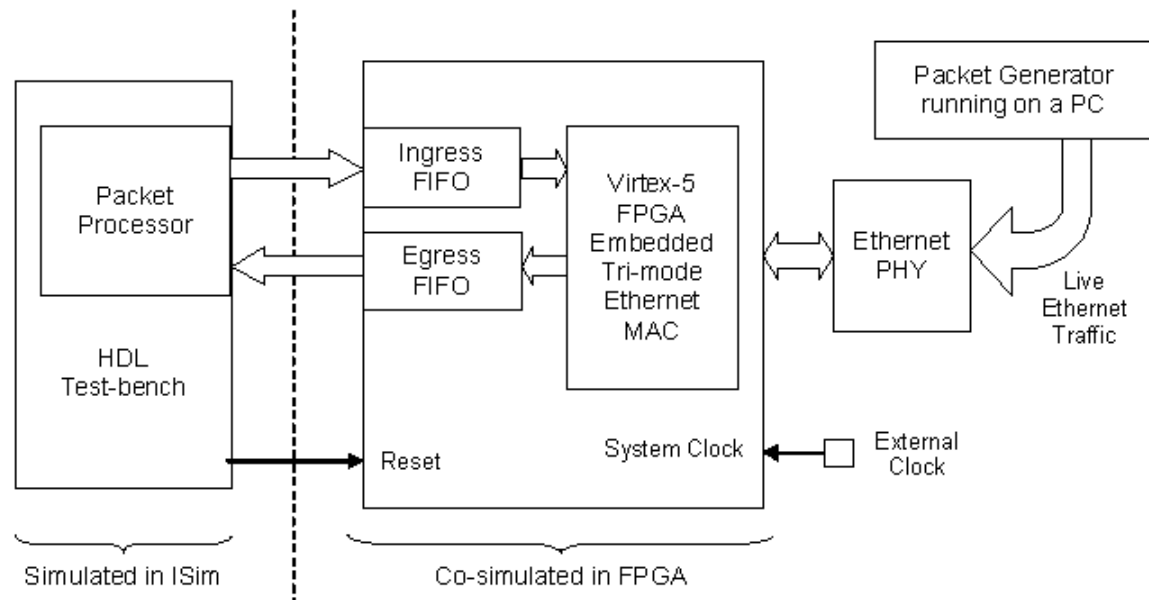

## Prerequisites

This tutorial requires the following software and hardware:

- ISE® Design Suite, version 13.2
- Virtex®-5 ML506 Evaluation Kit
- Design File: [rdf0127\\_live\\_emac\\_tutorial.zip](http://www.xilinx.com/support/documentation/tutorials/tutorials.htm#rd0127)

**Note** Please refer to the ML506 Evaluation Platform User Guide (UG347) to connect your ML506 board to your PC using a JTAG cable. In this tutorial, we use the SGMII mode to interface with the Ethernet PHY. As shown in the following figure, you need to change the jumper J22, J23 and J24 on the ML506 board to select SGMII as the default PHY interface.

### PHY Interface Mode Jumpers on ML506

SGMII to copper; no clock

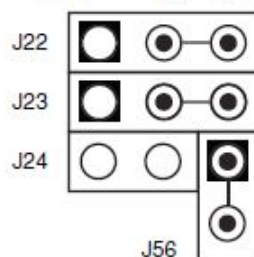

- J22: Jumper over pins 2-3
- J23: Jumper over pins 2-3
- J24: No jumper

## Tutorial Files

File	Description
v5emac_top.vhd	Wrapper that instantiates the Ethernet MAC core, ingress FIFO, egress FIFO, and packet count FIFO.
v5emac_tb.vhd	Top-level test bench that instantiates the packet processor.
simple_arp.vhd	A sample packet processor that responds to ARP requests.
v5emac_hwcosim.ucf	Custom constraints file for hardware co-simulation that indicates which ports on the v5emac_top module to be mapped to external I/Os and which ports are controlled from the test bench.
v5emac_ml50x.xise	ISE project for this tutorial.
ipcore_dir	CORE Generator™ directory that contains the Virtex®-5 Embedded Tri-mode Ethernet MAC Wrapper and FIFO cores.
init.tcl	Custom simulation command file that tells ISim to initialize the simulation.
v5emac_tb.wcfg	Custom waveform configuration file.
v5emac_tb.prj	Hardware co-simulation board support file for PEEP.
v5emac_tb.prj	Windows batch file to fully compile the design for hardware co-simulation with the Fuse command line.
full_compile.sh	Linux shell script to fully compile the design for hardware co-simulation with the Fuse command line.
incr_compile.bat	Windows batch file to incrementally compile the test bench for hardware co-simulation with the Fuse command line.
incr_compile.sh	Linux shell script to incrementally compile the test bench for hardware co-simulation with the Fuse command line.
run_isim.bat	Windows batch file to launch the ISim simulation.
run_isim.sh	Linux shell script to launch the ISim simulation.

**Note** As you work through this tutorial, you must copy all data files to your current working directory.



# Tutorial

---

This tutorial is separated into five sections that contain the steps you need to perform to run an Ethernet design through ISim hardware co-simulation. Perform the steps in the order that they are presented.

This tutorial contains the following sections:

1. Generate a Virtex®-5 Ethernet MAC example design using the Virtex-5 Embedded Tri-mode Ethernet MAC Wrapper in CORE Generator™.
2. Create a test bench to binds the Ethernet MAC wrapper to a packet processor.
3. Create a custom constraints file to specify which ports on the example design are controlled by ISim and which are mapped to external I/Os.
4. Compile the test bench for ISim simulation with the example design targeted for hardware co-simulation.
5. Connect the target FPGA board to your PC and run the ISim simulation.

## Generating a Design in CORE Generator

The Virtex-5 FPGA has an embedded tri-mode Ethernet MAC (EMAC) block, which provides a simple and reliable way to interface with an Ethernet PHY interface. The Virtex-5 Embedded Tri-mode Ethernet MAC Wrapper in CORE Generator simplifies the configuration of the Ethernet MAC block. In this tutorial, we are going to use the example design generated by the CORE Generator tool and create an ISim hardware co-simulation test bench that runs on the Virtex-5 FPGA ML506 Evaluation Kit.

**Note** The screen captures in this tutorial are based on the Virtex-5 Embedded Tri-mode Ethernet MAC Wrapper version 1.8. The CORE Generator GUI may look different in later versions of the tool.

1. Launch the ISE® Project Navigator.
2. Choose **File > New Project** to open the New Project Wizard. Enter a project name (v5emac\_ml50x) and location. Click **Next**.

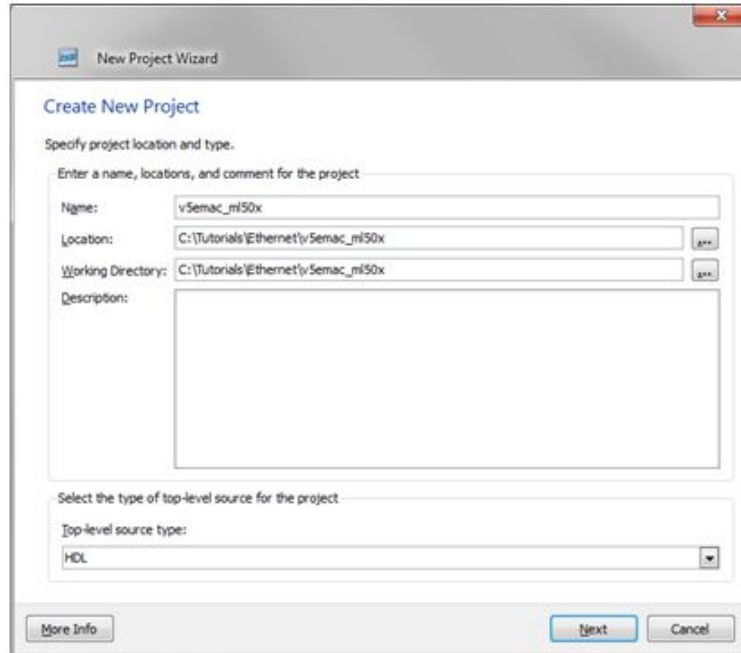

3. On the Project Settings page, choose the part for the ML605 board, which is Virtex-5 device XC5VSX50T, package FF1136, and speed -1. Select ISim as the simulator and VHDL as the preferred language. Click **Next** and then **Finish** to complete the project creation.

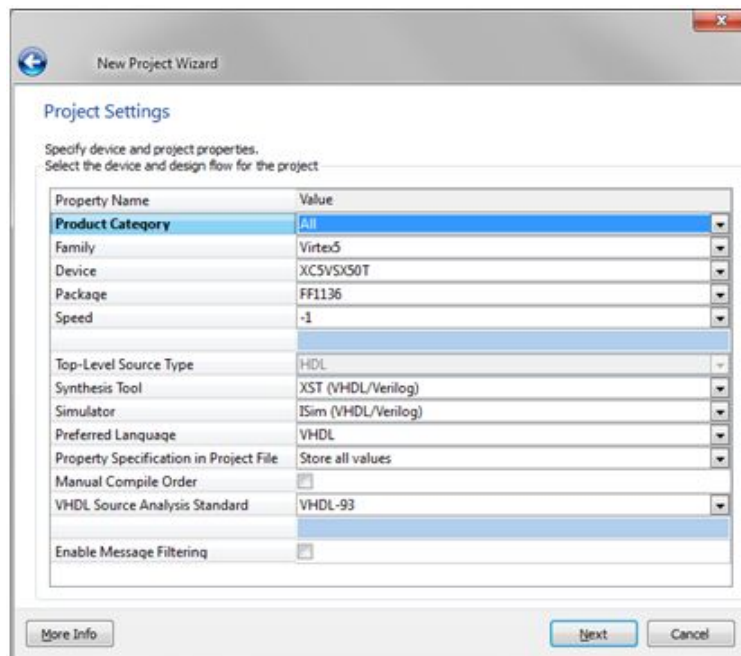

4. Choose **Project > New Source** to open the New Source Wizard. Select **IP (CORE Generator & Architecture Wizard)** and name the IP **v5emac**. Click **Next**.

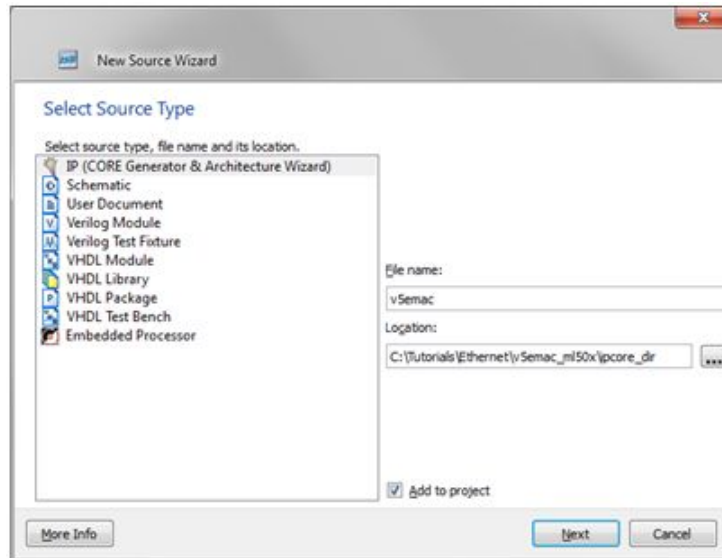

5. Select **Virtex-5 Embedded Tri-mode Ethernet MAC Wrapper version 1.8** or later from the IP list. Click **Next** and then **Finish**.

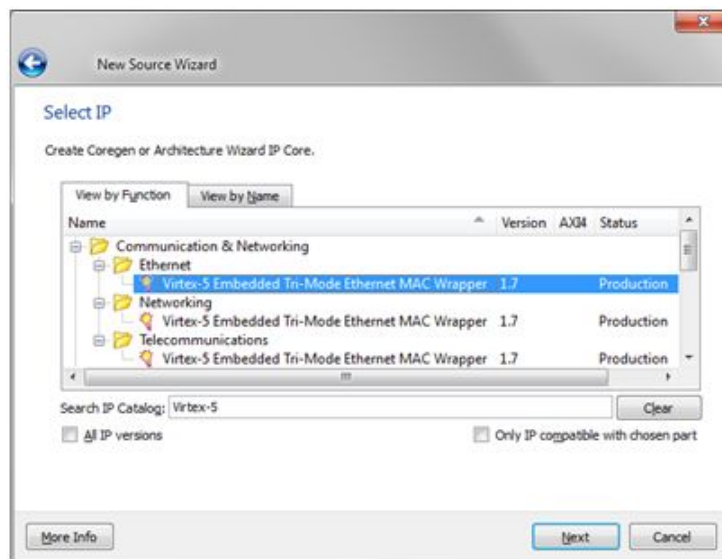

6. When the Virtex-5 Embedded Tri-Mode Ethernet MAC Wrapper dialog box opens, set the **Host Type** to **None**. Make sure **Enable EMAC 0** is checked and **Enable EMAC 1** is unchecked. Click **Next**.

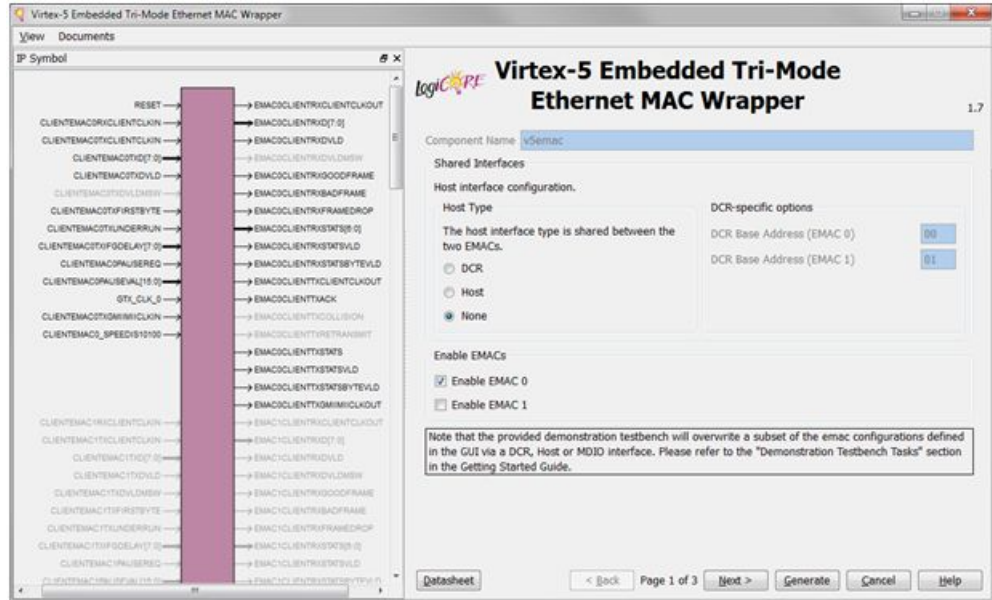

7. Set **Phy Interface** to **SGMII**, and the **Speed** to **1000 Mbps**. Leave the **MDIO** check box unchecked. Click **Next**.

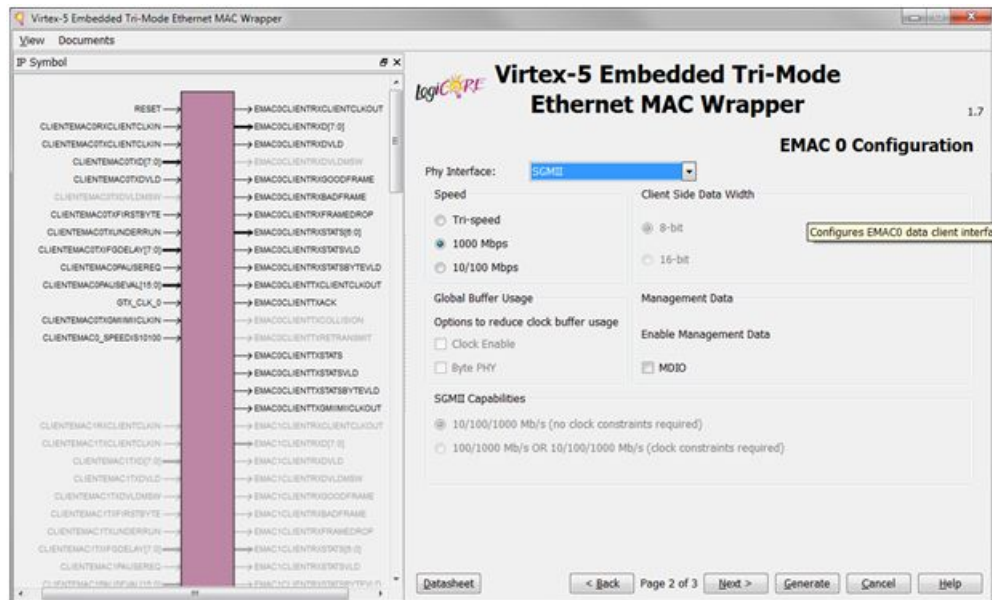

8. Use the default settings for the flow control, transmitter, receiver, and address filter configuration. Click **Generate** to generate the core.

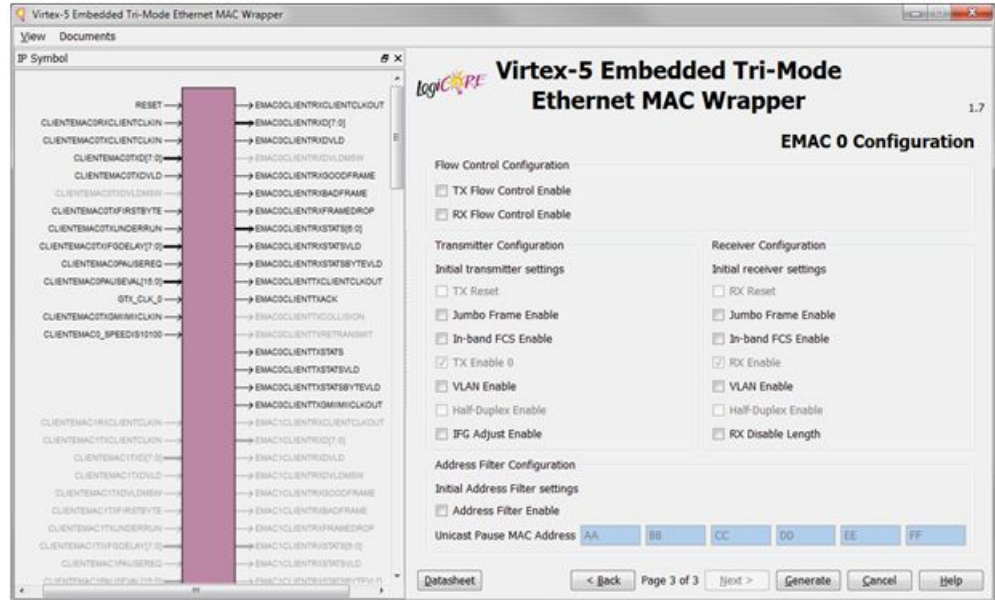

**Note** After the Ethernet MAC wrapper core is generated, we use the LocalLink submodule `v5emac_locallink` in example design generated in the `ipcore_dir/v5emac/example_design` directory.

In this tutorial, we do not use the entire example design `v5emac_example_design`, since we need to partition the design into two asynchronous halves, one simulated in lock-step with the ISim test bench and the other free-running on FPGA through hardware co-simulation. The packet processing module is simulated in ISim to achieve a full debug visibility and faster turnaround for modifications. The Ethernet MAC and MGT are free-running on FPGA to interface with the external Ethernet PHY chip on the ML506 board. This allows the Ethernet MAC to receive and transmit Ethernet packets on a live Ethernet connection.

9. Choose **Project > Add Source**. Go to the `ipcore_dir/v5emac/example_design` directory. Add the following HDL files to the ISE project (all HDL files in the example design except `v5_emac_example_design.vhd`, which is not used in this tutorial):

```
v5emac.vhd
v5emac_block.vhd
v5emac_locallink.vhd
client/address_swap_module_8.vhd
client/fifo/eth_fifo_8.vhd
client/fifo/rx_client_fifo_8.vhd
client/fifo/tx_client_fifo_8.vhd
physical/gtp_dual_1000X.vhd
physical/rocketio_wrapper_gtp.vhd
physical/rocketio_wrapper_gtp_tile.vhd
physical/rx_elastic_buffer.vhd
```

Typically, we can partition the design across the LocalLink interface where the LocalLink FIFOs serves as asynchronous buffers for crossing clock domains. However, the LocalLink FIFOs in the example design is not large enough and does not work well with the emulated clock generated by ISim. Thus, we complement the LocalLink FIFOs with a pair of asynchronous FIFOs for buffering ingress and egress packets.

10. Choose **Project > New Source** to open the New Source Wizard. Select **IP (CORE Generator & Architecture Wizard)** and name the IP `packet_fifo`. Click Next.

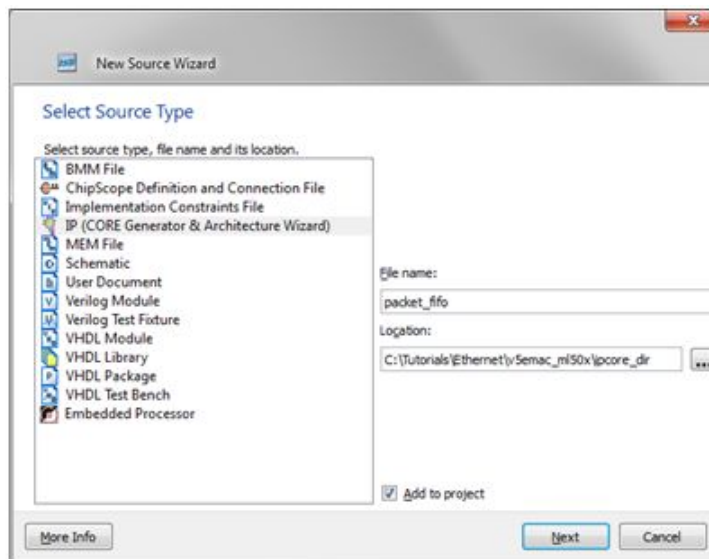

11. Select **Fifo Generator version 6.2** from the IP list. Click **Next** and then **Finish**.

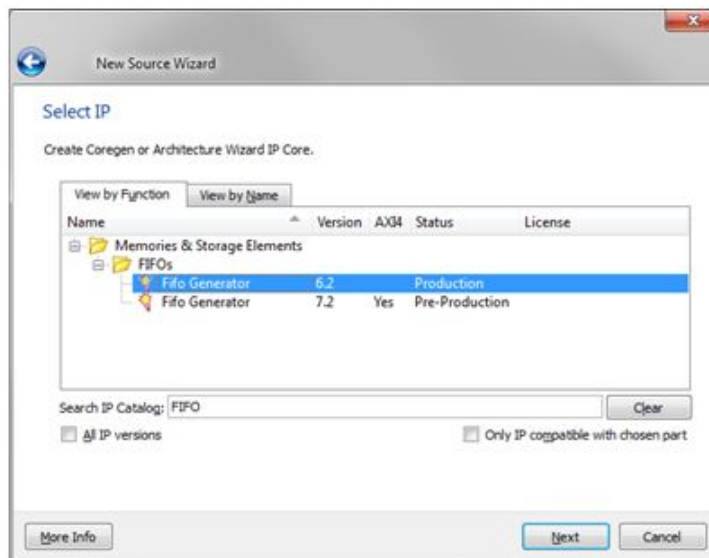

12. When the Fifo Generator core GUI opens, set the FIFO implementation to **Independent Clocks (RD\_CLK, WR\_CLK) Block RAM**. Click **Next**.

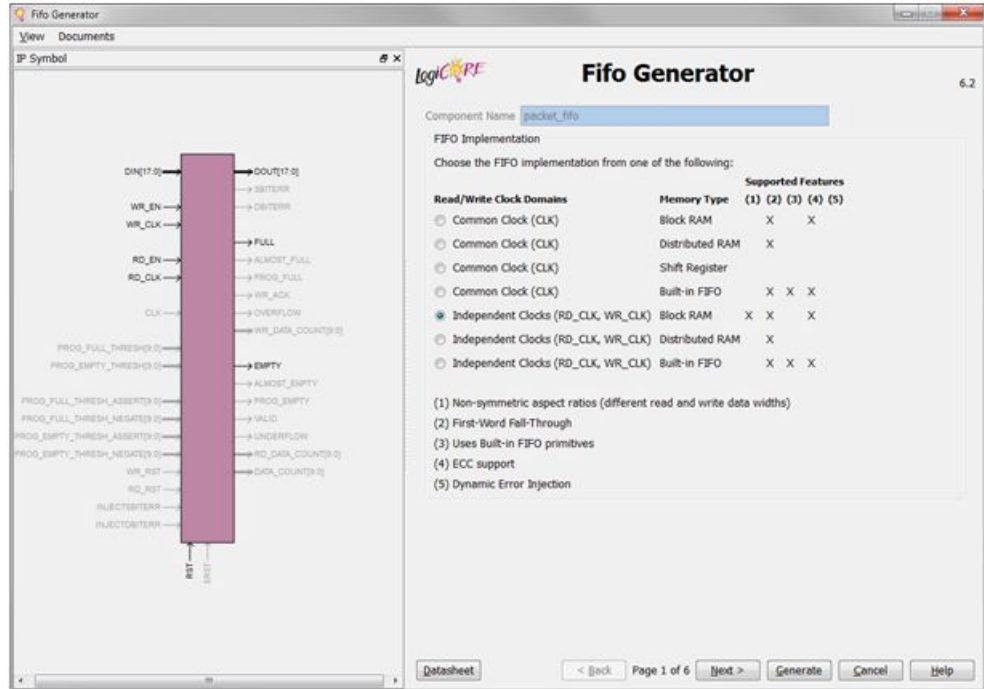

- Set the Read Mode to **First-Word Fall-Through**. Set the **Write Width** and **Read Width** to 10, and **Write Depth** to 16384. Click **Next**.

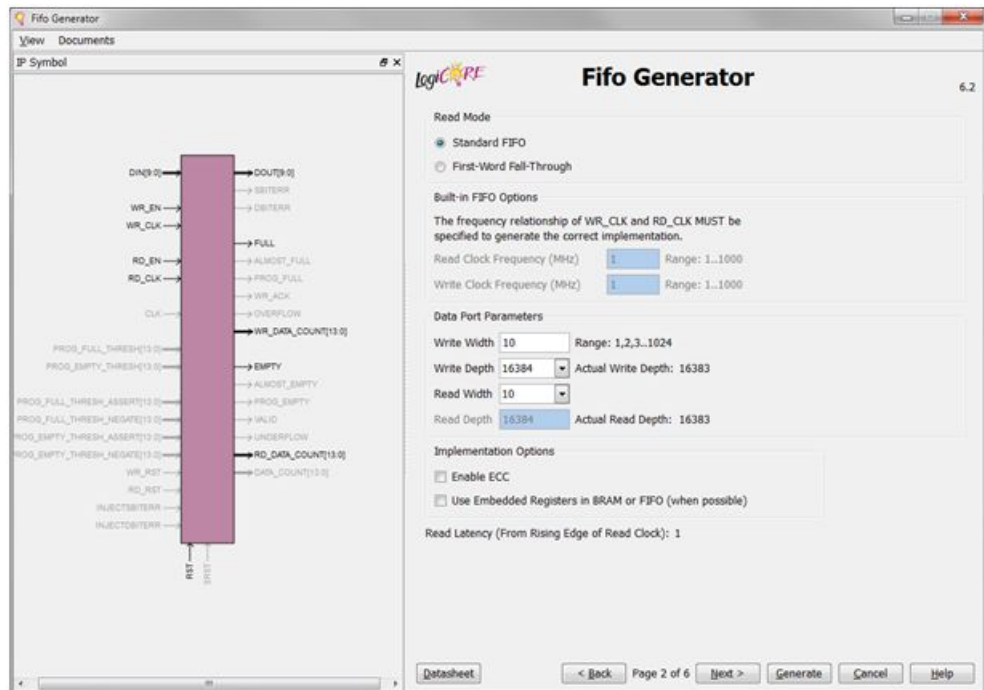

- Use the default settings for **Optional Flags**, **Handshaking Options** and **Error Injection**. Click **Next**.

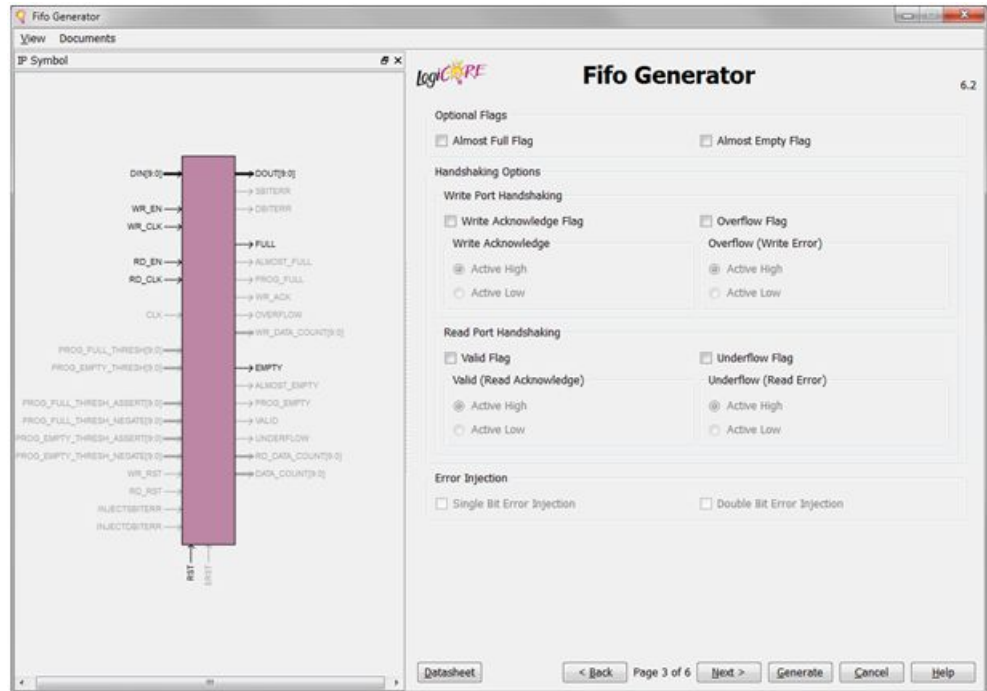

15. Use the default settings for **Initialization and Programmable Flags**. Click **Next**.

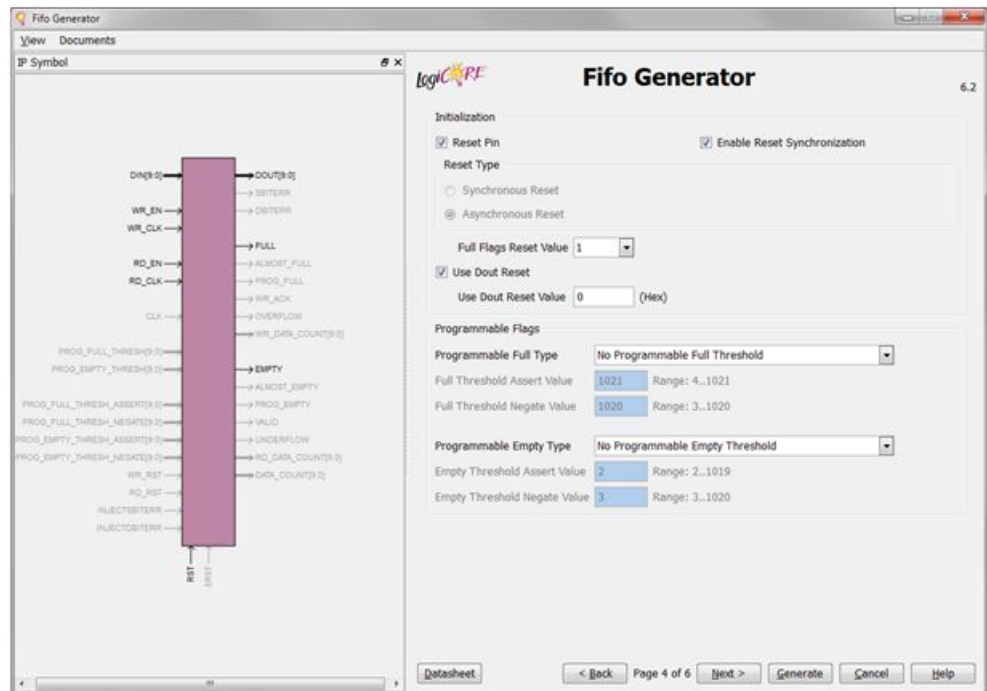

16. Set the **Write Data Count** and **Read Data Count** to **14**. Click **Next**.

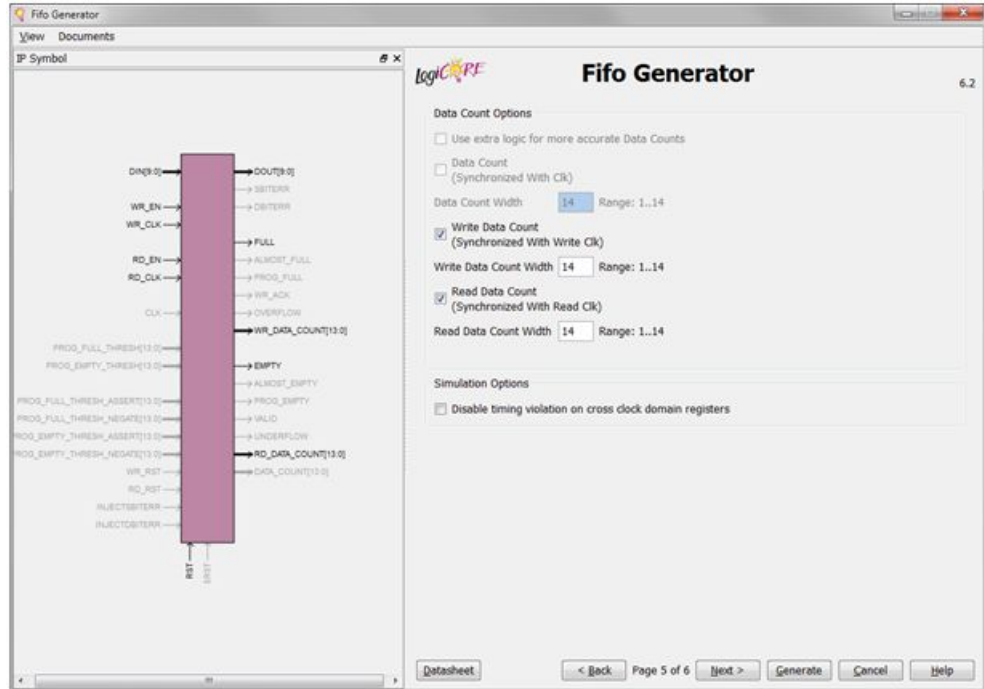

17. Click **Generate** to generate the FIFO core.

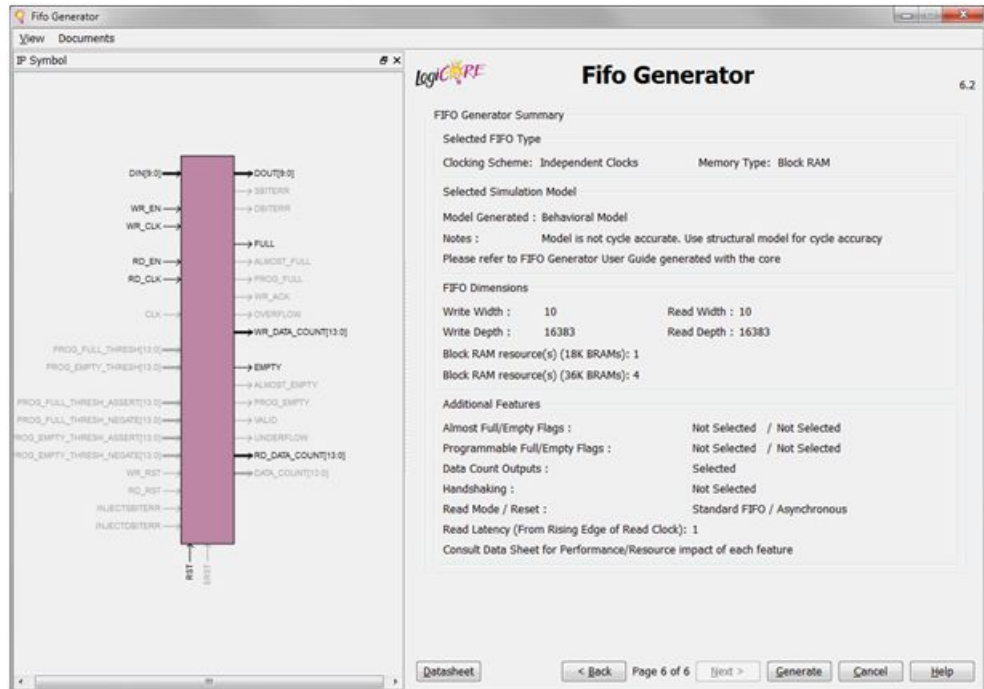

**Note** In this tutorial, the egress FIFO forwards a packet to the TX LocalLink FIFO only when there is at least one complete packet in the egress FIFO. For this purpose, we add another FIFO to monitor the packet count in the egress FIFO.

18. Choose **Project > New Source** to open the New Source Wizard. Select **IP (CORE Generator & Architecture Wizard)** and name the IP `count_fifo`. Click **Next**.

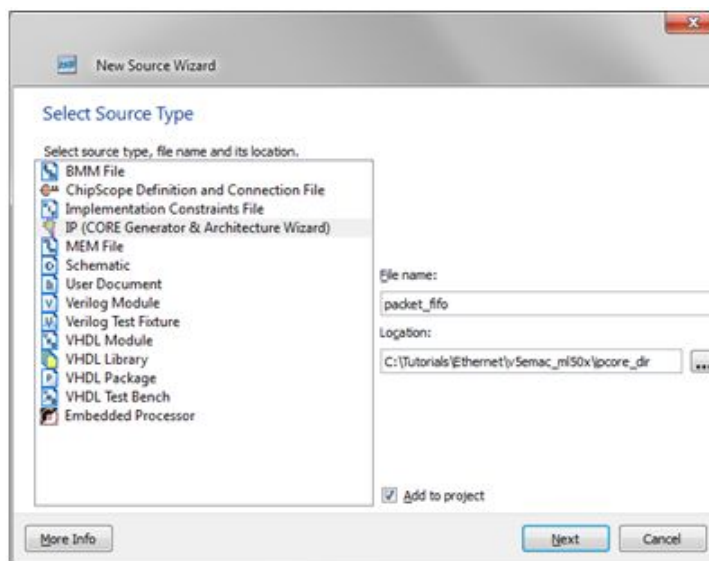

19. Select **Fifo Generator version 6.2** from the IP list. Click **Next** and then **Finish**.

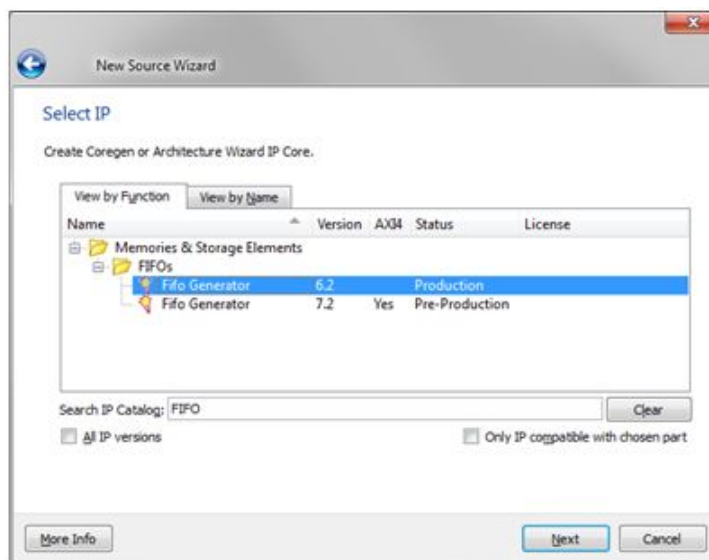

20. When the Fifo Generator core GUI opens, set the **FIFO implementation to Independent Clocks (RD\_CLK, WR\_CLK) Distributed RAM**. Click **Next**.

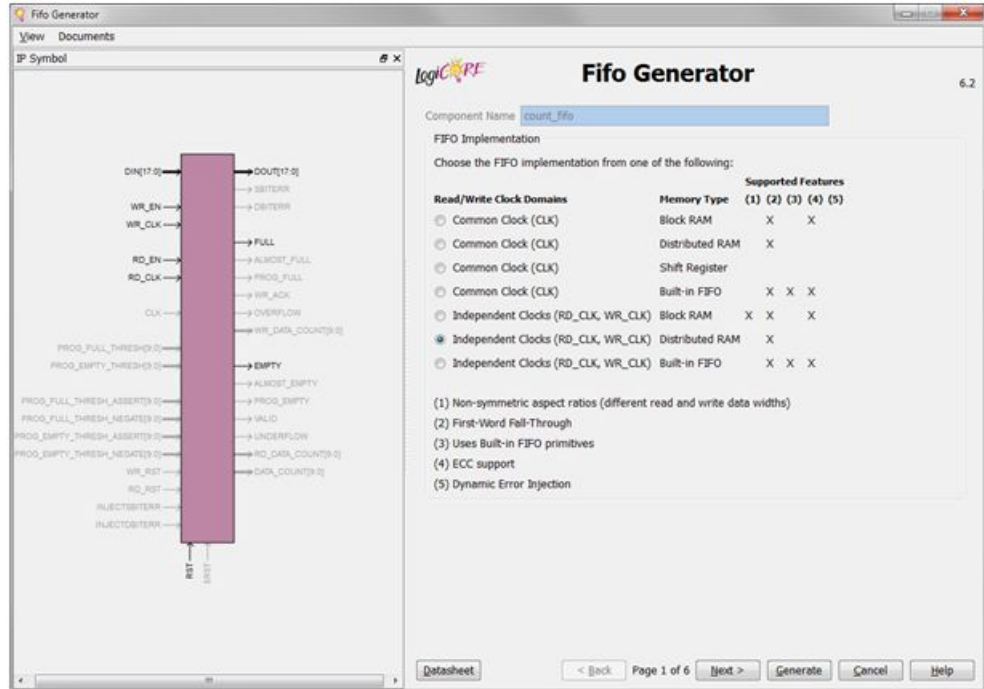

21. Set the Read Mode to First-Word Fall-Through. Set the Write Width and Read Width to 1, and Write Depth to 32. Click Next.

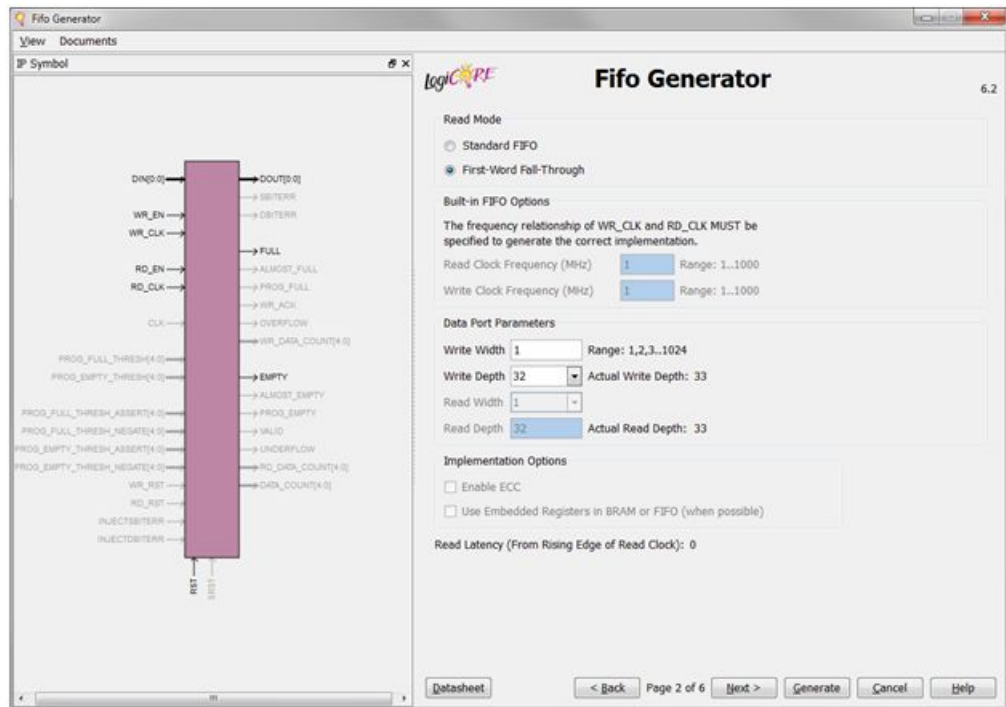

22. Use the default settings for Optional Flags, Handshaking Options and Error Injection. Click Next.

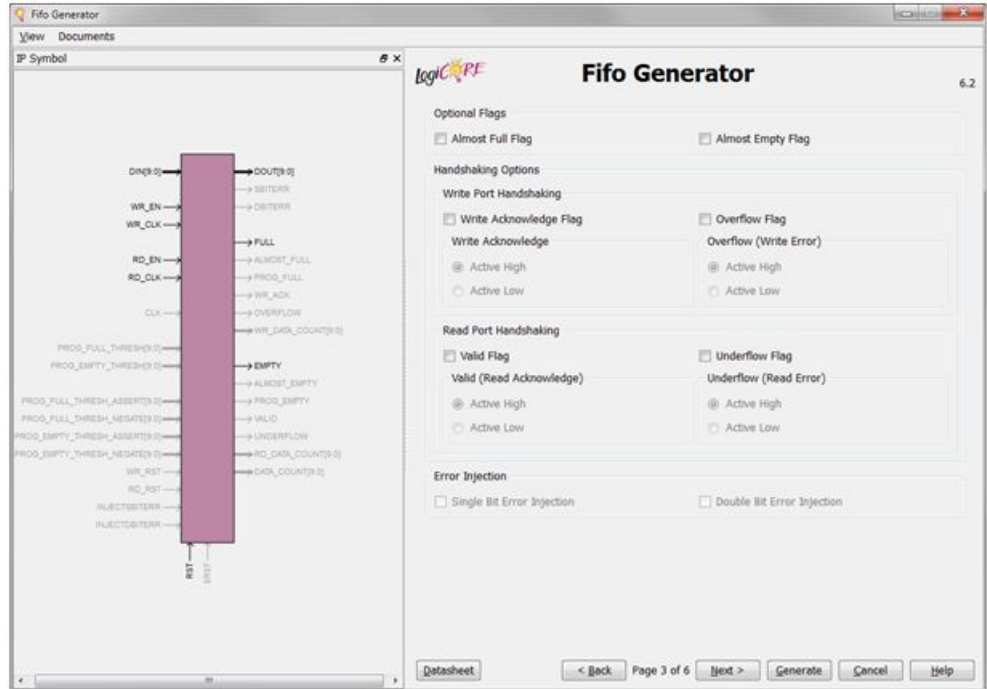

23. Use the default settings for **Initialization and Programmable Flags**. Click **Next**.

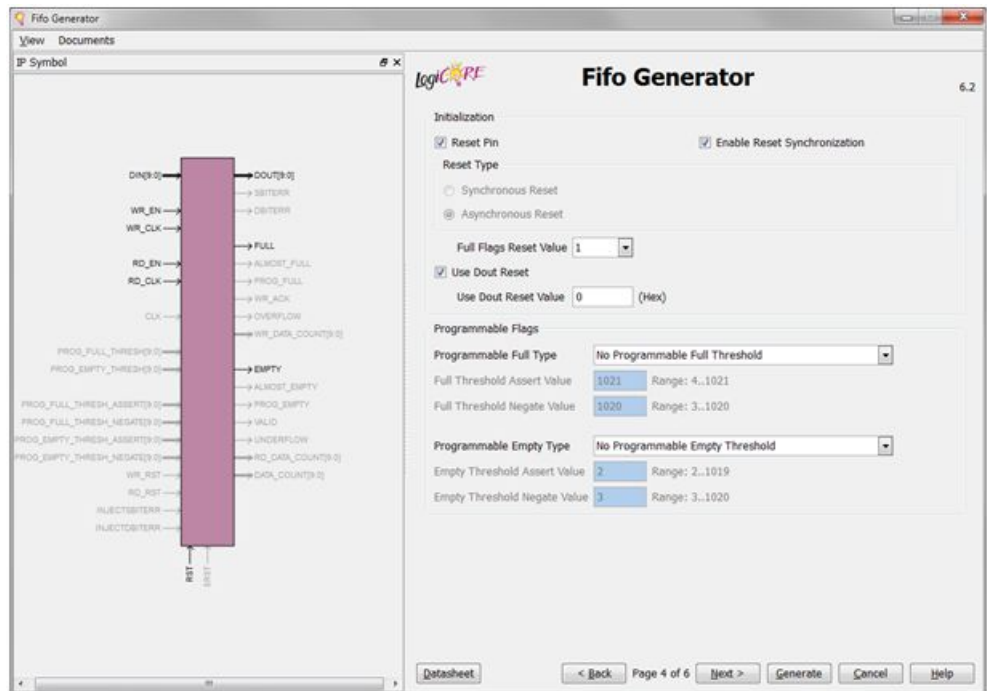

24. Set the **Write Data Count** and **Read Data Count** to **14**. Click **Next**.

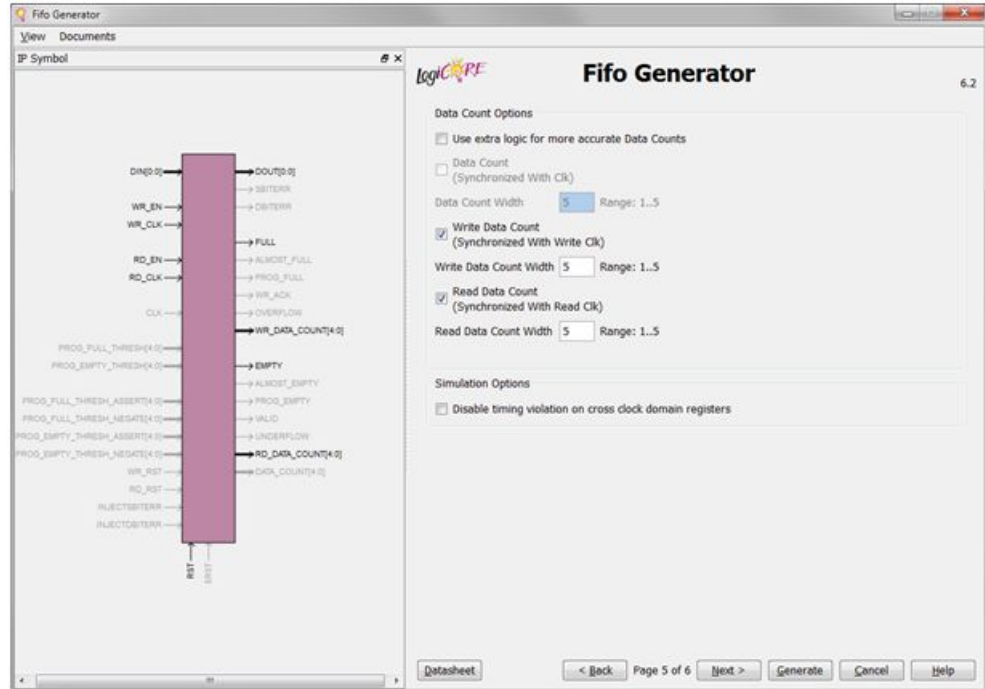

25. Click **Generate** to generate the FIFO core.

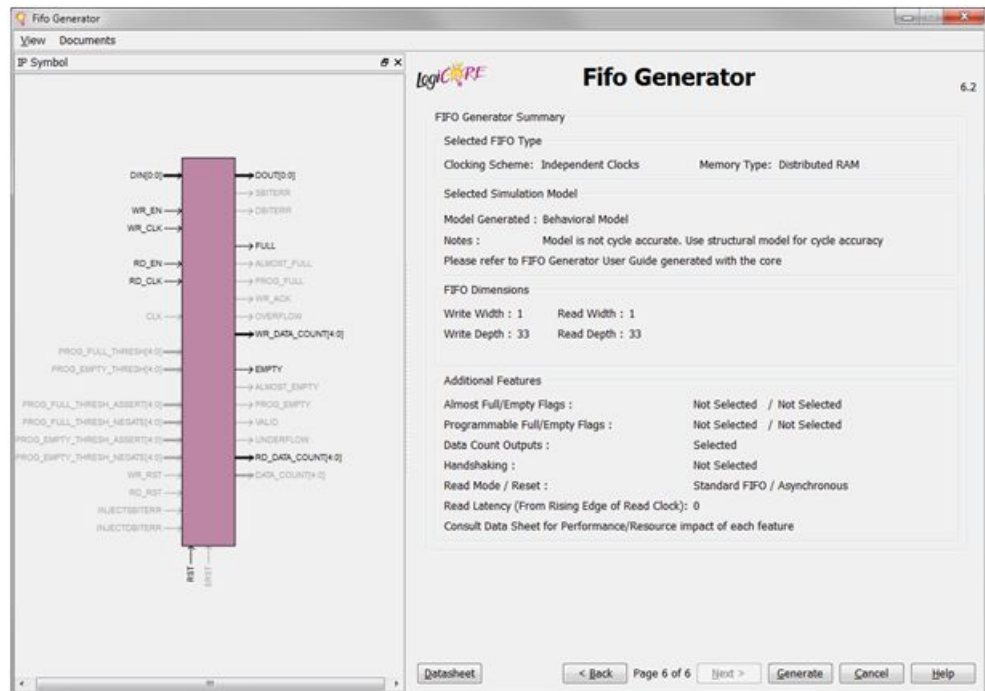

26. Add a top-level module `v5emac_top` that instantiates the `v5_emac_loclink` module, ingress FIFO, egress FIFO, and egress packet count FIFO. You can use the completed `v5emac_top.vhd` provided in this tutorial. Choose **Project > Add Source**. Add the `v5emac_top.vhd`.

## Creating a Test Bench

1. Add a VHDL test bench module `v5emac_tb.vhd` that binds the `v5emac_top` instance to a packet processor. You can use the completed `v5emac_tb.vhd` file provided in this tutorial. Select **Project > Add Source**. Add the `v5emac_tb.vhd` and `simple_arp.vhd`.

## Step 1: Generating a Design in CORE Generator

The Virtex-5 FPGA has an embedded tri-mode Ethernet MAC (EMAC) block, which provides a simple and reliable way to interface with an Ethernet PHY interface. The Virtex-5 Embedded Tri-mode Ethernet MAC Wrapper in CORE Generator simplifies the configuration of the Ethernet MAC block. In this tutorial, we are going to use the example design generated by the CORE Generator tool and create an ISim hardware co-simulation test bench that runs on the Virtex-5 FPGA ML506 Evaluation Kit.

**Note** The figures in this tutorial are based on the Virtex-5 Embedded Tri-mode Ethernet MAC Wrapper version 1.8. The CORE Generator interface may look different in later versions of the tool.

1. Launch ISE® Project Navigator.
2. **File > New Project** to open the New Project Wizard. Enter a project name (**v5emac\_ml50x**) and location. Click **Next**.

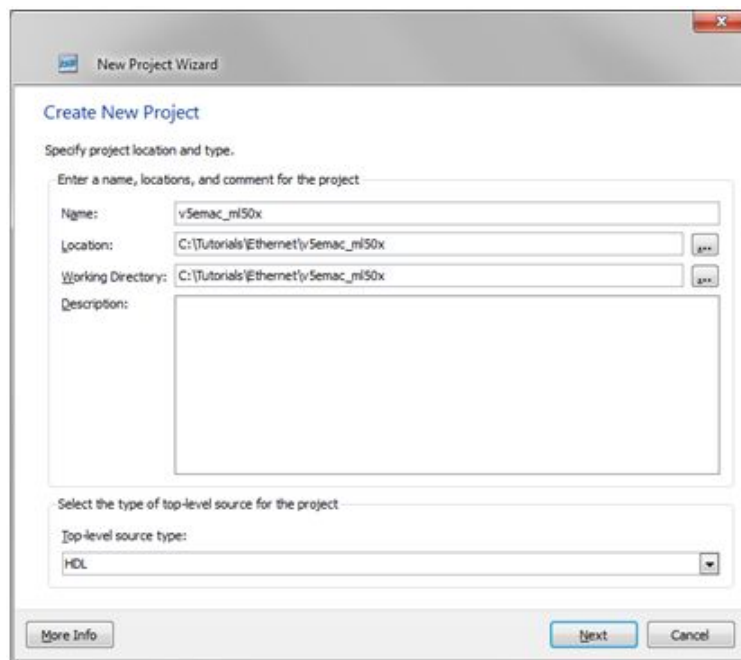

3. On the Project Settings page, choose the part for the ML605 board, which is Virtex-5 device **XC5VSX50T**, package **FF1136**, and speed **-1**. Select **ISim** as the simulator and **VHDL** as the preferred language. Click **Next** and then **Finish** to complete the project creation.

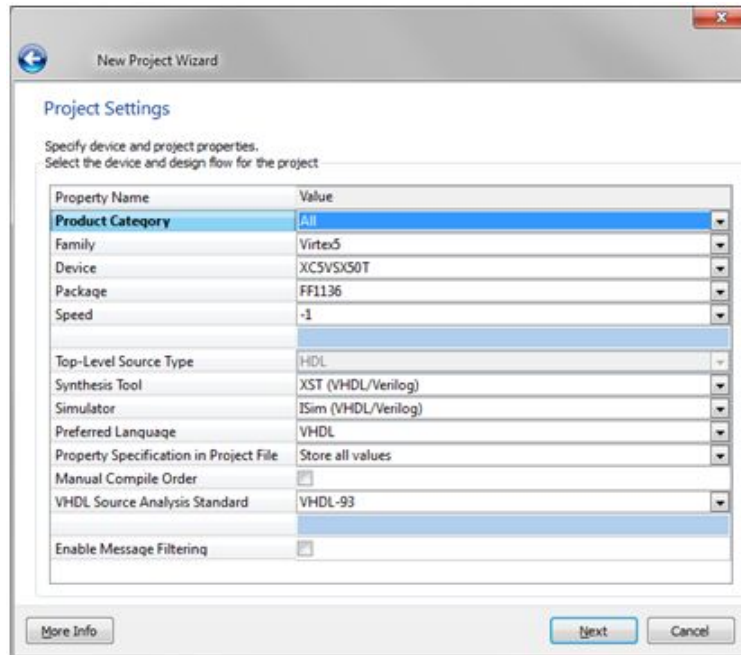

4. Choose **Project > New Source** to open the New Source Wizard. Select **IP (CORE Generator & Architecture Wizard)** and name the IP `v5emac`. Click **Next**.

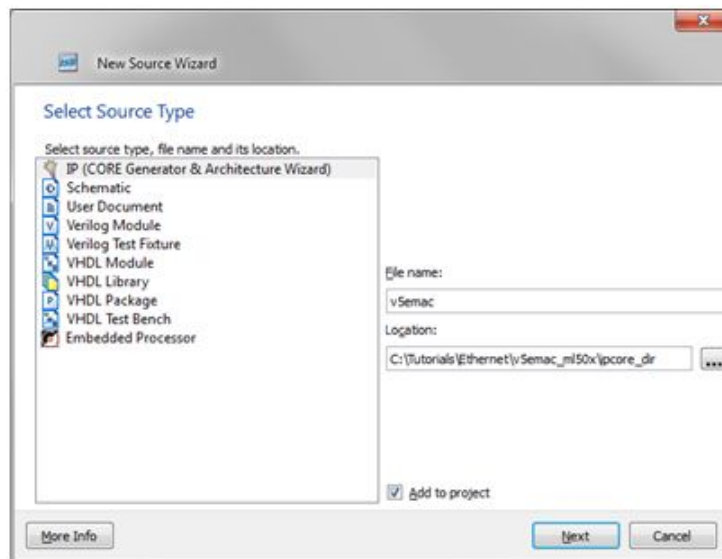

5. Select **Virtex-5 Embedded Tri-mode Ethernet MAC Wrapper version 1.8** or later from the IP list. Click **Next** and then **Finish**.

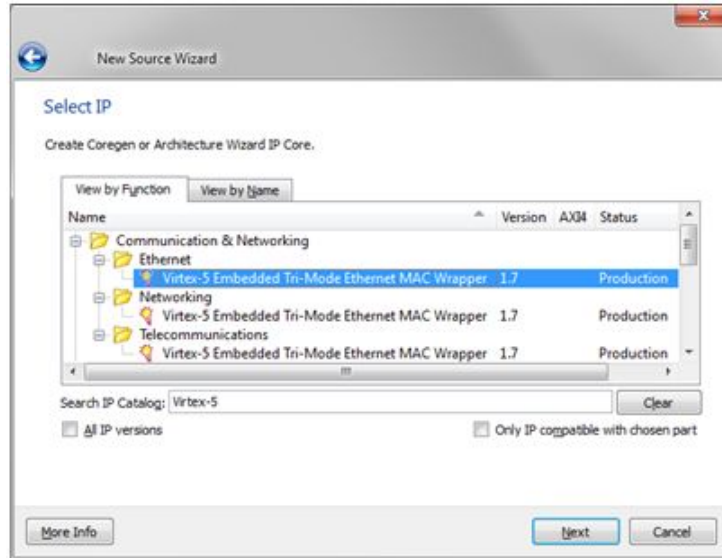

- When the Virtex-5 Embedded Tri-Mode Ethernet MAC Wrapper dialog box opens, set the **Host Type** to **None**. Make sure **Enable EMAC 0** is checked and **Enable EMAC 1** is unchecked. Click **Next**.

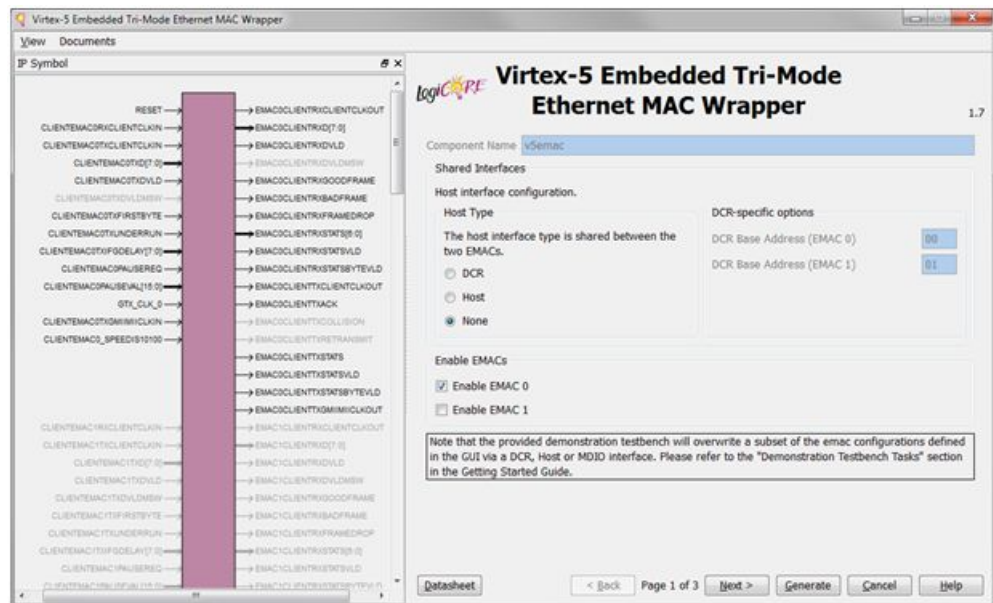

- Set **Phy Interface** to **SGMII**, and the **Speed** to **1000 Mbps**. Leave the **MDIO** check box unchecked. Click **Next**.

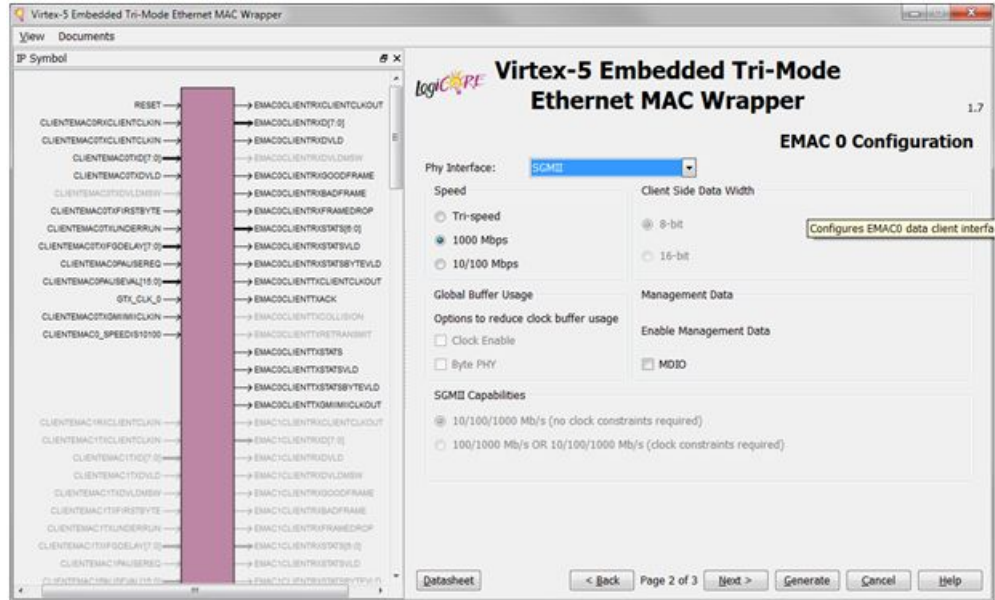

- Use the default settings for the flow control, transmitter, receiver, and address filter configuration. Click **Generate** to generate the core.

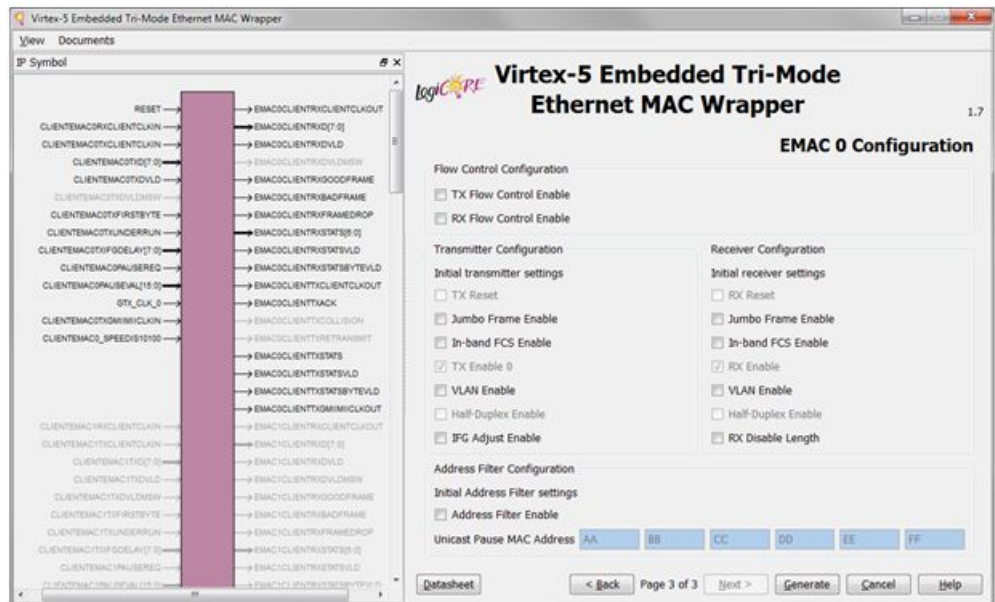

**Note** After the Ethernet MAC wrapper core is generated, we use the LocalLink submodule `v5emac_locallink` in example design generated in the `ipcore_dir/v5emac/example_design` directory.

In this tutorial, we do not use the entire example design `v5emac_example_design`, since we need to partition the design into two asynchronous halves, one simulated in lock-step with the ISim test bench and the other free-running on FPGA through hardware co-simulation. The packet processing module is simulated in ISim to achieve a full debug visibility and faster turnaround for modifications. The Ethernet MAC and MGT are free-running on FPGA to interface with the external Ethernet PHY chip on the ML506 board. This allows the Ethernet MAC to receive and transmit Ethernet packets on a live Ethernet connection.

- Choose **Project > Add Source**. Go to the `ipcore_dir/v5emac/example_design` directory. Add the following HDL files to the ISE project (all HDL files in the

example design except `v5_emac_example_design.vhd`, which is not used in this tutorial):

```
v5emac.vhd
v5emac_block.vhd
v5emac_loccallink.vhd
client/address_swap_module_8.vhd
client/fifo/eth_fifo_8.vhd
client/fifo/rx_client_fifo_8.vhd
client/fifo/tx_client_fifo_8.vhd
physical/gtp_dual_1000X.vhd
physical/rocketio_wrapper_gtp.vhd
physical/rocketio_wrapper_gtp_tile.vhd
physical/rx_elastic_buffer.vhd
```

Typically, we can partition the design across the LocalLink interface where the LocalLink FIFOs serves as asynchronous buffers for crossing clock domains. However, the LocalLink FIFOs in the example design is not large enough and does not work well with the emulated clock generated by ISim. Therefore, we complement the LocalLink FIFOs with a pair of asynchronous FIFOs for buffering ingress and egress packets.

10. Choose **Project > New Source** to open the New Source Wizard. Select **IP (CORE Generator & Architecture Wizard)** and name the IP `packet_fifo`. Click **Next**.

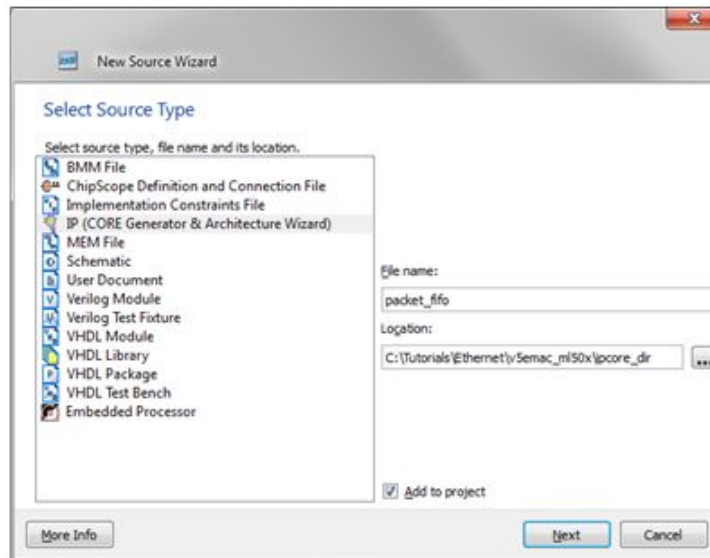

11. Select **Fifo Generator version 8.1** from the IP list. Click **Next** and then **Finish**.

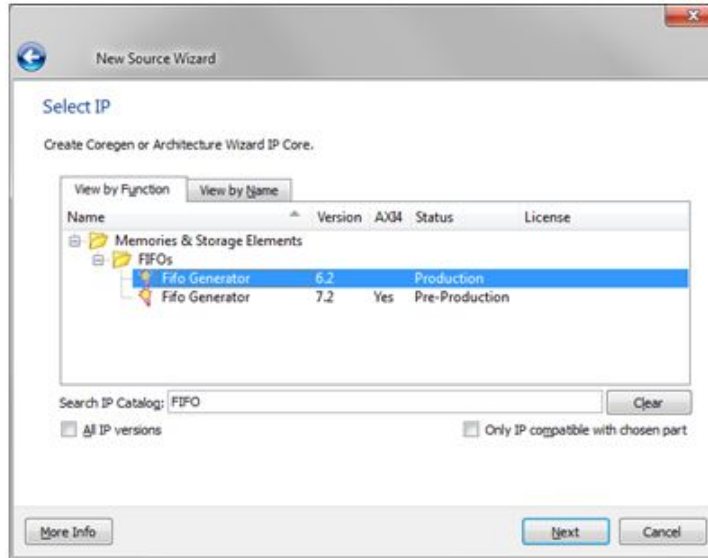

- When the Fifo Generator core GUI opens, set the FIFO implementation to **Independent Clocks (RD\_CLK, WR\_CLK) Block RAM**. Click Next.

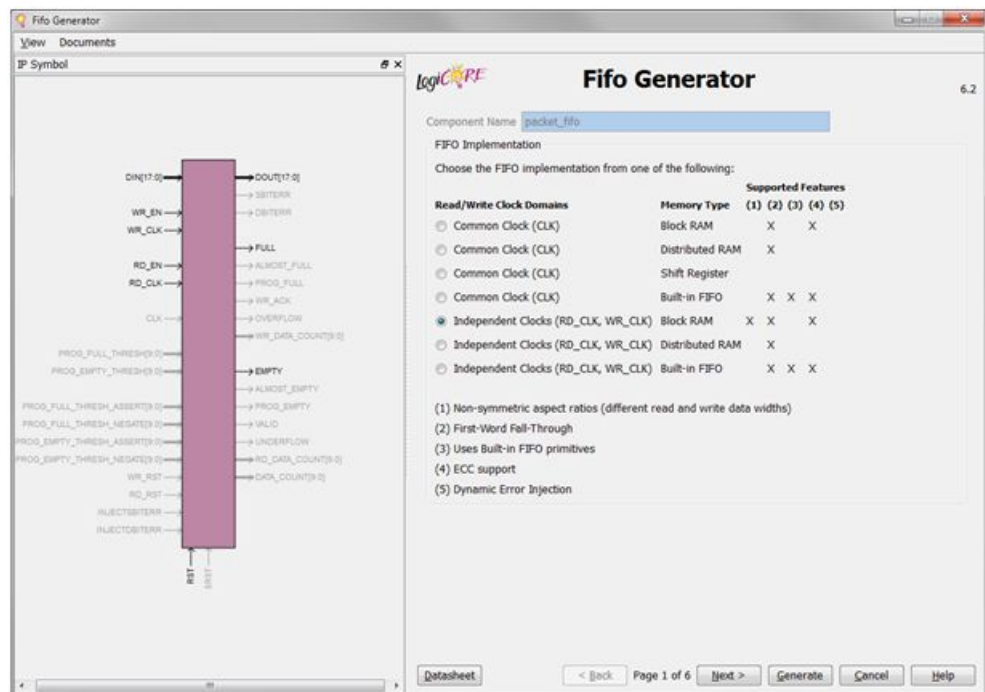

- Set the Read Mode to **First-Word Fall-Through**. Set the **Write Width** and **Read Width** to 10, and **Write Depth** to 16384. Click Next.

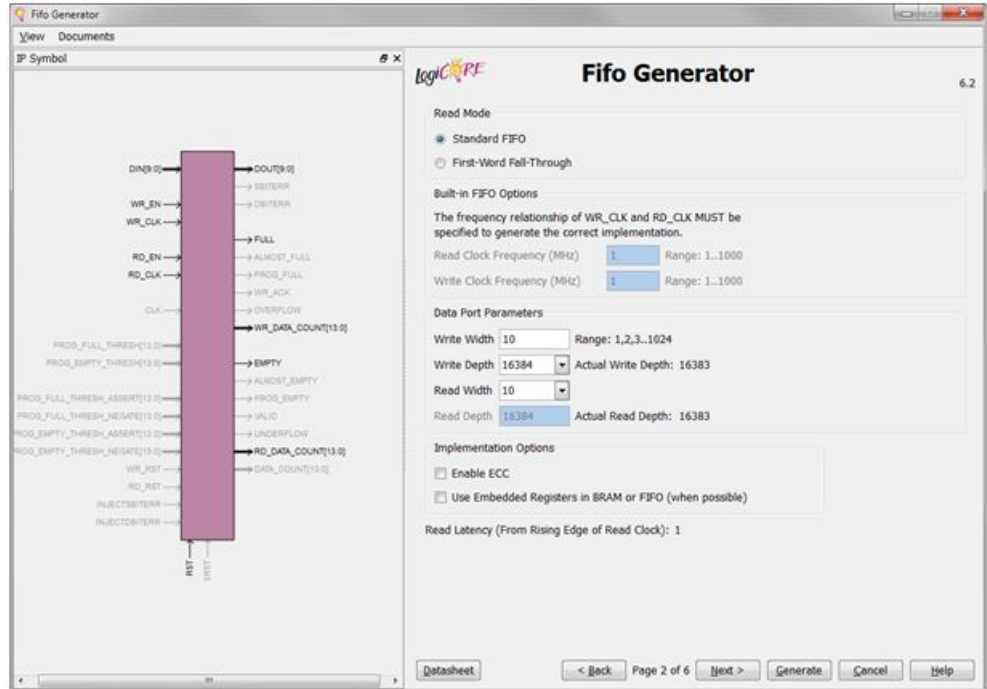

14. Use the default settings for **Optional Flags, Handshaking Options and Error Injection**. Click **Next**.

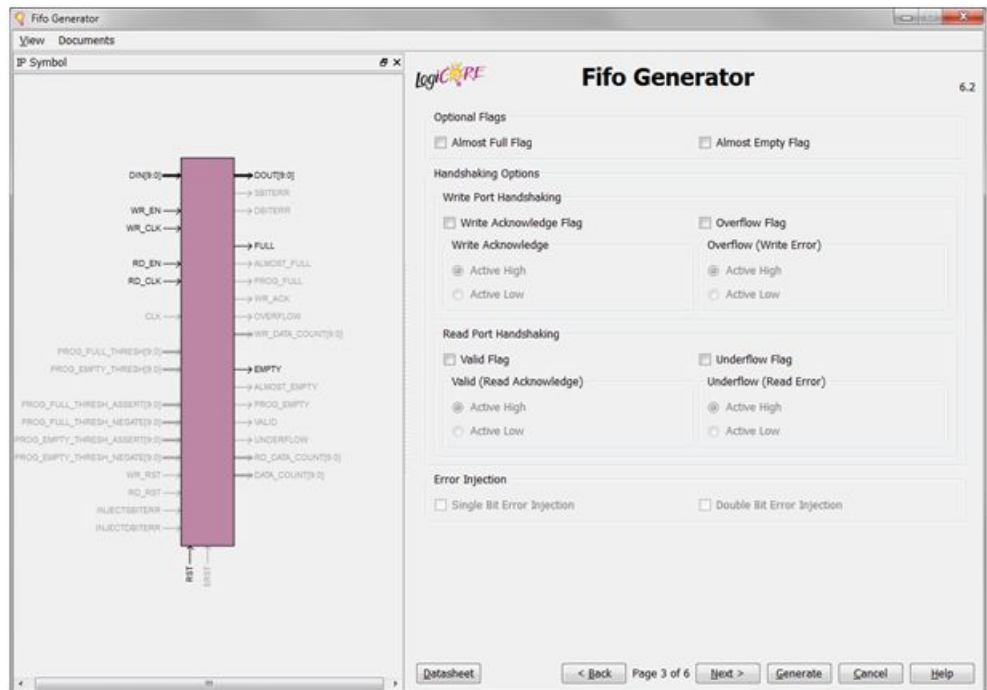

15. Use the default settings for **Initialization and Programmable Flags**. Click **Next**.

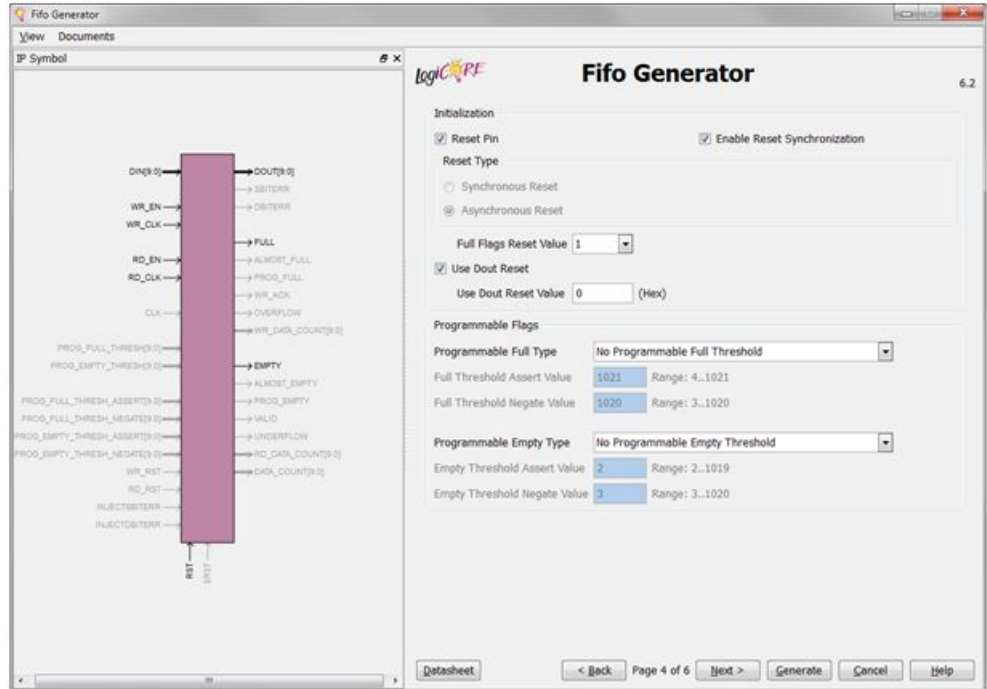

16. Set the **Write Data Count** and **Read Data Count** to 5. Click **Next**.

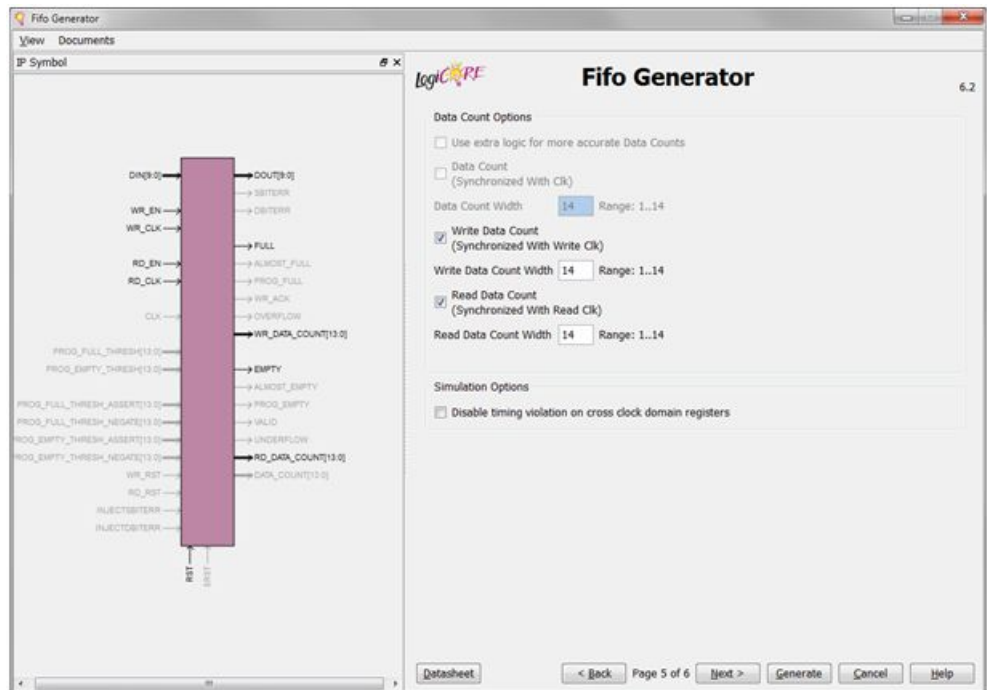

17. Click **Generate** to generate the FIFO core.

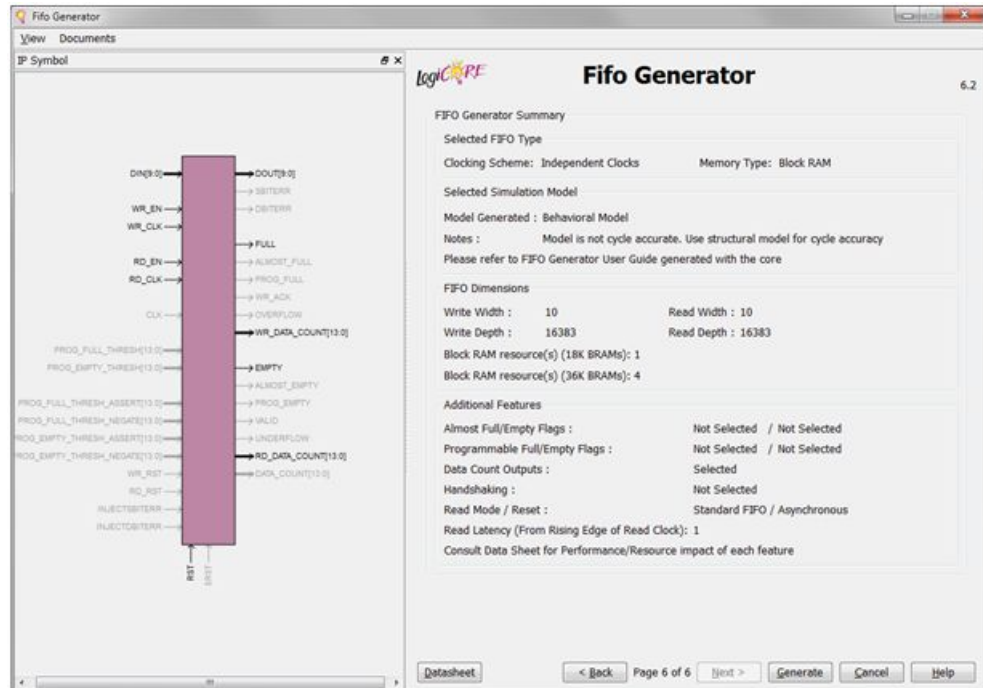

**Note** In this tutorial, the egress FIFO forwards a packet to the TX LocalLink First In First Out (FIFO) only when there is at least one complete packet in the egress FIFO. For this purpose, we add another FIFO to monitor the packet count in the egress FIFO.

18. Select **Project > New Source** to open the New Source Wizard. Select **IP (CORE Generator & Architecture Wizard)** and name the IP `count_fifo`. Click **Next**.

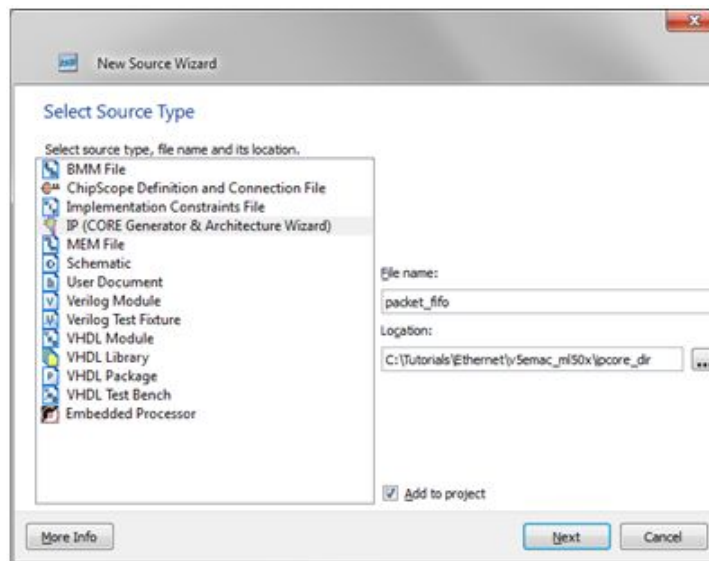

19. Select **Fifo Generator version 8.1** from the IP list. Click **Next** and then **Finish**.

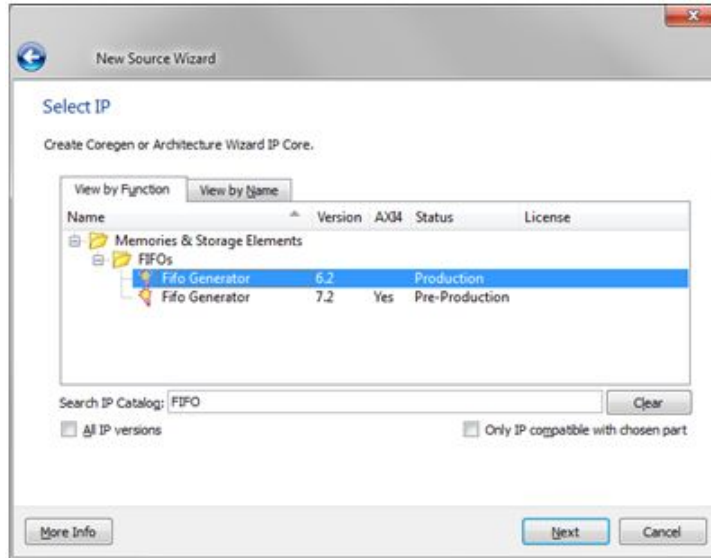

- When the Fifo Generator interface opens, set the **FIFO implementation to Independent Clocks (RD\_CLK, WR\_CLK) Distributed RAM**. Click Next.

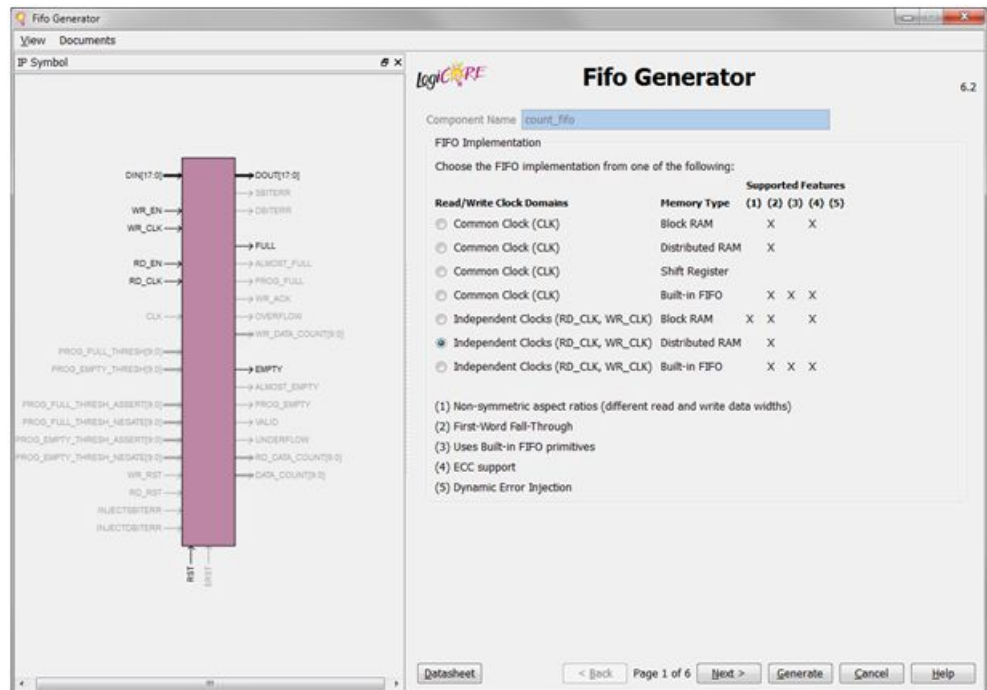

- Set the **Read Mode to First-Word Fall-Through**. Set the **Write Width and Read Width to 1**, and **Write Depth to 32**. Click Next.

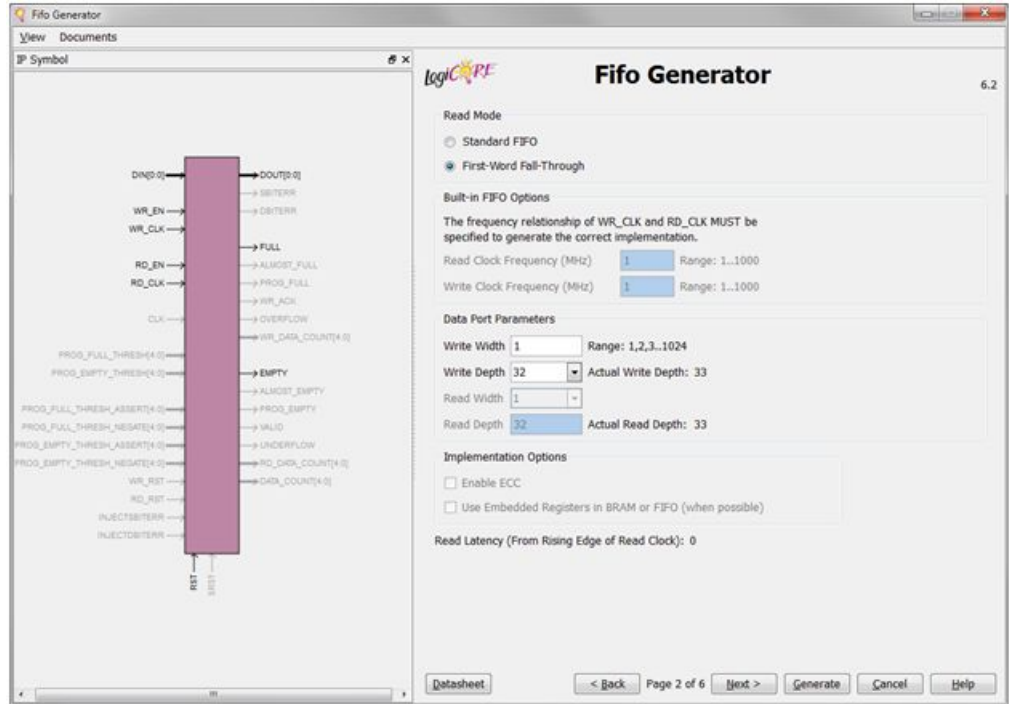

22. Use the default settings for **Optional Flags, Handshaking Options and Error Injection**. Click **Next**.

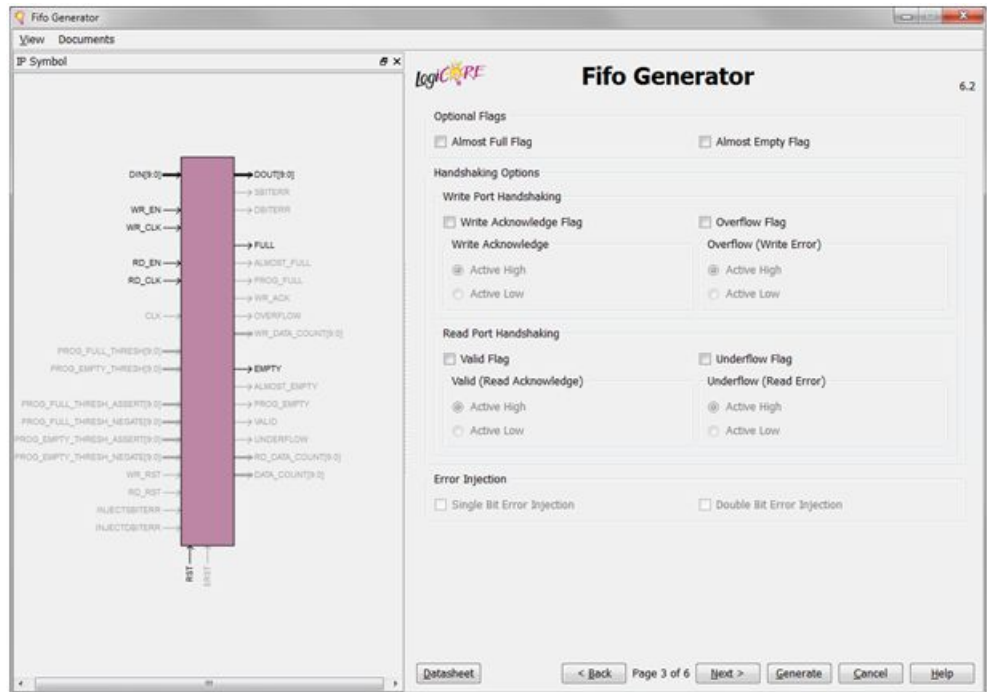

23. Use the default settings for **Initialization and Programmable Flags**. Click **Next**.

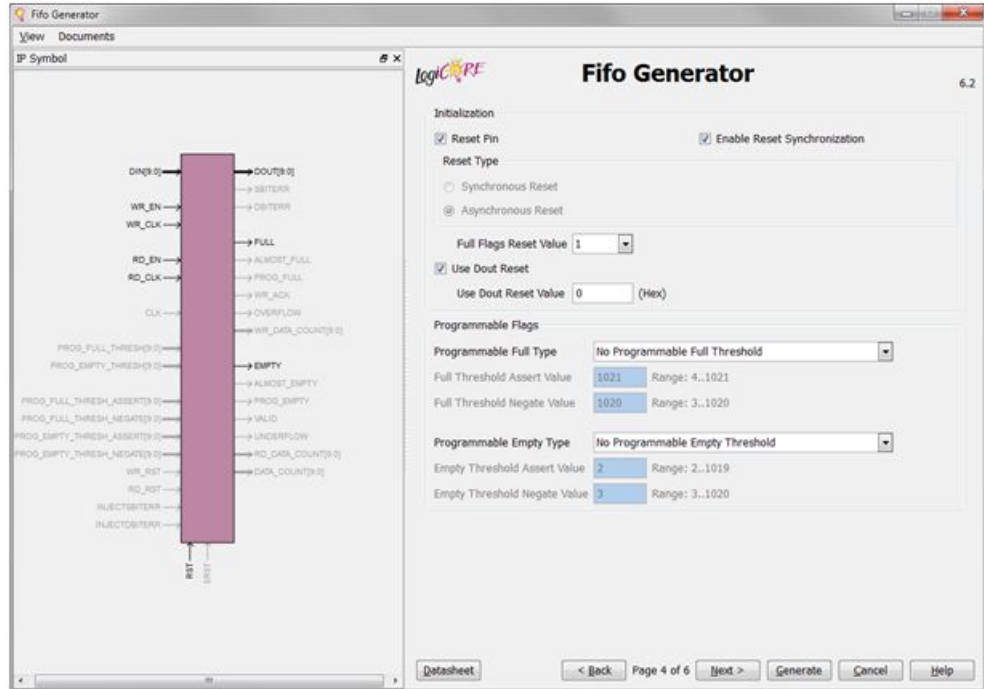

24. Set the **Write Data Count** and **Read Data Count** to 5. Click **Next**.

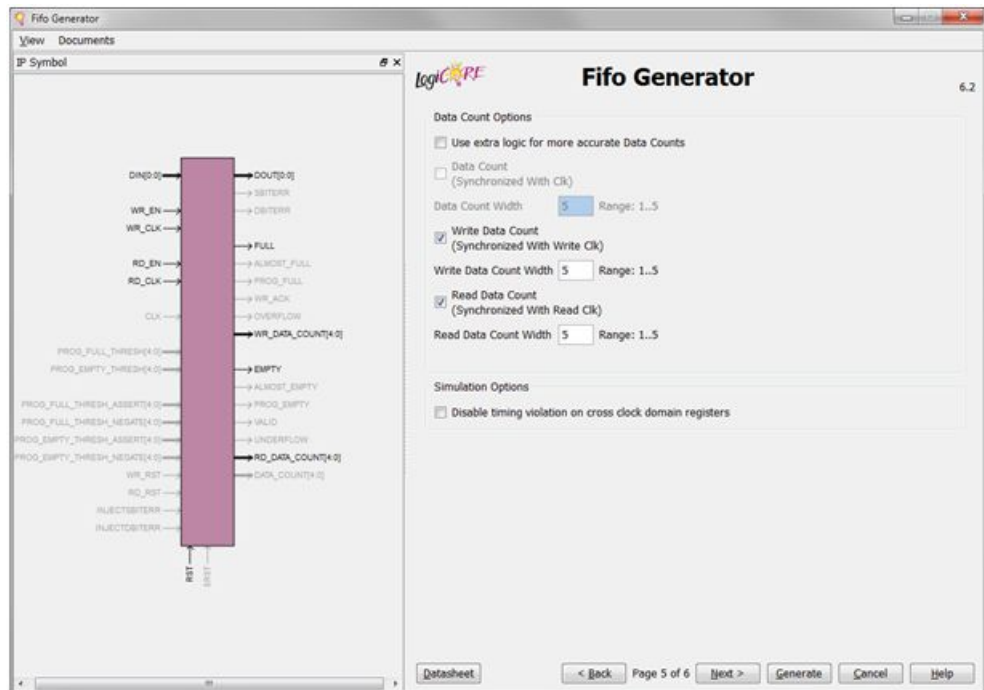

25. Click **Generate** to generate the FIFO core.

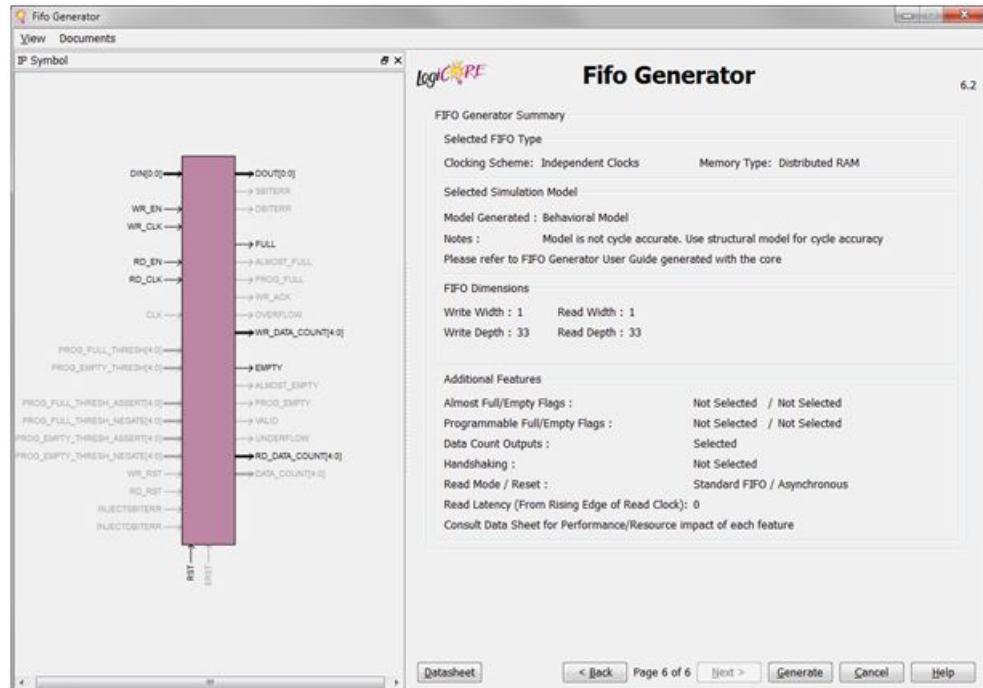

26. Add a top-level module `v5emac_top` that instantiates the `v5_emac_locallink` module, ingress FIFO, egress FIFO, and egress packet count FIFO. You can use the completed `v5emac_top.vhd` provided in this tutorial.
27. Select **Project > Add Source**. Add the `v5emac_top.vhd`.

## Step 2: Creating a Test Bench

1. Add a VHDL test bench module `v5emac_tb.vhd` that binds the `v5emac_top` instance to a packet processor. You can use the completed `v5emac_tb.vhd` file provided in this tutorial.
2. Select **Project > Add Source**. Add the `v5emac_tb.vhd` and `simple_arp.vhd`.

## Step 3: Creating a Custom Constraints File

### Partitioning the Design into Lock-Step and Free-Running Portions

The key concept of this tutorial is to partition the design into two portions:

- A free-running portion that interfaces with the external Ethernet PHY through the Virtex-5 Embedded Ethernet MAC. It connects to external I/Os and clocks, and runs at full clock speed required by the Ethernet interface
- A lock-step portion that is driven by the HDL test bench through ISim. It is synchronized to the ISim simulation, and receives stimuli and clock events virtually over the hardware co-simulation interface. As a result, it runs at a much lower speed.

The following figure shows how the Ethernet design is clocked under hardware co-simulation. The hardware co-simulation interface is inserted automatically during the compilation. It generates an emulated clock based on the 100 MHz user clock on the ML506 board. The emulated clock corresponds to the clock event on the `clk` signal in the test-bench and drives the `clk` port of `v5emac_top` running in hardware. The MGT clock for the Ethernet MAC is received from the 125 MHz differential clock on the ML506 board. The ingress and egress FIFO provide an asynchronous packet buffer for crossing domains between the emulated clock `clk` and the LocalLink interface clock `ll_clock`.

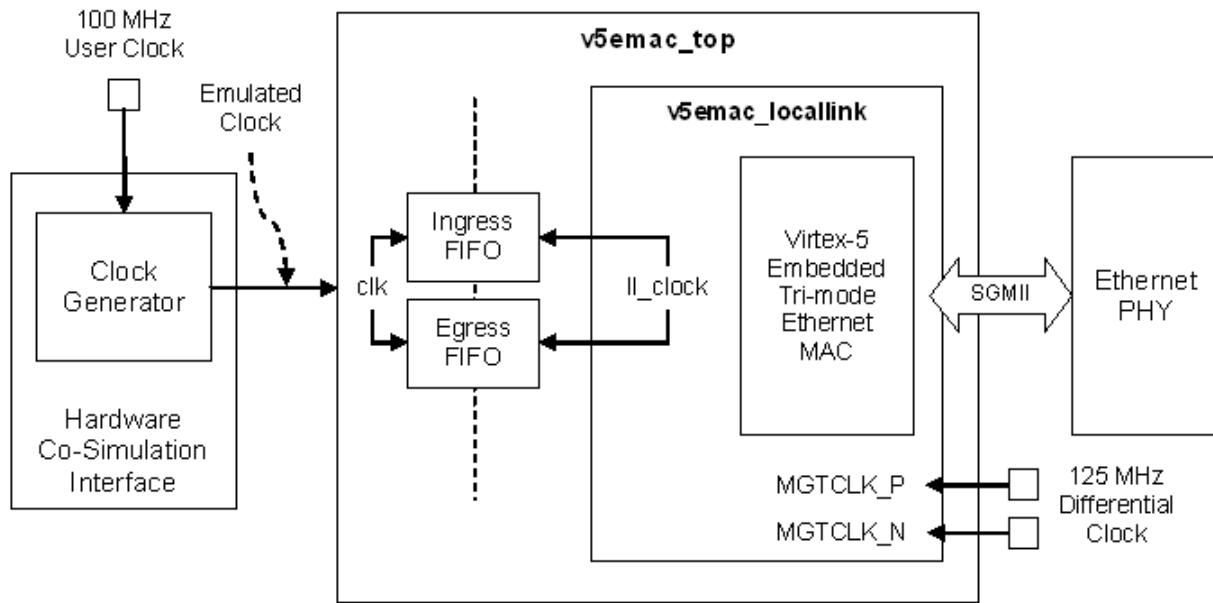

## Mapping Ports to External I/Os and Clocks

You can provide a custom constraints file, in Xilinx UCF format, to instruct the ISim compiler about which ports of the instance under hardware co-simulation are to be mapped to FPGA IOBs, and which ports are controlled by the HDL test bench. The ISim compiler looks for LOC constraints in the provided UCF file. A port with a LOC constraint is mapped to the corresponding FPGA IOB. A port without a LOC constraint is mapped to the hardware co-simulation interface and is accessible from the HDL test bench.

The partitioning of a design into a free-running portion and a lock-step portion happens implicitly based on how clock ports are mapped. If a clock port is mapped to an FPGA IOB via a LOC constraint, the logic driven by this clock belongs to the free-running portion. If a clock port has no LOC constraint assigned, the hardware co-simulation interface toggles the value on this port when a corresponding clock event occurs in the test bench. The logic driven by this clock therefore belongs to the lock-step portion.

Because the free-running and lock-step portion run at different speeds with separate clocks, the design should handle clock domain crossing between the two portions. The ISim hardware co-simulation compilation does not modify the internal of the design, and so it assumes the design can handle the speed difference and synchronization between the two portions.

The following table lists the ports on the `V5emac_top` module that are mapped to external I/Os, and those are controlled by the test bench.

## Partition of ports on the v5emac\_top module

Ports mapped to external I/Os	Ports controlled by the test bench
CTXP_0 TXN_0 RXP_0 RXN_0 MGTCLK_P MGTCLK_N PHY_RST_N	clk reset resetdone ingress_sof_n ingress_eof_n ingress_data ingress_rd_count ingress_re ingress_empty egress_sof_n egress_eof_n egress_data egress_wr_count egress_we egress_full count_we_o count_wr_count

The example design provided by Virtex-5 Embedded Tri-mode Ethernet MAC Wrapper has a UCF file, `ipcore_dir/v5emac/example_design/v5emac_example_design.ucf`. We are going to use it as a template to create the custom constraints file for hardware co-simulation.

1. Copy `ipcore_dir/v5emac/example_design/v5emac_example_design.ucf` to the ISE project directory where `v5_emac_top.vhd` is located. Name the copied file as `v5emac_hwcosim.ucf`.
2. Modify the `v5emac_hwcosim.ucf` file as follows for the ML506 board.
  - a. Comment out the area group constraints for the embedded Ethernet MAC.

```
#INST v5_emac_11/* AREA_GROUP = AG_v5_emac ;
#AREA_GROUP "AG_v5_emac" RANGE = CLOCKREGION_X1Y2,CLOCKREGION_X1Y3 ;
```

Change the LOC constraints of MGTCLK\_P and MGTCLK\_N to P4 and P3, respectively, if the default values are different.

```
INST "MGTCLK_N" LOC = "P3";
INST "MGTCLK_P" LOC = "P4";
```

- b. Change the LOC constraint of GTP primitive from GTP\_DUAL\_X0Y2 to GTP\_DUAL\_X0Y3.

```
INST "*GTP_DUAL_1000X_inst?GTP_1000X?tile0_rocketio_wrapper_i?gtp_dual_i" LOC = "GTP_DUAL_X0Y3";
```

- c. Enable auto-negotiation by default on EMAC0 of the Ethernet MAC primitive.

```
INST "*?v5_emac" EMAC0_PHYINITAUTONEG_ENABLE = TRUE;
```

- d. Add the LOC constraint for TXN\_0, TXP\_0, RXN\_0, RXP\_0, and PHY\_RST\_N to match the pin assignments on ML506.

```
INST "TXN_0" LOC = "N2";
INST "TXP_0" LOC = "M2";
INST "RXN_0" LOC = "P1";
INST "RXP_0" LOC = "N1";
INST "PHY_RST_N" LOC = "J14";
```

3. Modify the `v5emac_hwcosim.ucf` file for ISim hardware co-simulation requirements.

- a. Add a wildcard character "\*" at the beginning of the hierarchical path for the following constraints. This is required because the `v5emac_locallink` will be wrapped as a submodule when it is compiled for hardware co-simulation.

```
NET "*clk125" TNM_NET = "clk_gtp" ;
```

- b. Put a timing ignore constraints (TIG) on the `resetdone` signal to avoid any timing error as it will be monitored by the ISim test bench.

```
NET "*resetdone" TIG;
```

## Step 4: Compiling the Design for Hardware Co-Simulation

Once you have created the test bench and the custom constraints file, you can compile the design for hardware co-simulation using the ISim compiler. This can be done in Project Navigator by enabling hardware co-simulation on a selected instance in your design. The selected instance, including its submodules, will be co-simulated in hardware during the ISim simulation. Other modules will be simulated in software.

1. Switch to the **Simulation View** in Project Navigator. Right-click on the `v5emac_dut - v5emac_top` instance from the **Pane** of the Design panel and click **Source Properties**.

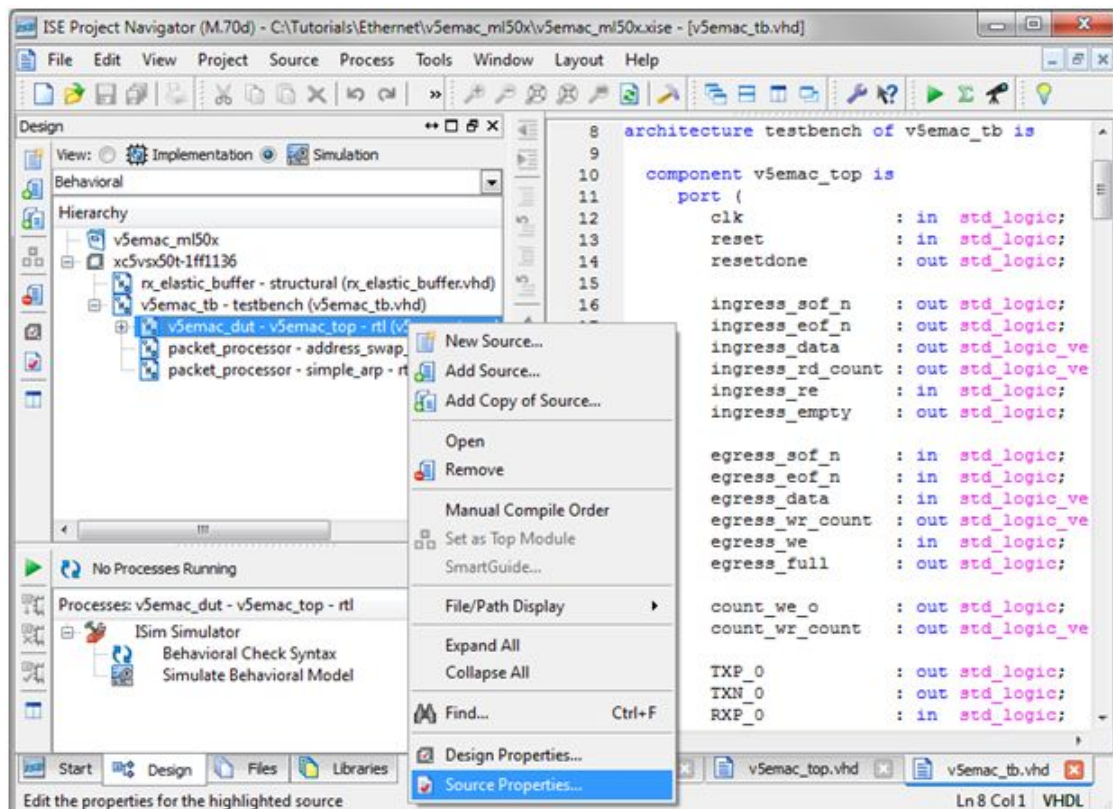

2. Select the **Hardware Co-Simulation** category. Check the **Enable Hardware Co-Simulation** checkbox. Set the **Clock Port** to `clk`. Select **ML506 (JTAG)** as the **Target Board for Hardware Co-Simulation**.

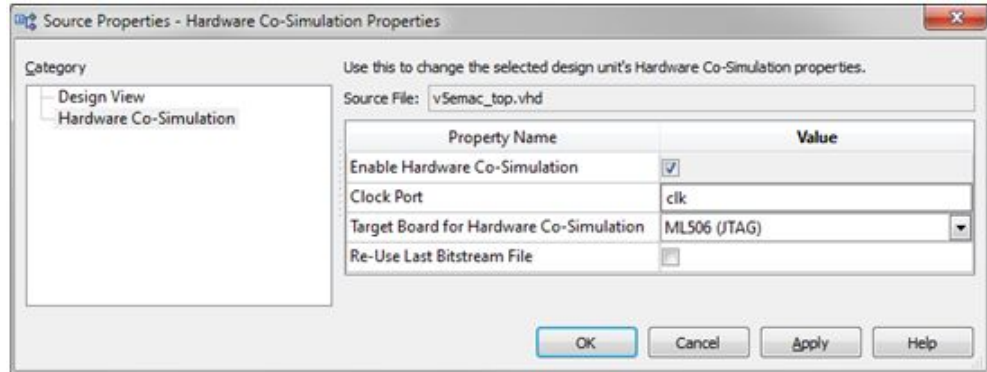

**Note** The instance enabled for hardware co-simulation is now marked with a special icon .

If the instance selected for hardware co-simulation does not change in subsequent runs, you can turn on the **Enable Incremental Implementation** option to skip the synthesis, implementation, and bitstream generation for hardware co-simulation. It allows the test bench or any portion simulated in software to be modified and simulated again quickly.

3. Select the **v5emac\_tb** instance from the **Pane** of the Design panel. Go to the **Pane** of the Design panel, right-click on **Simulate Behavioral Model**, and click **Process Properties**.

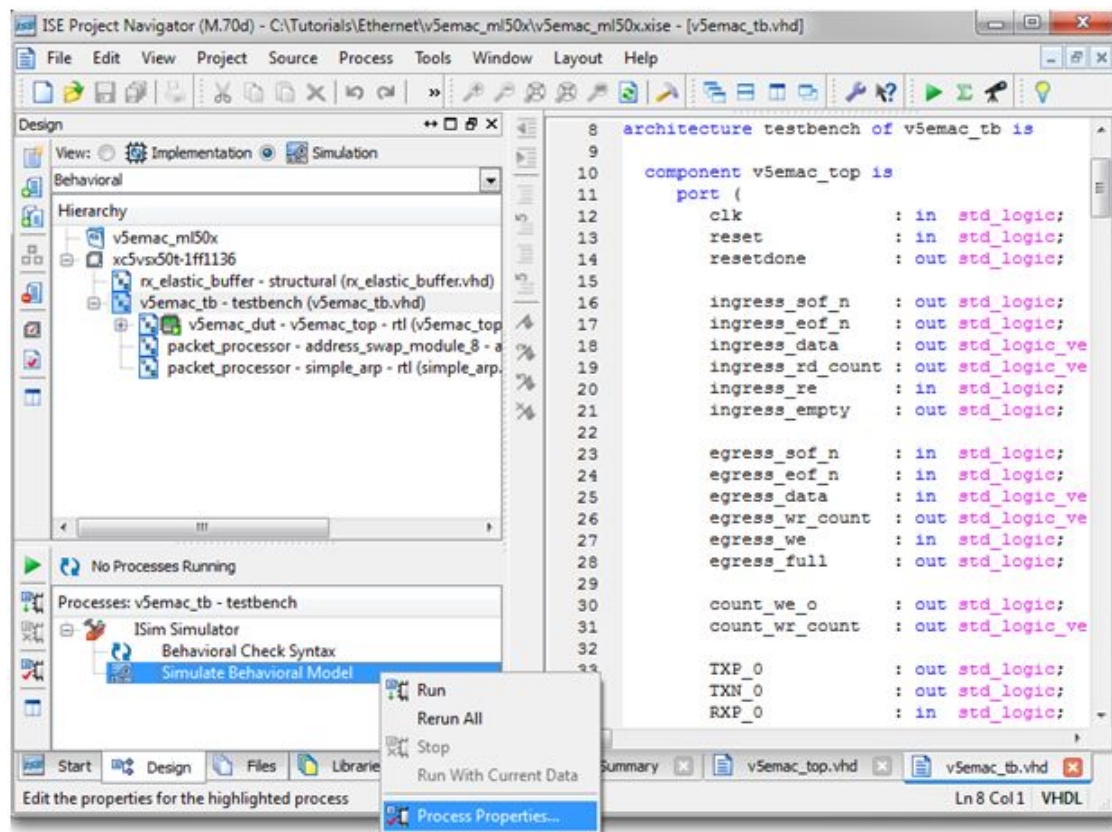

4. Change the **Property** display level to **Advanced**. Set the following properties for the **Simulate Behavioral Model** process:
  - Check **Use Custom Simulation Command File**.

- Set **Custom Simulation Command File** to **init.tcl**.
- To set this option, the **Use Custom Waveform Configuration File** needs to be checked.
- Set **Other Compiler Options** to **-hwcosim\_constraints v5emac\_hwcosim.ucf**.

The `init.tcl` script is executed when the ISim simulation starts. It runs the simulation for 50 ns to perform an initial reset of the design.

The `v5emac_tb.wcfg` file provides a customized waveform configuration view for this tutorial.

**Note** The custom constraints file for hardware co-simulation is provided to the ISim compiler through the `-hwcosim_constraints` switch. This property is currently not accessible in the Project Navigator GUI, so that we specify it through the Other Compiler Options.

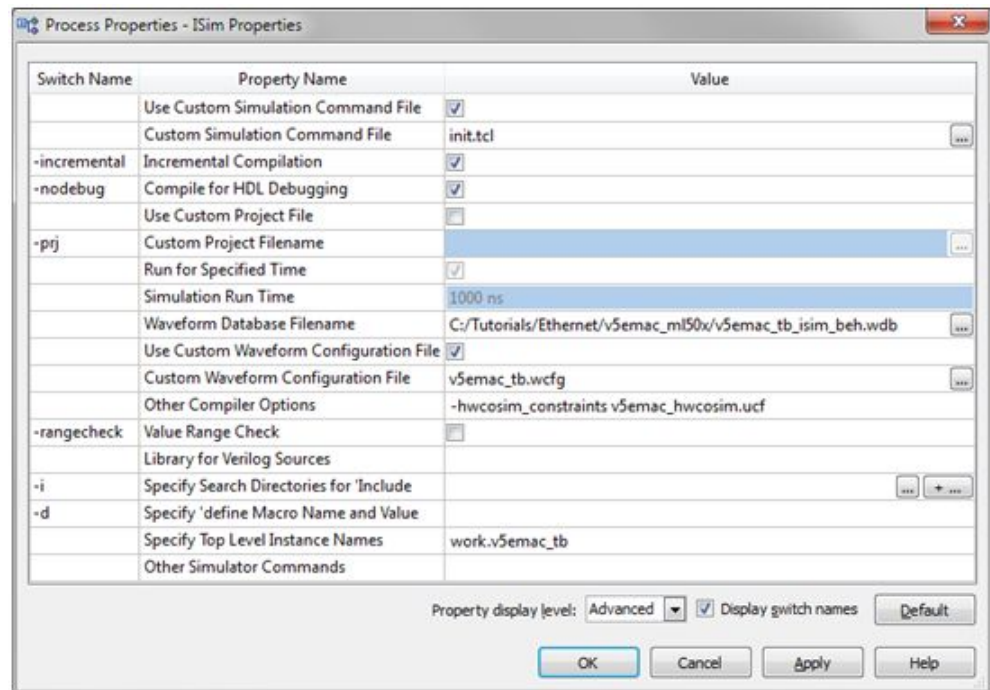

5. Run the **Simulate Behavioral Model** process for the `v5emac_tb` instance.

## Compiling from the Command Line

The ISim compiler can be invoked through the Fuse command line tool. As in the pure software simulation flow, you need to provide Fuse a project file, the design top-level module(s), and other optional arguments such as libraries to link in and library search paths. To compile the design for hardware co-simulation, you need to provide the extra arguments listed below:

```
fuse -prj <project file> <top level modules>
      -hwcosim_instance <instance>
      -hwcosim_clock <clock>
      -hwcosim_board <board>
      -hwcosim_constraints <constraint file>
      -hwcosim_incremental <0|1>
```

- `hwcosim_instance` specifies the full hierarchical path of the instance to co-simulate in hardware.
- `hwcosim_clock` specifies the port name of the clock input for the instance.
  - This is the clock in the lock-step portion, which is to be controlled by the test bench.
  - For a design with multiple clocks, specify the fastest clock using this option so that ISim can optimize the simulation. Other clock ports are treated as regular data ports.
- `hwcosim_board` specifies the identifier of the hardware board to use for co-simulation. A few Virtex-5 boards are supported by default:
  - `ml501-jtag`: Xilinx ML501 Evaluation Platform
  - `ml505-jtag`: Xilinx ML505 Evaluation Platform
  - `ml506-jtag`: Xilinx ML506 Evaluation Platform
  - `ml507-jtag`: Xilinx ML507 Evaluation Platform
  - `ml510-jtag`: Xilinx ML510 Evaluation Platform
  - `xupv5-jtag`: Xilinx XUPV5-LX110T Evaluation Platform
- `hwcosim_constraints` (optional) specifies the custom constraints file that provides additional constraints for implementing the instance for hardware co-simulation. We also use the constraints file to specify which ports of the instance are mapped to external I/Os or clocks.
- `hwcosim_incremental` (optional) specifies whether Fuse should reuse the last generated hardware co-simulation bitstream and skip the implementation flow.

For example, to compile the EMAC design for this tutorial, you can run the Fuse command line as follows:

```
fuse -prj v5emac_tb.prj v5emac_tb
      -o v5emac_tb.exe
      -hwcosim_instance /v5emac_tb/v5emac_dut
      -hwcosim_clock clk
      -hwcosim_board ml506-jtag
      -hwcosim_constraints v5emac_hwcosim.ucf
```

## Step 5: Running ISim Hardware Co-Simulation

The simulation executable generated by the ISim compiler runs in the same way in both the pure software simulation and hardware co-simulation flow. Project Navigator automatically launches the simulation executable in GUI mode after the compilation finishes.

In the Instances and Processes view, a special icon  indicates that an instance is selected for hardware co-simulation. As the instance runs in hardware, you cannot expand it to see its internal signals and submodules.

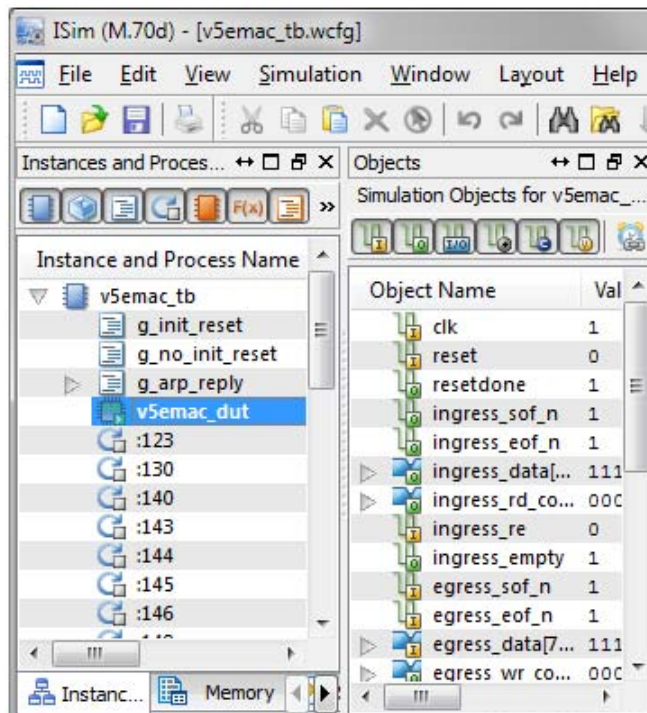

Before the simulation starts, ISim programs the FPGA with the bitstream file generated for hardware co-simulation. You may notice the message in the ISim console window: `Downloading bitstream, please wait till status is READY.` After the FPGA is configured, the console shows `Bitstream download is complete. READY for simulation.` From this point, you can run the simulation and interact with the ISim interface the same way you do in the software simulation flow.

The test bench initially resets the system by asserting the reset signal. The **resetdone** signal transits from low to high quickly after the reset is de-asserted. This is because the reset process takes place in hardware at full speed. It may take a much longer time if the same process is simulated in software.

The screenshot shows the ISim (M.70d) simulation environment for the v5emac\_tb.wcfg project. The main window is divided into several panels:

- Instances and Proc...:** Shows the component hierarchy, including v5emac\_tb and its sub-components like q\_init\_reset, q\_no\_init\_reset, q\_arp\_reply, and v5emac\_dut.
- Objects:** Displays a list of simulation objects and their current values. The table below shows the objects listed in the screenshot:

Object Name	Value
clk	1
reset	0
resetdone	1
ingress_sof_n	1
ingress_eof_n	1
ingress_data[...]	1111111
ingress_rd_co...	0000000
ingress_re	0
ingress_empty	1
egress_sof_n	1
egress_eof_n	1
egress_data[7...]	1111111
egress_wr_co...	0000000
egress_we	0
egress_full	0
count_we_o	0
count_wr_co...	00000
txp_0	0
txn_0	0
rxp_0	2
rxn_0	2
mgclk_p	2
mgclk_n	2
phy_rst_n	0

The waveform viewer shows digital signals over time, with a 50 ns scale bar. The console at the bottom displays the following messages:

```
ISim M.70d (signature 0x16fbc694)
This is a Full version of ISim.
Time resolution is 1 ps
Simulator is doing circuit initialization process.
at 0 ps: Note: Downloading bitstream, please wait till status is READY.
(/v5emac_tb/v5emac_dut/).
at 0 ps: Note: Bitstream download is complete. READY for simulation.
(/v5emac_tb/v5emac_dut/).
Finished circuit initialization process.
ISim>
```

The console also shows buttons for Console, Breakpoints, Find in Files Results, and Search Results. The simulation time is 50,000 ps.

If the Ethernet MAC receives packets, the packets are forwarded from RX LocalLink FIFO to ingress FIFO. When the test bench runs for a few thousand nanoseconds, it starts to read packets out from the ingress FIFO. The ISim console prints out a message like receive a packet at 110 ns when there is a packet read from the ingress FIFO. You can also observe the packet data (ingress\_data) from the ISim waveform. If you run the ISim simulation continuously (using the **Run All** command), you can observe the packet stream and how the packet processor processes the packets. As a validity check, you can install a third-party packet sniffer such as Wireshark (<http://www.wireshark.org>) to compare the packets captured by the ISim test bench, and the ones captured by the sniffer.

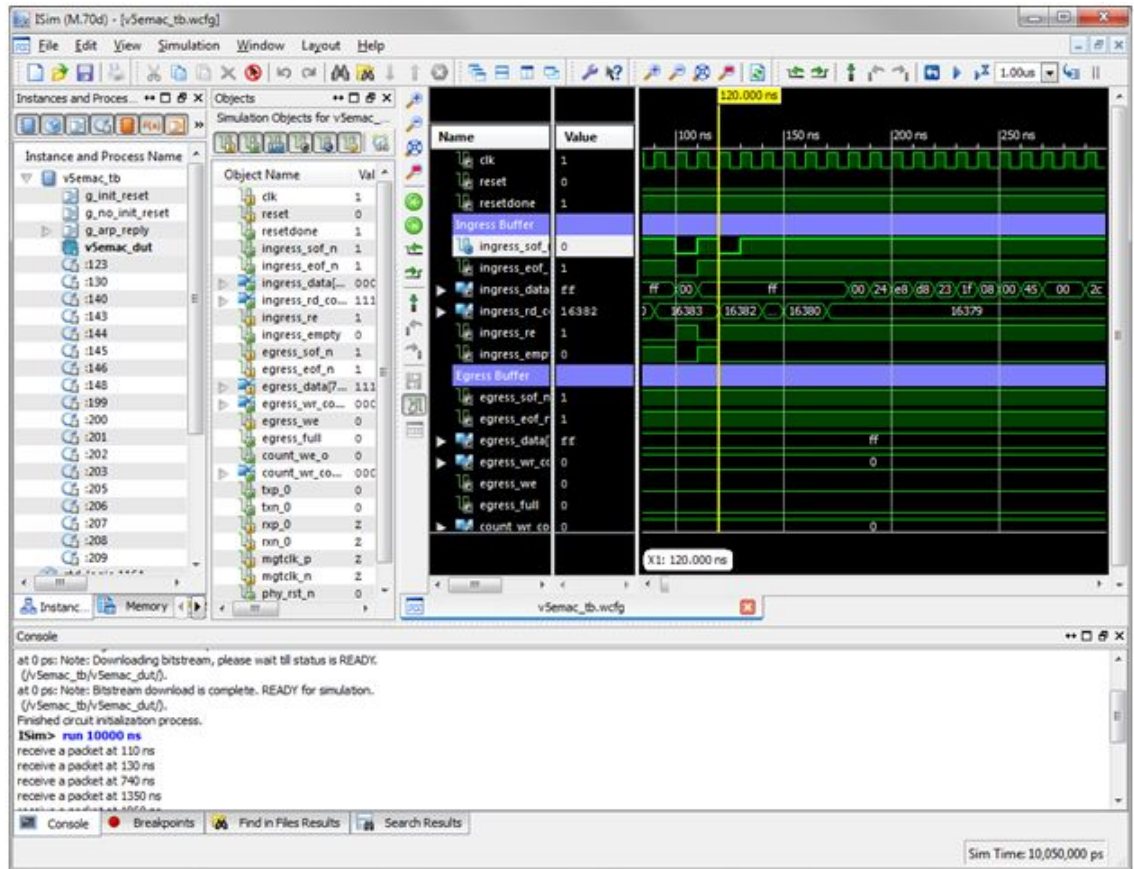

Now you can modify your packet processor in your test bench and quickly recompile the ISim test bench with the **Enable Incremental Implementation** turned on in the Hardware Co-Simulation properties. This substantially speeds up the develop-compile-debug cycle for your HDL design.



## *Additional Resources*

---

- **Xilinx Glossary** - [http://www.xilinx.com/support/documentation/sw\\_manuals/glossary.pdf](http://www.xilinx.com/support/documentation/sw_manuals/glossary.pdf)
- **Xilinx Documentation** - <http://www.xilinx.com/support/documentation>
- **Xilinx Support** - <http://www.xilinx.com/support>