

Hierarchical Design Methodology Guide

UG748 (v13.4) January 18, 2012



Xilinx is disclosing this user guide, manual, release note, and/or specification (the “Documentation”) to you solely for use in the development of designs to operate with Xilinx hardware devices. You may not reproduce, distribute, republish, download, display, post, or transmit the Documentation in any form or by any means including, but not limited to, electronic, mechanical, photocopying, recording, or otherwise, without the prior written consent of Xilinx. Xilinx expressly disclaims any liability arising out of your use of the Documentation. Xilinx reserves the right, at its sole discretion, to change the Documentation without notice at any time. Xilinx assumes no obligation to correct any errors contained in the Documentation, or to advise you of any corrections or updates. Xilinx expressly disclaims any liability in connection with technical support or assistance that may be provided to you in connection with the Information.

THE DOCUMENTATION IS DISCLOSED TO YOU “AS-IS” WITH NO WARRANTY OF ANY KIND. XILINX MAKES NO OTHER WARRANTIES, WHETHER EXPRESS, IMPLIED, OR STATUTORY, REGARDING THE DOCUMENTATION, INCLUDING ANY WARRANTIES OF MERCHANTABILITY, FITNESS FOR A PARTICULAR PURPOSE, OR NONINFRINGEMENT OF THIRD-PARTY RIGHTS. IN NO EVENT WILL XILINX BE LIABLE FOR ANY CONSEQUENTIAL, INDIRECT, EXEMPLARY, SPECIAL, OR INCIDENTAL DAMAGES, INCLUDING ANY LOSS OF DATA OR LOST PROFITS, ARISING FROM YOUR USE OF THE DOCUMENTATION.

© Copyright 2012 Xilinx Inc. All Rights Reserved. XILINX, the Xilinx logo, the Brand Window and other designated brands included herein are trademarks of Xilinx, Inc. All other trademarks are the property of their respective owners. The PowerPC name and logo are registered trademarks of IBM Corp., and used under license. All other trademarks are the property of their respective owners.

Revision History

Date	Version	Revision
03/01/2011	13.1	<ul style="list-style-type: none">• Added new chapter on Team Design Flow.• Added new information on:<ul style="list-style-type: none">• Black box support• ImportTag• Memory Reduction scheme
07/06/2011	13.2	<ul style="list-style-type: none">• Under <i>Partition States</i>, added information on setting a partition state to auto.• Added new section <i>Partitioning Processor Systems</i>.• Added new section <i>Updated Attributed Value Not Used on Imported Partition</i>.• Indicated where support is limited for some functionality to Virtex®-6, Spartan®-6, and Xilinx® 7 series FPGA devices only.• Added new information on <i>Setting the ImportTag Attribute</i>, including <i>Setting the ImportTag Attribute from the Tcl Console</i>.• Under <i>Managing the Preservation Attribute</i>, corrected command to Specify Partitions instead of Implementation Settings.
10/19/2011	13.3	<ul style="list-style-type: none">• Clarified first step in <i>Exporting PXML Files</i>.• Added information on PREV files in <i>Exporting Partitions</i>.• Clarified distinction between “top level” and “top partition.”• Added information to section <i>Floorplan Team Member Blocks to a Specific Region</i>.
01/18/2012	13.4	<ul style="list-style-type: none">• Added note in Chapter 1, Partitions, explaining that the Stacked Silicon Interconnect (SSI) technology is not supported in the Xilinx ISE® Design Suite.

Table of Contents

Revision History	3
Chapter 1: Partitions	
PXML Files	9
Deciding When to Use Partitions	9
Costs and Benefits of Using Partitions	10
Partition States	10
Partition Changes That Require Re-Implementation	11
Partition Changes That Do Not Require Re-Implementation	11
Partition Preservation Levels	12
Import Location	12
Importing With Different Hierarchy	13
Managing Memory Usage on Large Designs	14
Black Box Usage	15
Partition Context Rules	17
Chapter 2: Design Considerations	
Optimization Limitations	19
Using BoundaryOpt to Optimize IP Cores	22
Architecting the Design	24
Achieving the Benefits of an HD Flow	25
Limitations on Preserving Routing Information	27
Floorplanning Partitions	28
Partitioning Processor Systems	29
Chapter 3: Synthesis Partition Flow	
Incremental Synthesis Partition Flow	31
Bottom-Up Synthesis Partition Flow	32
Synthesis Tools	32
Chapter 4: Command Line Partition Flow	
Xilinx Implementation Tools	39
Creating a PXML File	39
Running Implementation	42
Exporting Partitions	43
Updating Partition State to Import	44
Iterative Design	45
Using SmartXplorer in Partitioned Designs	45

Removing and Restoring Partitions	46
---	----

Chapter 5: PlanAhead Tool Partition Flow

About the PlanAhead Tool Partition Flow	49
Creating a New Project	50
Creating Partitions	50
Importing PXML Files	50
Exporting PXML Files	51
Setting the BoundaryOpt Attribute	51
Setting the ImportTag Attribute	51
Floorplanning Partitions	52
Synthesizing a Partitioned Design	52
Implementing a Partitioned Design	53
Promoting Partitions	54
Managing Partition Attributes	54
Managing Design Runs	56

Chapter 6: Design Preservation Flows

Implementation Runtime	57
Command Line Design Preservation Flow	58
PlanAhead Tool Design Preservation Flow	59
Netlist Design Preservation Flow	60

Chapter 7: Team Design Flows

Team Design Flow Team	61
Team Design Flow Overview	62
Team Design Flow Setup	63
Team Member Responsibilities	68
Team Leader Responsibilities	70
Design Recommendations for All Partition-Based Designs	74
Design Recommendations for Team Design Flow Only	74
Command Line Flow	77
PlanAhead Tool Flow	81
Interface Timing	82

Chapter 8: Debugging Partitions

Implementation Errors	87
Updated Attributed Value Not Used on Imported Partition	91
BitGen DRC Errors	91
ChipScope Support	91

Appendix A: Additional Resources

Xilinx Resources	81
ISE Documentation	81
PlanAhead Tool Documentation.....	81

Partitions

In Hierarchical Design (HD) flows, a design is broken up into blocks called *partitions*. These partitions:

- Are the building blocks of Xilinx® HD flows.
- Define hierarchical boundaries.
- Allow complex designs to be broken up into smaller, more manageable pieces.
- Create boundaries or insulation around the hierarchical module instances, isolating them from other parts of the design.
- Can be re-inserted into the design using copy-and-paste once the partition has been implemented and exported. This preserves the placement and routing results of the module instance.

Note: The Xilinx ISE® Design Suite does not support the Stacked Silicon Interconnect (SSI) technology. SSI is therefore not supported in Hierarchical Design (HD) flows.

PXML Files

Partition definitions and controls are specified in the PXML file.

The PXML file:

- Is named `xpartition.pxml`
- Is read when the tools are run.
- Can be created:
 - By hand, with or without using the PXML template, or
 - Using the PlanAhead™ design tool graphical user interface (GUI)

For information on creating PXML files, see [Chapter 4, Command Line Partition Flow](#).

Deciding When to Use Partitions

Use partitions only on modules that need them. Over-using partitions can increase runtime and decrease performance.

A flat optimization provides the best results for modules that:

- Are not an isolated functional block in their own hierarchy, or
- Will benefit from global optimization with other blocks.

To use partitions successfully, see [Chapter 2, Design Considerations](#).

Candidates for using partitions are:

- Functional blocks, such as:
 - DSP module
 - EDK system
- High performance cores.
- Instances containing logic that must be packed or placed together within the device.
- Modules that follow good design practices.

Costs and Benefits of Using Partitions

An HD flow has both costs and benefits. When using partitions, the resulting hierarchical boundary affects optimization. Optimization cannot take place across a partition boundary.

If a design does not account for this limitation, partitions can significantly impact timing, utilization, and runtime. Even with careful planning, other optimization and packing limitations can increase utilization and negatively impact timing. While these effects are usually minimal for well-architected designs, you must take them into account.

For more information on how partitions affect optimization, and how to design to minimize these effects, see [Chapter 2, Design Considerations](#).

Partition States

A partition can be *implemented* or *imported* depending on the partition state.

Setting the Partition State to Implement

The first time a partition is run through the ISE Design Suite implementation tools, set the partition state to *implement*. The implementation tools include:

- NGDBuild
- Map
- PAR

Exporting the Partition

After implementation completes, a partition can be *exported* so that the results can be *imported* for a future run.

The exported results are valid for *future* implementations only, provided the internal logic and the partition interface have not changed.

Setting the Partition State to Auto

A partition can also have its state set to **auto**.

Setting the partition state to **auto** directs NGDBuild to:

- *Import* partitions that *have not* logically changed.
- *Implement* partitions that *have* logically changed.

The **auto** state:

- Is supported only from the command line flow.
- Requires the **ImportLocation** attribute to be defined.

The directory specified by **ImportLocation** may be empty initially, but should be the location to which successfully implemented partitions are exported.

- The **auto** state can be used only to handle logical changes to the design that are processed by NGDBuild.
 - Physical changes to the design such as changing a LOC or AREA_GROUP constraint are not processed until Map.
 - The state must be manually changed to *implement*.

Partition Changes That Require Re-Implementation

When a partitioned module is changed, the placement and routing information for that partition becomes out of date. You must re-implement the modified partition. You can import unchanged partitions from a previous run.

Partition changes that require re-implementation include:

- Changes to the Hardware Description Language (HDL) code.
- Any other changes that modify the netlist associated with a partition.
- Changes to the physical constraints associated with a partition, including (not handled by **state=auto**):
 - AREA_GROUP
 - LOC
- Changes to the target architecture, including:
 - Device
 - Package
 - Speed grade
- Adding or changing connections on a ChipScope™ Analyzer core that is connected to the partition.
- Context changes to the partition interface.
See [Partition Context Rules](#) in this chapter.

If an exported partition becomes out of date, set the **state** attribute in the PXML file to manage the partition state. Failing to do so results in implementation errors.

Partition Changes That Do Not Require Re-Implementation

Partition changes that do not require re-implementation include:

- Constraint changes that do not affect the physical location of logic. Example: TIMESPEC
- Changes to implementation options that differ from those used by the original partition. Example: **par -xe**

Partition Preservation Levels

Partitions preserve the results of a run by importing previous results.

When importing a partition, you can:

- Specify the level of preservation. The default is to preserve 100% placement and routing.
- Modify the default to preserve:
 - Placement results
Routing can be modified.
 - Synthesis results
Placement and routing can be modified.
- Make small changes based on the preservation level in order to:
 - Improve timing
 - Resolve placement or routing conflicts.

Regardless of the preservation level, the import initially copies in all placement and routing information for an imported partition.

The preservation level determines how much flexibility the implementation tools have to modify the imported placement and routing. Relaxing preservation levels can free up device resources, giving the tools greater flexibility to place and route other partitions.

The preservation level:

- Can be set per partition.
- Can apply to imported partitions only.

If a timing critical partitioned module has met timing, and no changes are expected (for example, an IP core), the *routing* preservation level is a good choice.

If a partition is not timing critical, or has not yet met timing, relaxing the preservation level gives the tools greater flexibility to find a solution.

If your goal in using partitions is to reduce verification time, set the preservation level to *routing*. Re-verify the partition if the preservation level must be changed in order to:

- Meet timing, or
- Finish routing another part of the design.

Floorplanning partitions sometimes reduces the need to relax the preservation level.

Import Location

When *importing* a partition, you must specify the location of the exported results.

When *exporting* an implemented design, every partition in the design is exported with it.

For flows such as team design or serial buildup, a design run can import partitions from multiple locations, or from multiple exported designs.

Importing With Different Hierarchy

A partition can be imported into a different hierarchy than the hierarchy originally used to implement the partition.

To import a partition to a different level of hierarchy, use the **ImportTag** attribute in the PXML file. Use cases include:

- Top level block changes name between variants of same design (such as Top, Top2).
- The partition is:
 - Implemented with minimal other logic (top level with clocks and I/O).
 - Added to the full design where the hierarchy changes.
- The partition is being imported into a completely different hierarchy. The connections to the inputs and output of the partitions must be consistent (same context).

The **ImportTag** attribute:

- Is supported in:
 - Xilinx Synthesis Technology (XST) synthesis
 - ISE Design Suite implementation
- Can be defined:
 - Manually in:
 - the PXML file
 - in a command line flow
 - Using an attribute in the PlanAhead tool

For more information on setting **ImportTag** in the PlanAhead tool, see [Chapter 5, PlanAhead Tool Partition Flow](#).

The *value* of the **ImportTag** attribute is the *name* of the original partition being imported. The new hierarchy is defined by the partition name.

Consider a partition originally defined and implemented with:

```
Partition Name="/iptop/ip"
```

This partition was then exported and used in a new design with:

```
Partition Name = "/top/x/y"
```

In order to import the partition named **"/iptop/ip"** into **"/top/x/y"** set the **ImportTag** attribute to:

```
ImportTag = "/iptop/ip"
```

Managing Memory Usage on Large Designs

Partitions usually increase the total peak memory requirement. In most cases, this increase is relatively minor. As designs become larger -- in the range of 100,000 plus slice count -- memory usage may increase at higher rates. This increase is due to the size of the Netlist Constraint Definition (NCD) files from which the partitions are being imported.

For designs with multiple partitions, use the following methods to reduce the increase in memory requirements:

- [Define Partitions as Black Boxes](#)
- [Define Partitions With Minimal Logic](#)

Define Partitions as Black Boxes

Partitions can be defined as black boxes in synthesis and implementation.

Advantages to Defining Partitions as Black Boxes

If a design is implemented with one partition that contains logic, and other partitions are defined as black boxes:

- The resulting NCD file is smaller.
- There is less total logic in the design.
- Runtime is usually reduced.
- Because the implementation tools act on a smaller percentage of the design, timing results inside the partition might improve.

The more of the design that can be black boxed:

- The smaller the resulting NCD file
- The greater the memory reduction during the import run

This process is repeated until all partitions are implemented and exported to unique locations. A final run imports each partition from the appropriate location.

This method is similar to the flow described in [Chapter 7, Team Design Flows](#).

Disadvantages to Defining Partitions as Black Boxes

When defining partitions as black boxes, the interface timing to and from the partitions might not be met when the final design is assembled.

Because other partitions are defined as black boxes while another is being implemented, timing paths connected to the missing logic are not constrained by existing constraints. The connections to the black boxed modules still exist, but the connection is to proxy logic (which is implemented as a LUT1).

Timing constraints to and from the proxy logic can be created using:

- FROM:TO constraint
- **TPSYNC** or **PPS**

For examples of constraints on proxy logic in black box modules, see [Black Box Usage](#) in this chapter.

Define Partitions With Minimal Logic

An alternative to using proxy logic and black box modules is to define a version of the partitions with minimal logic.

The required logic consists of the interface connections necessary to obtain realistic timing results using the existing constraints. Registering the inputs and outputs usually satisfies this requirement.

Because the partitions other than the one being implemented have minimal logic:

- The resulting NCD file is much smaller than the full design.
- The desired memory reduction still takes place.

The interface timing:

- Is more accurate.
- Improves Quality of Results (QoR) when the final design is assembled.

Providing interface logic:

- Requires additional design time.
- Is preferred over the proxy logic method.
- Creates accurate interface timing to other partitions, giving more predictable results during assembly.

Black Box Usage

ISE Design Suite supports black box partitions from synthesis through implementation.

When using the XST incremental flow:

- A PXML file is used to define partitions.
- A partition can be added to a black box module.

Only a module or component declaration is needed to identify port widths and port direction.

When Black Boxes Are Supported

Black boxes are supported for implementation as long as the black box instance is also a partition, as defined by the PXML file. This can be useful when using the following:

- Team Design methodology
Team member blocks are not yet defined, or are not readily available.
See [Chapter 7, Team Design Flows](#).
- Memory reduction scheme
Multiple, smaller NCD files are used to export individual partitions.
See [Managing Memory Usage on Large Designs](#) in this chapter.
- Serial Buildup methodology
Partitions are added one at a time, allowing the implementation tools to concentrate on smaller sections of the design. This is essentially a serial version of Team Design.
See [Chapter 7, Team Design Flows](#).

Warning Message

When running implementation with a black box partition, NgdBuild generates a warning message. See the following example.

```
WARNING:NgdBuild:1419 - Could not resolve Partition block 'top/u0'.
This might be legal if you are implementing the Partition as a blackbox. If it is not a
blackbox, you should check that the Partition's module file, 'u0.ngc' or 'u0.edf' (or
another valid EDIF extension, exists and is properly set up in a search path (see the -sd
option.
```

Partition Implementation Status

The Partition Implementation Status section of the Ngdbuild Report (.bld) also contains information about the black box module.

```
Partition Implementation Status
-----
Preserved Partitions:

Implemented Partitions:

Partition "/eth_aggregator":
Attribute STATE set to IMPLEMENT.

Partition "/top/u0" (Black Box Module):
Attribute STATE set to IMPLEMENT.
-----
```

Proxy Logic

NgdBuild inserts proxy logic (a LUT1) on the partition ports (except clock ports) to prevent the partition from being empty. Xilinx recommends eventually replacing this black box module with real logic for timing closure.

This proxy logic can be timed by using a FROM:TO constraint in conjunction with a TPSYNC or PPS time group.

Depending on the design, these constraints can involve some or all of the following constraint examples.

```
TIMESPEC TS_FFS2PPS = FROM FFS TO PPS 3 ns;
TIMESPEC TS_PPS2FFS = FROM PPS TO FFS 3 ns;
TIMESPEC TS_PPS2PPS = FROM PPS TO PPS 3 ns;
```

These constraints can also include:

- Constraints TO or FROM other synchronous endpoints such as block RAM or I/O logic.
- Partition-specific versions of these constraints in which specific PPS time groups are created per partition.

```
TIMEGRP "PPS_TM1" = PPS(u1/*);
TIMESPEC TS_FFS2PPS_TM1 = FROM FFS TO PPS_TM1 3 ns;
```

This proxy logic:

- Is inserted only as a placeholder for real logic
- Is not part of the final design

When Black Boxes Are Not Supported

Black boxes are not supported in certain cases involving dedicated connections.

For example, if a partitioned module will eventually contain a high speed transceiver (GT) that connects to a dedicated I/O site in the top partition, this instance cannot be a black box.

To overcome this restriction, both end points of the dedicated connection (I/O and GT in this case) must exist in the same partition. You can either:

- Move the GT to the top partition, or
- Place the I/O buffer and pad inside the child partition.

Synthesizing and Implementing a Design with Black Boxes

When synthesizing and implementing a design with black boxes, some of the design is not present. This can cause unexpected results. Follow these additional design recommendations when using black boxes.

Instantiate Global Clock Buffers at the Top Level

Instantiate global clock buffers at the top level. Do not allow the synthesis tool to infer them. Failing to instantiate global clock buffers at the top level can result in no global buffers, or multiple global buffers being placed on the clock net.

Do Not Instantiate I/O buffers in Lower Level Partitions

Do not instantiate I/O buffers in lower level partitions. Instantiating I/O buffers in lower level partitions can result in multiple I/O buffers on a net, if buffers are also inferred in the top partition.

If you cannot follow these recommendation, use **BUFFER_TYPE=NONE** to control when buffers (global or I/O) are inferred.

For more information on **BUFFER_TYPE**, see:

- *XST User Guide for Virtex®-4, Virtex-5, Spartan®-3,, and Newer CPLD Devices (UG627)*, cited in [Appendix A, Additional Resources](#).
- *XST User Guide for Virtex-6, Spartan-6, and 7 Series Devices (UG687)*, cited in [Appendix A, Additional Resources](#).

Partition Context Rules

The term *context* refers to the logic surrounding the partition.

If a partition is implemented in one context, and that partition is then imported into a design with a different context, an error may result.

When Context Changes Are Allowed

In general, a context change is valid when using general routing for both the implementation and import runs of the partition. Example:

The partition being implemented has a register that is connected to another register in the parent partition during the implementation run.

During an import run, the register in the imported partition is connected to a LUT from the parent partition. There are no placement or routing restrictions between these two contexts.

When Context Changes Are Not Allowed

Context changes are not allowed when:

- Logic within the partition communicates with logic outside the partition, and
- General routing is not used.

Re-Implementing the Child Partition

In the examples below, the context has changed in such a way that the child partition must be re-implemented when it contains any of the following.

Generic Register

Generic register with an **IOB=FORCE** attribute driven by an IBUF from the parent partition.

The flip-flop is packed into the IOB. In the import run, the parent partition drives this register with some other logic (LUT for example) and the **IOB=FORCE** is removed.

Clocking Module

Clocking module such as a DCM_ADV in which CLKIN is driven from the parent partition by a PLL_ADV.

In the import run, the DCM_ADV is driven by something other than a PLL. This can also be caused by changing the driver of CLKIN in the parent partition from an IBUF (such as IBUFG or IBUFGDS) to something other than an IBUF (such as IBUFG or IBUFGDS).

ISERDES Block

ISERDES block driven by an IODELAY block in the parent partition.

In the import run, the ISERDES is driven by something other than an IODELAY block.

Block With a Dedicated Connection

Block with a dedicated connection (RX/TX pins of a GT block) to logic in the parent partition (IPAD/OPAD).

In the import run, the RX/TX pins are driven by something other than the dedicated IPAD/OPAD connections. Xilinx recommends keeping blocks and their dedicated connection in the same partition. Move the GT block to the parent partition, or move the I/O PADS into the child partition.

Design Considerations

Decide whether to use a Hierarchical Design (HD) flow at the *beginning* of design planning, not *after* a design has begun to yield inconsistent results or experience problems with timing closure.

To obtain the full benefit of an HD flow, take into account:

- The logical and physical layout of the design
- Hardware Design Language (HDL) coding guidelines
- The use of floorplanning constraints

Optimization Limitations

The following optimization limitations are inherent to the insulation created by partitions:

- [No Optimization Across Partition Boundaries](#)
- [Evaluation of Constants on Partition Inputs](#)
- [No Optimization of Unconnected Partition Outputs](#)
- [Logic From One Partition Cannot be Packed With Logic From Another Partition](#)

If even a single partition is added to a design, every instance in the design becomes part of a partition. Instances not specified as their own partition become part of the top partition.

No Optimization Across Partition Boundaries

There is no optimization across partition boundaries. This limitation includes optimization between:

- A parent and child partition
- Two child partitions

As compared to a flat design, this limitation can affect:

- Timing
- Utilization
- Power consumption

Examples of these optimization limitations include:

- Combinatorial logic from one partition cannot be optimized or combined with combinatorial logic from another partition.
- There is no resource sharing among partitions.

If common logic between multiple instances is to be optimized and shared, the logic must reside in the same partition.

In some cases, a specific sequence of logic allows the tool a more optimal design by taking advantage of specific hardware features.

- A block RAM connected directly to a flip-flop can be combined to use a register dedicated to the block RAM.
- A DSP connected to a flip-flop can pull the flip-flop into the DSP to create a faster pipelined DSP. If a partition boundary exists between these elements, this performance optimization cannot occur.

These examples cannot occur if the two elements do not reside within the same partition.

Evaluation of Constants on Partition Inputs

If inputs to a partition are tied to a constant value in order to guide optimization, the constant cannot be pushed across the partition boundary. No optimization occurs. This can occur when a constant is used to enable or disable a specific feature in a core or module.

Xilinx® does not recommend controlling logic in a module by means of extraneous ports. Xilinx recommends instead:

- Use parameters or attributes, or
- Include a package file.

No Optimization of Unconnected Partition Outputs

There is no optimization of unconnected partition outputs. If the output of a partition does not drive any other element, the source logic is not optimized as it is in a flat flow.

Logic From One Partition Cannot be Packed With Logic From Another Partition

Logic from one partition cannot be packed with logic from another partition. This might affect utilization if the FF-to-LUT ratio highly favors one or the other. If the combinatorial logic inside a partition drives an output that is eventually an FF, the LUT cannot be packed with an FF.

Limitations on Instances Used for Partitions

Instances are not supported for partitions in which:

- The module or entity is not defined in its own HDL file.
- The instance name can change (that is, names based on parameters or generate statements).

Active-Low Control Sets

Note: The following discussion uses a reset as an example, but the same principles apply to clock enables.

There are no local inverters on control pins (resets or clock enables).

Designs Without Partitions

If a design without partitions uses active-Low resets, use a LUT to invert the signal.

- Active-Low resets
One or more LUTs are inferred. These can be combined into a single LUT and pushed into the I/O elements. The LUT goes away.
- Mix of high and low resets
The LUT inverters can be combined into one LUT that remains in the design. This has minimal impact on routing and timing of the reset net. The LUT output can still be placed on global resources.

Designs With Partitions

In a design that uses active-Low resets inside a partition, inverters:

- Can be inferred inside the partition.
- Cannot be pulled out of the partitions.
- Cannot be combined with other inverters in the parent hierarchy.

In this case:

- The reset cannot be placed on global resources.
- There may be poor reset timing and routing issues if the design is already congested.

To avoid this, do not use active-Low control signals. This might not be possible, as, for example, when using an IP core with an AXI interface. In this case, Xilinx recommends that you:

- Assign the active-Low reset to a signal at the top level.
- Use the new signal everywhere in the design.

Example:

```
reset_n <= !reset;
```

- Use **reset_n** for all cases.
- Do not use any further **!reset** assignments on signals or ports.

This ensures that:

- Only LUT is inferred for the reset net for the whole design.
- There are minimal effects on design performance.

Using BoundaryOpt to Optimize IP Cores

Use the **BoundaryOpt** attribute in partitions to optimize IP cores.

For more information on **BoundaryOpt**, see:

- [Chapter 4, Command Line Partition Flow](#)
- [Chapter 5, PlanAhead Tool Partition Flow](#)

BoundaryOpt Effects

The **BoundaryOpt** attribute:

- Softens the partition interface.
- Allows some optimization of:
 - Input and output constants, and
 - Unconnected outputs of a partition.

BoundaryOpt Limitations

There are limitations to **BoundaryOpt**.

Modules with No RTL Access

Use **BoundaryOpt** *only* on modules with no Register Transfer Level (RTL) access, such as IP cores. Modules with RTL access should resolve these interface issues in the HDL code.

Setting BoundaryOpt on a Partition During Implementation

Setting **BoundaryOpt** on a partition during implementation might change the partition interface. For example, partition ports might be optimized away.

If the parent partition is then modified to connect logic to one of these optimized ports:

- The partition interface no longer matches the exported data from the previous implementation run.
- The exported data is lost.
- Both parent and child partitions must be re-implemented.

This can be summarized in two general rules:

- The context of the partition interface must remain the same for each run. **BoundaryOpt** adds additional cases in which this can be violated, for example, ports being optimized away.
- The **BoundaryOpt** value must remain consistent for each run.

Optimization Limitations

BoundaryOpt also has limitations on what can be optimized. The following figures illustrate scenarios that are, or are not, optimized with **BoundaryOpt**.

Constant Pushing

In [Figure 2-1, Constant Pushing](#), **BoundaryOpt** pushes constants across one partition boundary only. This removes the port from the partition interface. The route through nets is not optimized.

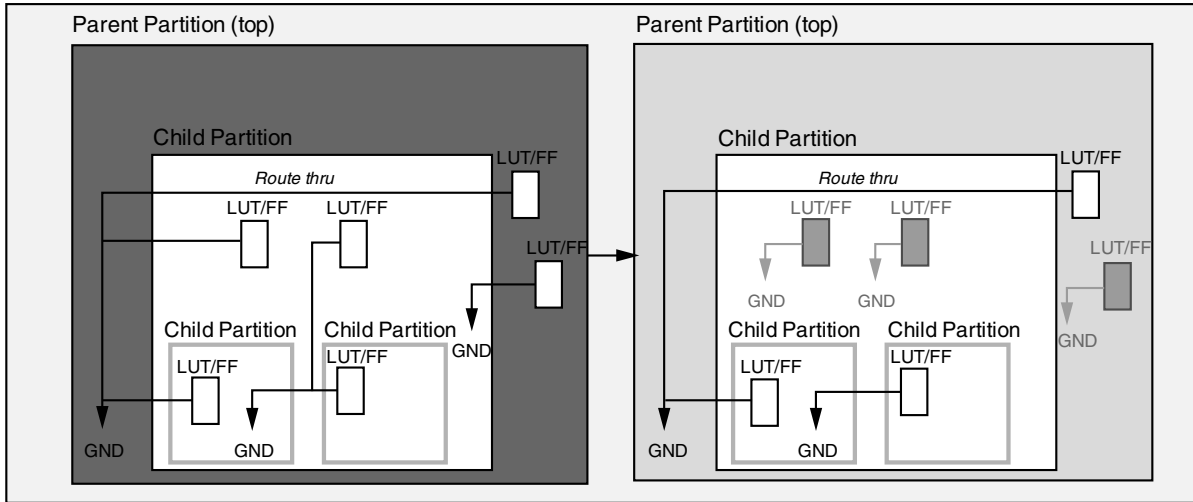

X12065

Figure 2-1: Constant Pushing

Unused Outputs

In [Figure 2-2, Unused Outputs](#), **BoundaryOpt** disconnects unused partition outputs allowing optimization to occur. This removes the port from the partition interface.

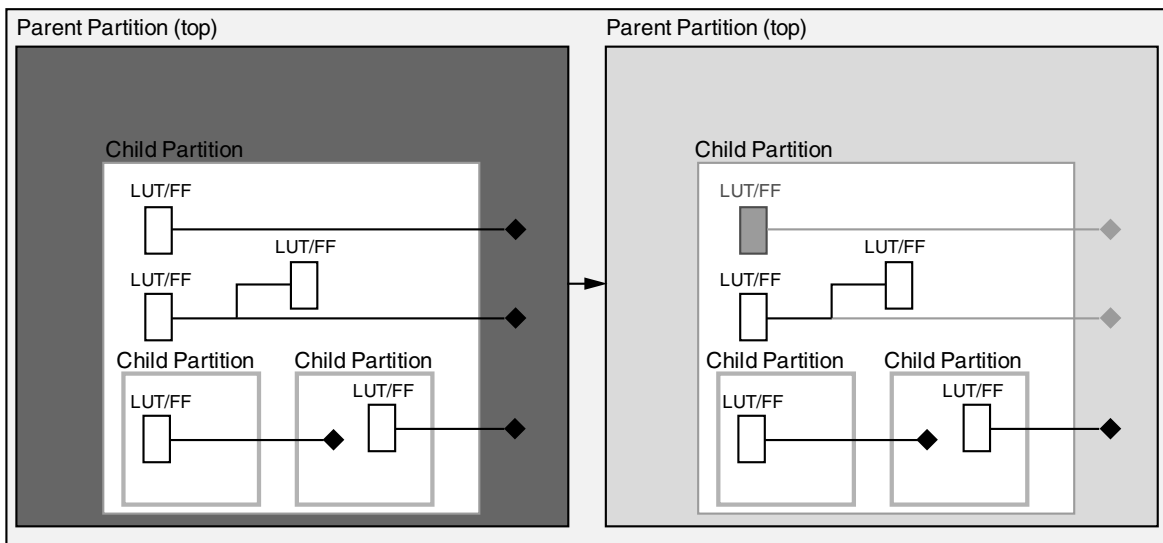

X12066

Figure 2-2: Unused Outputs

BoundaryOpt Values

BoundaryOpt values are:

- **all**
- **none**

The value set on a partition is shown in the Partition Summary section of the Map Report.

Architecting the Design

When implementing a design using a *flat flow*, synthesis and implementation tools can optimize the design for speed and area as a whole. Because the tools can optimize across hierarchical boundaries, the logical layout of the design is not as critical.

When implementing a design using an *HD flow*, partitions act as an optimization barrier in order to isolate the logic. This can dramatically impact the design. See the following figure as an example.

Sample Design Hierarchy

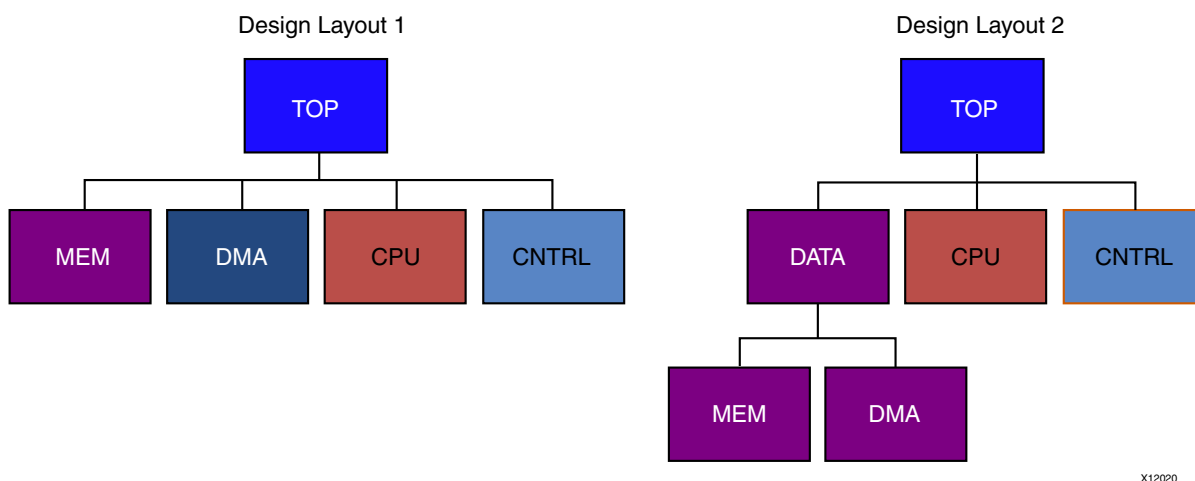

X12020

Figure 2-3: Sample Design Hierarchy

Optimization in Design Layout 1

In Design Layout 1, modules **MEM** and **DMA** are at the same hierarchical level.

If partitions are added to all modules under **TOP**, there can be no optimization between **MEM** and **DMA**.

If these two modules contain substantial related logic:

- In a *flat flow*, the modules benefit from optimization.
- In an *HD flow*, there is no optimization. This might lead to increased utilization and poor timing results.

Optimization in Design Layout 2

In Design Layout 2, modules with shared logic are grouped together under one partition (**DATA**). The same optimization for **MEM** and **DMA** that was not possible in a flat flow can be achieved in an HD flow by redefining the hierarchy.

Achieving the Benefits of an HD Flow

Decide whether to use an HD flow *before* you architect the design, define module interfaces, and code the modules. Do not use an HD flow as a timing closure technique *after* timing issues arise in a flat flow.

The partition creates insulation for the module, which limits the ability of the tool to optimize across the boundary.

To achieve the benefits of an HD flow:

- [Register Input and Output Ports](#)
- [Do Not Use Nets Both Inside and Outside a Partition](#)
- [Manage High Fanout Nets](#)
- [Do Not Use Constants as Nets](#)
- [Do Not Use Unconnected Ports](#)
- [Place Dedicated Connections in the Same Partition](#)

Register Input and Output Ports

You *must* register inputs and outputs if possible.

Because no optimization occurs across the partition boundary, inputs and outputs can easily become timing bottlenecks.

Registering the inputs and outputs:

- Enables the tools to focus on paths internal to the partition.
- Allows true timing preservation on the module.

Nets that cross a partition boundary are *not* preserved unless *all* partitions connected to the net are imported. As a result, timing critical nets that cross this boundary might continue to cause violations in the partition even when imported. Registering the boundary nets prevents timing critical changes internal to the partition.

Do Not Use Nets Both Inside and Outside a Partition

Do not use nets both *inside* and *outside* a partition.

If nets must be used both in a partition, and as output ports:

- Duplicate the source of the nets.
- Use one net internally.
- Use the other net as the output port.

Manage High Fanout Nets

You must account for fanout on outputs of partitioned modules. If the output of a partition has a high fanout, and connects to multiple areas of the design, the driver might need to be replicated.

- In *flat flows*, this replication occurs automatically.
- In *HD flows*, you must replicate the driver by hand.

Do Not Use Constants as Nets

Do not use constants as nets.

Some netlist modules, such as IP cores, assume that the Map tool optimizes away unneeded portions of logic. This is generally achieved by tying core inputs to constants that either enable or disable certain logic.

This technique:

- Allows IP to be delivered as a netlist, while still allowing some customization.
- Does not work well with partitions because of the optimization boundary.

If a partition is added directly to an Electronic Data Interchange Format (EDIF) or NGC core for which the Map tool is expected to optimize logic based on constants on the ports, no logic optimization occurs. The results will not be ideal.

If you must place a partition on a core that exhibits this behavior:

- Add an HDL wrapper to wrap the EDIF or NGC core.
- Place the partition on the wrapper.

The port list of the HDL wrapper should contain only the necessary I/O connecting the IP core to the rest of the design. Constant assignments can remain in the wrapper logic. With the partition defined a level above the IP core, the Map tool can trace the constant into the core and perform any necessary optimization.

Do Not Use Unconnected Ports

Do not use unconnected ports.

Unconnected outputs have a similar effect on optimization. If a partition output is unconnected, the Map tool cannot optimize the driver associated with this source-less net as it can in a flat flow.

If this logic cannot be optimized in the HDL code, adding a wrapper around the partition:

- Moves the partition boundary.
- Allows the Map tool to optimize the logic.

A partition output can cause errors if it:

- Is not driven by logic, and
- Connects to logic outside the partition.

The implementation tools cannot see that the partition output is not driven, and route a partial net. This causes Design Rules Check (DRC) errors during the BitGen process. Remove any unnecessary partition ports and re-implement the partition.

Place Dedicated Connections in the Same Partition

Place dedicated connections in the same partition.

Some elements in the FPGA device work together to provide specific functions, or to provide dedicated connections for fast, low skew routing.

These elements cannot always be correctly configured if they are separated by a partition boundary. Place these instances in the same partition.

These elements are:

- OSERDES, IODELAY, and OBUFTDS
- OSERDES, ODDR, and OBUFTDS
- IDELAY and IDELAYCNTRL
- ISERDES, IDDR, and IBUFDS

Limitations on Preserving Routing Information

Not all routing information can be preserved.

A route that belongs to a partition might be rerouted when:

- The preservation level of the imported partition is set to **Placement** or **Synthesis** instead of **Routing**.
- An I/O buffer in a lower level partition is imported, and the associated pad is in the parent *implemented* partition.

Because this route is dedicated, it does not change even though it is not technically preserved.

- A flip-flop in a lower level partition is imported, and is connected to an I/O buffer in the parent *implemented* partition.

The route is dedicated and remains identical if the flip-flop is packed into the I/O logic. An **IOB=FORCE** or an **IOB=TRUE** constraint is necessary to allow the tools to pull the flip-flop across the partition boundary and pack it into the I/O Logic. If the flip-flop is packed into a slice, the routing is not preserved and timing cannot be guaranteed.

If the implementation tools cannot properly pack the flip-flop into the I/O logic:

- **IOB=FORCE** generates an error.
- **IOB=TRUE** generates a warning.
- A LUT in a lower level partition is imported, and is connected to an I/O buffer in the parent *implemented* partition. In this instance:
 - The LUT must be packed into slice logic.
 - The route is not dedicated.
 - Timing cannot be guaranteed
- A PWR or GND net exists in the design, and the top partition is implemented.

PWR and GND nets are always implemented or imported along with the top partition, even if the nets belong to a child partition.

Floorplanning Partitions

Note: This section specifically refers to using AREA_GROUP constraints.

Floorplanning is controlling the placement of a design through constraints.

Creating Slice Ranges on a CLB Boundary

Although there are no restrictions on using AREA_GROUP constraints in partitioned designs, Xilinx recommends creating slice ranges on a CLB boundary. Doing so maximizes the available resources for placement and routing.

To verify that a slice range was correctly aligned to a CLB boundary, check the XY coordinates of the constraint.

The range is on a CLB boundary if the XY coordinates:

- Start on an even number.
- End on an odd number.

Example: **x0y0** to **x3y9**

You can use the PlanAhead™ tool to:

- Create the AREA_GROUP constraints.
- Snap the constraints to CLB boundaries.

For more information on CLB and other blocks, see the Xilinx data sheets cited in [Appendix A, Additional Resources](#).

Keeping Logic in One Area

Floorplanning keeps all logic associated with a partition in one area of the device.

Keeping logic in one area of the device:

- Creates a region for placing and routing each partition.
- Minimizes the risk of routing conflicts during import.
- Reserves other parts of the device for additional logic that will be included later.

Using the Command Line Tools

Although the PlanAhead tool supports partitions, you can also run the partitioned design using the command line tools.

You can use the PlanAhead tool to:

- Set up the partitions.
- Floorplan the design.
- Create the PXML file.

See [Chapter 4, Command Line Partition Flow](#).

Design Preservation

While design preservation partitions do not *require* an AREA_GROUP constraint, floorplanning some designs with AREA_GROUP can:

- Improve runtime and timing results.
- Reduce placement and routing conflicts during import.

Team Design Flow Requirements

- Each Team Member partition must have an associated ranged AREA_GROUP constraint to contain the required logic for that partition.

If the logic from a Team Member partition must be located outside the AREA_GROUP RANGE, move that logic to the top partition to avoid placement conflicts during assembly.

- No Team Member AREA_GROUP RANGE is allowed to overlap with any other Team Member AREA_GROUP RANGE.

This includes AREA_GROUP RANGE constraints belonging to the top partition.

- Each Team Member partition must belong to:
 - A single AREA_GROUP, or
 - A child of that AREA_GROUP
- Do not group logic from one Team Member with logic from another Team Member in an AREA_GROUP constraint. Relocate any logic critical to the interface timing between the two Team Member partitions to the top partition. This allows the logic to be placed across both Team Member partitions.

Partitioning Processor Systems

When placing a partition on an EDK processor system, the BMM file must be provided at NGDBuild in both the initial run and in any subsequent import runs.

Synthesis Partition Flow

In a Hierarchical Design (HD) flow, each partition is synthesized individually.

Individual synthesis prevents a design change in one area from causing different synthesis results in another area.

The available synthesis partition flows are:

- [Incremental Synthesis Partition Flow](#)
- [Bottom-Up Synthesis Partition Flow](#)

Incremental Synthesis Partition Flow

Most third-party synthesis tools support incremental synthesis.

During incremental synthesis:

- Register Transfer Level (RTL) modules can be marked as partitions.
- Each partition is synthesized separately with hard hierarchical boundaries.
- A Hardware Design Language (HDL) change in one module does not affect another module.
- The tools determine which modules or instances must be re-synthesized because of HDL or constraint changes.

Supported Incremental Synthesis Partition Flows

The supported incremental synthesis partition flows are:

- [Synplify Pro and Synplify Premier](#)
Uses compile points.
- [Mentor Precision](#)
Uses attributes in HDL to specify partitions.

Advantages of Incremental Synthesis Partition Flow

The incremental synthesis partition flow has the following advantages:

- No need to create separate synthesis project files for each partition.
- Easier transition from a flat synthesis flow.
- The synthesis tool determines which modules are re-synthesized because of HDL code changes and timing constraint changes.

Bottom-Up Synthesis Partition Flow

In the bottom-up synthesis partition flow:

- Each partition has a separate synthesis project and resulting netlist.
- The designer decides which synthesis projects to run because of HDL code or synthesis constraint changes.
- The top level is synthesized by using black boxes for the lower level modules.
- The lower level modules are synthesized without inferring I/O or clock buffers.

Supported Bottom-Up Synthesis Partition Flows

The bottom-up synthesis partition flow is supported by:

- Third-party synthesis tools
- [Xilinx Synthesis Technology \(XST\)](#)
XST uses attributes in HDL to specify partitions.

Advantages of Bottom-Up Synthesis Partition Flows

The bottom-up synthesis partition flow has the following advantages:

- All Team Members have their own synthesis project.
Several Team Members can work on the same design during synthesis.
- Team Members control which instances are re-synthesized.
 - The Team Member determines which project is re-synthesized, making it easier to determine which instances are re-synthesized.
 - Each netlist has a unique time stamp.

Synthesis Tools

Synthesis tools include:

- [Synplify Pro and Synplify Premier](#)
- [Mentor Precision](#)
- [Xilinx Synthesis Technology \(XST\)](#)

Synplify Pro and Synplify Premier

There are two ways to use Synplify Pro and Synplify Premier for partitions:

- [Synplify Pro and Synplify Premier Bottom-Up Synthesis Partition Flow](#)
- [Synplify Pro and Synplify Premier Incremental Synthesis Partition Flow](#)

Synplify Pro and Synplify Premier Bottom-Up Synthesis Partition Flow

In the Synplify Pro and Synplify Premier bottom-up flow, each instance has a corresponding Synplify project file. Do not infer IOB components or global clock buffers in the lower level project files.

- To turn off I/O insertion in the project file, use:

```
set_option disable_io_insertion 1
```
- To use **syn_noclockbuf** to turn off clock buffer usage:
 - Insert the following in the Synplify Design Constraints (SDC) file:

```
define_attribute { clock_port } syn_noclockbuf 0
define_global_attribute syn_noclockbuf 0
```

OR
 - Insert **syn_noclockbuf** directly into the HDL code.

See the Synplify documentation.

Synplify Pro and Synplify Premier Incremental Synthesis Partition Flow

Synplify Pro and Synplify Premier support the incremental synthesis partition flow. The incremental synthesis partition flow uses compile points to break down the design into smaller synthesis units.

Use the locked mode to create a solid boundary with no logic moving in or out of the compile point. The soft and hard modes allow optimizations across boundaries, which are not supported.

Any netlist changes to a partition require that a partition be implemented. The NGDBuild tool issues an error if the netlist does not match the imported partition.

Following is an example compile point in the SDC file:

```
define_compile_point {v:controller} -type {locked} -cpfile {}
```

Synplify Synthesis Report

Use Synplify to create and modify any compile points in the SDC file. The Synthesis Report displays the status of each compile point.

```
Summary of Compile Points
Name Status Reason
-----
controller Unchanged -
elevator_car Remapped Design changed
express_car Remapped Design changed
top Remapped Design changed
=====
```

Running the Xilinx Implementation Tools (Synplify)

Use any of the following after synthesis to run the Xilinx® implementation tools:

- [ISE® Design Suite Command Line Flow \(Synplify\)](#)
- [PlanAhead Tool Flow \(Synplify\)](#)
- [Synplify Cockpit \(Synplify\)](#)

ISE® Design Suite Command Line Flow (Synplify)

Synplify runs a Tcl command to create an updated PXML file for use with the Xilinx implementation tools.

See [Chapter 4, Command Line Partition Flow](#).

PlanAhead Tool Flow (Synplify)

The PlanAhead™ design tool flow imports:

- The synthesis netlists
- The PXML file generated from Synplify (optional)

You can also redefine the partitions manually inside the PlanAhead tool.

See [Chapter 5, PlanAhead Tool Partition Flow](#).

Synplify Cockpit (Synplify)

Run the Xilinx implementation tools from within the Synplify cockpit.

See the Synplify Pro and Synplify Premier documentation at <http://www.synopsys.com>.

Mentor Precision

The Mentor Precision synthesis tool supports HD flows. The most common flow is the partitions-based incremental flow. In this flow, you can specify partitions using attributes. These can be set on a module or instance.

Precision Synthesis Report

```
Verilog Module:
module my_block( input clk; ...) /* synthesis incr_partition */;
Verilog Instance:
my_block my_block_inst( .clk(clk), ... .data_out(data_out) ); // synthesis attribute
my_block_inst
incr_partition true
VHDL Module:
entity my_block is port( clk: in std_logic; ...); attribute incr_partition : boolean;
attribute incr_partition
of my_block : entity is true; end entity my_block;
VHDL Instance:
component my_block is port( ... end component; ... attribute incr_partition : boolean;
attribute
incr_partition of my_block_inst : label is true; ... my_block_inst
```

The Synthesis Report shows whether or not a partition is being optimized based on the partition state.

```
[16027]: Incremental: Skipping Optimize for <...>.fifo_16_64.rtl_unfold_0
[16027]: Incremental: Skipping Optimize for <...>.fir_filter.rtl_unfold_0
[15002]: Optimizing design <...>.fsm.rtl_unfold_0
[16027]: Incremental: Skipping Optimize for <...>.fir_top.rtl
```

Running the Xilinx Implementation Tools (Precision)

Use any of the following after synthesis to run the Xilinx® implementation tools:

- [ISE Design Suite Command Line Flow \(Precision\)](#)
- [PlanAhead Tool Flow \(Precision\)](#)
- [Mentor Precision \(Precision\)](#)

ISE Design Suite Command Line Flow (Precision)

Click **Place & Route** to create a PXML file for use with the Xilinx implementation tools.

See [Chapter 4, Command Line Partition Flow](#).

PlanAhead Tool Flow (Precision)

The PlanAhead tool flow imports the synthesis netlists. The design partitions are defined inside the PlanAhead tool.

See [Chapter 5, PlanAhead Tool Partition Flow](#).

Mentor Precision (Precision)

Click **Place & Route** to run the ISE® Design Suite implementation tools automatically.

See the application note on the Mentor Graphics SupportNet site at <http://supportnet.mentor.com>.

Xilinx Synthesis Technology (XST)

The Xilinx Synthesis Technology (XST) supports:

- [XST Bottom-Up Synthesis Partition Flow](#)
- [XST Top-Down Incremental Flow](#)

XST Bottom-Up Synthesis Partition Flow

In the XST bottom-up synthesis partition flow, each instance used as a partition (including the top partition) has its own synthesis project file.

Caution! Do not infer IOB components or global clock buffers in lower level partitions if they are contained in the top partition.

Use the following option in the XST file to prevent I/O components from being inferred:

-iobuf NO

If IOB components are used in a lower level partition, you must prevent an additional IOB from being inferred in the top level. To turn off IOB insertion:

- For the *entire top level*, use the **-iobuf** option.
- For *individual signals*, put a **BUFFER_TYPE=NONE** attribute on the individual signal names.

The **BUFFER_TYPE=NONE** attribute can also be used to prevent global buffers (BUFG) from being inferred in the top level when a lower level partition has a BUFG instantiated.

For more information on how to set the **BUFFER_TYPE** attribute, and how to run XST in command line mode, see:

- *XST User Guide for Virtex-4, Virtex-5, Spartan-3, and Newer CPLD Devices (UG627)*, cited in [Appendix A, Additional Resources](#)
- *XST User Guide for Virtex-6, Spartan-6, and 7 Series Devices (UG687)*, cited in [Appendix A, Additional Resources](#)

XST Top-Down Incremental Flow

The XST top-down incremental flow:

- Was new in the ISE Design Suite 13.1 release.
- Supports Virtex®-6, Spartan®-6, and Xilinx 7 series FPGA devices only.
- Does not support Virtex-4, Virtex-5, or Spartan-3 devices.
- Allows easier setup than bottom-up flow.
- Supports both the command line and the PlanAhead tool.
- Allows you to define partitions on hierarchical instances. XST writes out individual NGC files for each partition.

PXML File

The partitions are defined and controlled by a PXML file named `xpartition.pxml`.

- For the command line, the PXML file can be the same or a different PXML file than the PXML file used for implementation.
- The PlanAhead tool manages the PXML files.

For more information on using this capability for a particular methodology such as Design Preservation or Team Design, see the other chapters of this document.

XST reads a PXML file as follows:

- If the PXML file exists in the *current working directory*, XST reads it in.
- If the PXML file exists in a *different directory* (such as an implementation directory), use the **-partition_file** switch to point XST to the file.

This switch can specify one or more remote locations to search for a PXML file.

Importing Unchanged Partitions

Because the XST incremental flow supports importing unchanged partitions, some partitions may be set to **Import** and have an **ImportLocation** attribute defined. If the **ImportLocation** is a relative path, the path must be relative to the PXML file, not relative to the present working directory, if different.

A partition set to *import* in synthesis may need to be set to *implement* for implementation if the exported implementation data:

- Is out of date, or
- Does not exist.

In this case, it might be easier to use separate PXML files for synthesis and implementation.

In order to import previous synthesis results, the results must be exported to another location. This prevents the results from being overwritten in the next synthesis run. The

exported synthesis results must contain the NGC and HDX files for the partition that is being imported.

Command Line Partition Flow

The ISE® Design Suite command line partition flow:

- Uses partitions on a post-synthesis design.
- Is command line driven.
- Uses the Xilinx® implementation tools.

Xilinx Implementation Tools

The ISE Design Suite command line partition flow uses the following Xilinx implementation tools:

- NGDBuild
- Map
- PAR

The Xilinx implementation tools look for the PXML file in the current working directory. The current working directory is the directory from which the implementation tools are being run.

The Xilinx implementation tools use the PXML file to determine:

- The partitions defined in the design
- The partition states

Creating a PXML File

The PXML file:

- Contains partition definitions.
- Is case-sensitive.
- Must be named `xpartition.pxml`.
- Must be consistently present for all implementation tools:
 - NGDBuild
 - Map
 - PAR

The PXML file can be created:

- Manually in a text editor.

A template for manually creating a PXML file is located in the install directory at:

```
<Xilinx_13_directory>/PlanAhead/testcases/templates/xpartition.pxml
```

- In a design analysis tool, such as the PlanAhead™ tool.

To use the PlanAhead tool to create a PXML file, see [Exporting PXML Files](#) in [Chapter 5, PlanAhead Tool Partition Flow](#).

If you create the PXML file by hand, or with a third-party synthesis tool, see [Running Implementation](#) in this chapter.

The top level module of the design must be defined as a partition in addition to any optional lower level partitions. Child or nested partitions are supported.

The implementation tools recognize the PXML file when it is located in the current working directory.

Sample PXML File

```
<?xml version="1.0" encoding="UTF-8" ?>

<Project FileVersion="1.2" Name="Example" ProjectVersion="2.0">
  <Partition Name="/top" State="implement" ImportLocation="NONE">
    <Partition Name="/top/module_A" State="import" ImportLocation="/home/user/Example/
export" Preserve="routing">
      </Partition>
    <Partition Name="/top/module_B" State="import" ImportLocation="../export"
Preserve="routing">
      </Partition>
    <Partition Name="/top/module_C" State="implement" ImportLocation="../export"
Preserve="placement">
      </Partition>
    </Partition>
  </Project>
```

PXML Attributes and Values

The following tables describe the attributes and values used in the sample PXML file.

Table 4-1: PXML Attribute and Values for *Project* Definition

Attribute Name	Value	Description
FileVersion	1.2	Used for internal purposes. Do <i>not</i> change this value
Name	<i>Project_Name</i>	<i>Project_Name</i> is user defined.
ProjectVersion	2.0	Used for internal purposes. Do <i>not</i> change this value

Table 4-2: PXML Attributes and Values for *Partition* Definition

Attribute Name	Value	Description
Name	<i>Partition_Name</i>	Hierarchical instance name of module in which the partition should be applied.
State	<i>implement</i>	Partition is implemented from scratch.
	<i>import</i>	Partition is imported and preserved according to the level set by Preserve .
	<i>auto</i>	<i>imports</i> partitions that <i>have not</i> logically changed and <i>implements</i> partitions that <i>have</i> logically changed. Requires the ImportLocation attribute to be defined. Command line only.
ImportLocation	<i>Path</i>	Ignored if State does not equal <i>import</i> . Path can be relative or absolute, but the location specified must contain a valid <i>export</i> directory when State=import . NONE is a predefined keyword for no import directory.
ImportTag	<i>Partition_Name</i>	Allows a partition to be imported into a different level of hierarchy than it was initially implemented in. Set the value to the hierarchical instance name of the partition when it was implemented.
Preserve	<i>routing</i>	100% placement and routing is preserved. This is the default for top partition.
	<i>placement</i>	Placement is preserved, and routing can be modified.
	<i>synthesis</i>	Placement and routing can be modified.
	<i>inherit</i>	Inherit value from the parent partition. This is the default for all partitions except the top partition.
BoundaryOpt	<i>all</i>	Enables the implementation tools to do optimization on partition ports connected to constants as well as unused partition ports.
	<i>none</i>	Normal partition optimization rules apply. Optimization allowed only within partition boundary. This is the default value.

Running Implementation

Once the PXML file has been created, you can run the Xilinx implementation tools in command line mode or batch mode.

Following is a sample basic script:

```
ngdbuild -uc design.ucf design.edn design.ngd
map -w design.ngd -o design_map.ncd design.pcf
par -w design_map.ncd design.ncd design.pcf
```

The netlist specified in the NGDBuild command must *not* be the output of a flat synthesis run. The synthesis project must be created with partitions in mind when it is set up and run. See [Chapter 3, Synthesis Partition Flow](#).

Implementation Tool Reports

Review the implementation tool reports to verify that:

- The tools recognized the PXML file.
- The partition states are set correctly.

NGDBuild Report Example

For example, the NGDBuild Report (.bld) contains a section displaying the Partition Implementation Status. The Map Report and the PAR Report contain similar sections.

```
-----
Partition Implementation Status
-----
Preserved Partitions:

Implemented Partitions:

Partition "/top":
Attribute STATE set to IMPLEMENT.

Partition "/top/Control_Module":
Attribute STATE set to IMPLEMENT.

Partition "/top/Express_Car":
Attribute STATE set to IMPLEMENT.

Partition "/top/Main_Car":
Attribute STATE set to IMPLEMENT.

Partition "/top/Tracking_Module":
```

Implementation Options Not Supported By Partitions

Partitions do not support the following implementation options:

- Global Optimization (**-global_opt**)
- SmartGuide™ technology (**-smartguide**)
- Power Optimization (**-power**)
- Multithreading (**-mt**)

Special Xilinx Environment Variables

Many special Xilinx environment variables (XIL_*) can significantly impact the implementation tools. These effects may vary from one ISE Design Suite release to the next.

Because Xilinx HD flows have not been tested with environment variables, Xilinx recommends removing all special Xilinx environment variables before running the tools.

Exporting Partitions

Export the partitions when you are satisfied with the implementation results. To export partitions, copy the implementation files to an export directory.

If a complete copy of the implementation directory is too large, use a script to copy only:

- [Required Files](#)
- [Optional Files](#)

Required Files

The required files are:

- [PREV Files](#)
- [PXML File](#)

PREV Files

The PREV (*_prev_*.*) files contain the previous implementation data required to import a partition. These files are created when a design is implemented with partitions.

In the examples below, the top level design was named **top**, which is included in some of the file names.

The PlanAhead tool promotes the following required PREV files:

- top_prev_built.ngd
- top_prev_mapped.ncd
- top_prev_mapped.ngm
- top_routed_prev_routed.ncd

PXML File

The PXML file must be included in order to verify that it is appropriate to import a partition. For example, if the PXML file does not contain the partition being imported, the PlanAhead tool generates an error.

Optional Files

The optional files are:

- [Report Files](#)
- [User Constraint File \(UCF\)](#)

Report Files

Saving report files is optional, but you may find it useful to preserve these files for later reference.

The PlanAhead tool promotes the following report files:

- NGDBuild (.bld)
- Map (.mrp and .map)
- PAR (.par)
- TRACE (.twr and .twx)

User Constraint File (UCF)

The User Constraint File (UCF) is optional.

These files are optional, but important. They document the options that were run when the design was implemented.

Caution! Do not to modify the files in the exported directory in any way. They become source files when imported in subsequent design runs.

Multiple partitions in a design are all exported. Think of the entire design as being exported, rather than a specific partition.

Updating Partition State to Import

Once the partition has been exported, update the PXML file to reflect the current state of the partitions. Use a text editor.

To *import* a partition that has been *exported*:

1. Set the partition state to *import*.
2. Set the **ImportLocation** attribute to the location of the exported partitions.

You can specify:

- A relative path, such as:
../export
- An absolute path, such as:
/home/user/Example/export

Iterative Design

Make any necessary design changes and re-synthesize. If synthesis modifies an exported partition, manually change the partition state from *import* to *implement* in the PXML file.

The NGDBuild tool issues an error if you attempt to import a partition that does not exactly match the partition from the import location.

```
ERROR:NgdBuild:1037 - The logic for imported partition '/top/Main_Car' using previous implementation './export/top_prev_built.ngd' has been modified.
```

A failure can occur if the partition source was modified, but the partition was not re-implemented and exported. The partition must be re-implemented and exported before it can be imported into the design.

Adding comments to the Hardware Design Language (HDL) code might result in small logic or naming changes in the netlist. The partition must be implemented on the next iteration.

A partition must be exported in order to be used in the next iteration if:

- The partition is imported with the preservation level set to anything other than routing, and
- The placement and routing are modified by the PAR tool.

Using SmartXplorer in Partitioned Designs

Use SmartXplorer to help meet timing in partitioned designs with tight timing requirements:

1. Run SmartXplorer on the completed partitioned portions of the design.
2. Use the standard implementation flow to implement other portions of the design that are changing.
3. Import the SmartXplorer results for the timing critical modules.

For more information on SmartXplorer, see the *Command Line Tools User Guide (UG688)*, cited in [Appendix A, Additional Resources](#).

Running SmartXplorer by Pointing to a Netlist or NGD File

You can run SmartXplorer by pointing to:

- A netlist file (EDIF or NGC), or
- An NGD file

The PXML file must be located in the same directory as the netlist file or the NGD file.

Because the PXML file is usually located in the same directory as the NGD file, Xilinx recommends that you:

1. Run NGDBuild first.
2. Launch SmartXplorer using the NGD file.

This process makes it unnecessary to copy the PXML file to a remote netlist directory.

SmartXplorer Directory Paths

When importing partitions from a SmartXplorer run, the import location in the PXML file must point to the directories created by SmartXplorer.

The directory path can be:

- Relative, such as:
../run2
- Absolute, such as:
/home/user/Example/run2

SmartXplorer Inputs

You can run SmartXplorer with either the top level netlist or the Native Generic Database (NGD) file as the input.

If the input is an NGD file:

- The NGD file must be created using the same PXML file used by the Map tool and the PAR tool.
If no PXML file was present when the NGDBuild tool was run, the Map tool and the PAR tool ignore the PXML file.
- SmartXplorer runs the Map tool and the PAR tool. The NGD file is one level up.
To import the SmartXplorer results, the `*prev_built.ngd` file one level up must be copied into the appropriate `runs` directory created by SmartXplorer before importing from that location.

Removing and Restoring Partitions

You can remove and restore partitions.

Removing Individual Partitions

To remove *individual* partitions:

1. Remove the references from the PXML file.
2. Set the state of the parent partition to *implement*.

Removing All Partitions

To remove *all* partitions and run a flat flow, rename or remove the PXML file from the implementation directory.

Restoring Partitions

To restore partitions:

1. When all partitions were removed, add the PXML file back to the implementation directory, or
2. When individual partitions were removed, add individual lines back to the PXML file defining the partitions.

You may still be able to import partitions that were removed and then added back in.

You can import the partitions only if:

- The input netlists have not been changed.
- The export directory still exists.

PlanAhead Tool Partition Flow

The PlanAhead™ tool supports both Register Transfer Level (RTL) projects and Netlist projects for partition-driven flows.

About the PlanAhead Tool Partition Flow

This section provides general information about the PlanAhead tool partition flow.

Add or Remove Partitions

Use the following views to add or remove partitions.

Table 5-1: Adding and Removing Partitions

Project	View
RTL	RTL Design
Netlist	Netlist Design

RTL-Based Projects

RTL-based projects:

- Support Virtex®-6, Spartan®-6, and Xilinx® 7 series FPGA devices only.
- Use the incremental capabilities of Xilinx Synthesis Technology (XST) to:
 - Synthesize the design.
 - Generate individual NGC files for each partition.

If you prefer another synthesis vendor, or XST bottom-up synthesis, you must:

- Run synthesis outside the PlanAhead tool.
- Use a PlanAhead tool Netlist project for implementation.

For Netlist projects, define a partition only on a level of hierarchy that has its own netlist.

Flat Netlist Projects

You can create a non-HD (flat) Netlist project in the PlanAhead tool, and add partitions to the levels of hierarchy of the project.

Because synthesis produces only a single netlist, changing one part of the design will likely affect other parts of the design. This negates the ability to import promoted results.

A flat, global optimization synthesis flow is not supported.

For more information on setting up synthesis projects for partitions, see [Chapter 3, Synthesis Partition Flow](#).

Creating a New Project

To create a new project in the PlanAhead tool:

1. On the Getting Started page, select **Create New Project**.
The New Project wizard guides you through the steps of creating a new PlanAhead project.
2. On the Design Source page, choose either:
 - a. An RTL project, or
 - b. A Netlist project.
3. Continue through the wizard.
4. Specify the following:
 - a. Sources
 - b. User Constraint Files (UCF)
5. Click **Finish**.

Creating Partitions

To create partitions in the PlanAhead tool:

1. Load the RTL Design view or the Netlist Design view in the Flow Navigator.
2. Select the RTL Netlist tab or the Netlist tab to view the design hierarchy.
3. Select the module instances to be partitioned.
4. Right-click and select **Set Partition**.
Select only instances that have been designed and synthesized with partitions in mind.

Importing PXML Files

Synplify can generate a PXML file in the Synplify compile points flow. See the Synplify documentation relating to `sxm12pxml`.

The values in the `sxm12pxml` file can be imported into the PlanAhead tool to define the partitions for you. If any partitions are already defined, the option is grayed out.

To import a PXML file:

1. Load the RTL Design view or the Netlist Design view in the Flow Navigator.
2. Select the Netlist tab to view the design hierarchy.
3. In the Netlist window, right-click and select **Import Partition Settings**.

Exporting PXML Files

You can use the PlanAhead tool to create a PXML file for use in the ISE® Design Suite command line flow.

To create a PXML file:

1. Load the RTL Design view (if using an RTL project), or the Netlist Design view (if using a Netlist project).
2. Click the Netlist tab.
3. Select the module instances to be marked as partitions.
4. Right-click and select **Set Partition**.
5. From the Synthesize button or the Implement button pull-down list, select **Implementation Settings**.
6. In the Implementation Settings dialog box, click the button next to **Current launch options**.
7. In the Launch Options dialog box, select **Generate scripts only**.
8. Click **OK**.
9. Click **Run**.

The PXML file:

- Is generated in the `<project_name>.runs/impl_1` directory.
- Can be copied to the location from which the ISE® Design Suite command line flow is run.

For more information on running HD flows, see [PlanAhead Tool Design Preservation Flow](#) in [Chapter 6, Design Preservation Flows](#).

For more information on how to use the PlanAhead tool, see the *PlanAhead User Guide (UG632)* cited in [Appendix A, Additional Resources](#).

Setting the BoundaryOpt Attribute

The BoundaryOpt attribute enables some optimization on a partition boundary. This optimization affects implementation results only. There is no XST support.

To add the BoundaryOpt attribute on a partition:

1. Select the partition in the Netlist view.
2. In the Instance Properties view, select the Partition tab.
3. Check the Boundary Optimization box.
4. Click **Apply**.

See [Chapter 2, Design Considerations](#).

Setting the ImportTag Attribute

The ImportTag attribute allows a partition defined in one hierarchy to be imported into a new hierarchy. This is supported for:

- The XST incremental flow
- The implementation tools

Setting the ImportTag Attribute on a Partition

To set the ImportTag attribute on a partition:

1. Select the partition in the (RTL) Netlist view.
2. In the Instance Properties view, select the Partition tab.
3. In the ImportTag text field, enter the hierarchical name of the partition when it was implemented.
4. Click Apply.

Setting the ImportTag Attribute from the Tcl Console

To set the ImportTag attribute from the Tcl Console, enter the following Tcl command:

```
set_property HD_IMPORT_TAG "<original_partition_name>" [get_cells "<current_instance_name*>"]
```

To remove the ImportTag attribute, repeat this command, but leave the value empty. Enter the following Tcl command:

```
set_property HD_IMPORT_TAG "" [get_cells "<current_instance_name*>"]
```

The value of **get_cells**:

- Is the instance name, not the partition name.
- Includes the top level module or entity name.

See [Chapter 1, Partitions](#).

Floorplanning Partitions

To decide if a partition should be floorplanned, see [Deciding When to Use Partitions](#) in [Chapter 1, Partitions](#).

To create a Pblock for each partition, select the partitions in the Netlist tab one at a time. A Pblock in the PlanAhead tool defines the AREA_GROUP constraints.

To create a Pblock:

1. Right-click a partition instance.
2. Select **Draw Pblock**.
3. In the Device view, draw a rectangular area into which the partition will be placed.

For more information on how to floorplan modules in the PlanAhead tool, see *Design Analysis and Floorplanning (UG676)* cited in [Appendix A, Additional Resources](#).

Synthesizing a Partitioned Design

To synthesize a partition-based design:

1. Create an RTL project.
2. Define partitions using the RTL Design view.
3. Click **Synthesize**.

This procedure runs XST with default options using the incremental technology. XST generates an individual NGC file for each partitioned instance.

To modify the synthesis options before the run:

1. Click **Synthesize**.
2. Select **Synthesis Settings**.
3. Make your changes.

Implementing a Partitioned Design

To implement a partition-based design, follow the steps in the following sections for:

- [Novice Users](#)
- [Advanced Users](#)

Novice Users

This section applies to:

- Novice users
- Users interested in minimal setup requirements

To implement a partition-based design:

1. Click **Implement**.
2. The implementation tools run using the default strategy.

The default strategy is usually the ISE Design Suite default settings for the following tools:

- NGDBuild
- Map
- PAR
- TRACE

To modify the implementation options before the run:

1. Click **Implement**.
2. Select **Implementation Settings**.
3. Make your changes.

Advanced Users

This section applies to advanced users.

To implement a partition-based design:

1. Click **Implement**.
2. Select **Create New Implementation Runs**.

This option:

- Can be used to create multiple implementations with varying implementation options.
- Is similar to running SmartXplorer in the command line.

The results of the implementation can be monitored:

- In the Compilation Log window, or
- From the status bar, or
- By selecting **Window > Design Runs**

Once the implementation has completed:

1. Click **Implemented Design** to load the results.
2. View the implementation report files to verify that the partitions were properly defined and used by the implementation tools.

Promoting Partitions

When a partition has been successfully synthesized or implemented, it must be promoted for future import runs. *Promoting* a partition in the PlanAhead tool is the same as *exporting* a partition in the command line flow.

To promote partitions from the active run, click **Promote Partitions**.

Failing to promote a run loses the current partition results if the run is reset.

Once the results are promoted, you can reset the current run, and rerun it as many times as necessary. The promoted results are imported as long as the partition has not changed. Promoting new results overwrites the current promoted data for a particular run.

For more information on managing multiple runs and promoted data, see *Leveraging Design Preservation for Predictable Results (UG747)* cited in [Appendix A, Additional Resources](#).

Managing Partition Attributes

You can modify the following partition attributes:

- [Action](#)
- [Import From](#)
- [Preservation](#)

Action

The **Action** partition attribute defines the value of the partition state (*implement* or *import*) that tells the tools to either:

- Synthesize or implement the partition, or
- Import it from a previous run.

Import From

The **Import From** partition attribute defines the location of the run to import a partition from. If Action is set to *implement*, this value is set to NA.

Preservation

The **Preservation** partition attribute defines the preservation level to be used by the tools when importing a partition. The values are:

- Routing (default)
- Placement
- Synthesis

Managing the Action and Import From Fields

When a partition is promoted, the PlanAhead tool:

- Sets **Action** to **import**.
- Sets **Import From** to the location selected during the last promote.

Turning Off Automatic Management

To turn off automatic management, deselect **Automatically manage Partition action and import location** in the Promote Partitions dialog box.

Out of Date Runs

The PlanAhead tool does not automatically revert the **Action** field back to **implement** if the promoted run for a partition is out of date.

A promoted run becomes out of date when:

- A source file (HDL or Netlist) is updated, or
- A physical constraint associated with a partition has changed.

This affects promoted *implementation* data only, not promoted *synthesis* data.

When the run is out of date, the source does not match the promoted data, generating an NGDBuild error.

```
ERROR:NgdBuild:1037 - The logic for imported Partition '/top/Express_Car'
using previous implementation
'../../../../project_1.promote/Ximpl_1/top_prev_built.ngd'
has been modified. This situation can occur when the source for the
Partition was modified but the Partition was not re-implemented
and exported.
You must re-implement and export the Partition before it can be imported into this design.
```

Managing the Preservation Attribute

The PlanAhead tool does not manage the Preservation attribute. You must manage the Preservation attribute manually.

1. Select **Implement > Specify Partitions**.
2. Change the **Preservation** attributes in the Specify Partitions dialog box.

Partition attribute values for synthesis and implementation are independent of each other. In some cases, attribute values must be updated in both locations.

Managing Design Runs

The design can be re-implemented when:

- The design changes have been made.
- Partition states have been set correctly.

Recommended Flow

The recommended flow for design preservation is:

1. Maintain a single design run (**impl_1**).
2. Promote and re-implement as necessary.

Re-Implementing the Design

After promoting a successful implementation, click **Implement** to re-implement the design.

Re-implementing the design:

- Resets the run data.
- Launches the implementation tools.
- Imports partitions as defined by the Partition settings.

Promoting the Results

Once the implementation has completed, the results can be promoted. Previously promoted results are overwritten. As a result, only one `promote` directory exists for the design partitions.

It is sometimes advantageous to have multiple `promote` locations, or to import partitions from multiple locations. In these cases, you must manage, promote, and import locations to ensure correct results.

Design Preservation Flows

Design preservation:

- Reduces the number of implementation iterations during timing closure.
Once a portion of the design meets timing, the implementation results (placement and routing) are used in the next iteration.
- Prevents portions of the design that are complete, and that meet timing, from being affected by changes in other parts of the design.
- Uses partitions to preserve the previous implementation results for a module instance.

Using partitions carefully:

- Reduces the number of design iterations.
- Shortens timing closure.
- Eliminates re-verification of unchanged instances.

Implementation Runtime

Preserving portions of the design can affect implementation runtime, depending on:

- Which modules are being implemented, and
- Which modules are being preserved.

Longer Runtime

Runtime can be *longer* if the implemented module has extremely tight timing requirements.

Shorter Runtime

Runtime can be *shorter* if:

- The implemented module easily meets timing, and
- The critical paths are in the preserved modules.

Command Line Design Preservation Flow

This section discusses the command line design preservation flow, and includes:

- [User Management](#)
- [Command Line Design Preservation Flow Steps](#)

User Management

When you run the design preservation flow from the command line, you are responsible for managing:

- Which modules have been updated, and
- Which partitions must be implemented instead of imported.

Follow these guidelines:

- Edit the PXML file in a text or XML editor.
- No special implementation options are necessary to invoke the flow.
- The PXML file must reside in the directory in which the implementation is run.

For more information on creating and managing the PXML file, see [Chapter 4, Command Line Partition Flow](#).

Command Line Design Preservation Flow Steps

The following steps outline the command line design preservation flow.

1. A design architect partitions the design early in the design cycle.
2. The design is initially coded.
3. The design is synthesized using an incremental or bottom-up synthesis flow.
For more information on supported synthesis tools and flows, see [Chapter 3, Synthesis Partition Flow](#).
4. The design is implemented with a PXML file in which all partitions are set to **implement**.
5. Once timing has been met on one or more partitions, the results are exported for future iterations.
6. Modified partitions are re-implemented as the design is modified for bug fixes and feature enhancements.
7. Partitions unchanged at the netlist level can be imported to maintain identical placement and routing information.
8. The NGDBuild tool issues an error if the netlist for a partition being imported does not match the design specified in the import location. You must change the partition state to **implement**.
9. When a partitioned module has been completed with successful timing and verification results, it can continue to be imported as changes to other parts of the design are made.

PlanAhead Tool Design Preservation Flow

This section discusses the PlanAhead™ tool design preservation flow. The design preservation flow is a partition-based flow.

See:

- [Chapter 5, PlanAhead Tool Partition Flow](#)
- *Leveraging Design Preservation for Predictable Results (UG747)* cited in [Appendix A, Additional Resources](#).

PlanAhead Tool Design Preservation Flow Steps

The following steps outline the PlanAhead tool design preservation flow.

1. Create a new Register Transfer Level (RTL) PlanAhead tool project in the RTL flow to add all existing:
 - RTL code
 - User Constraint Files (UCF)
2. Open the RTL Design View to elaborate the RTL design.
3. Define partitions by:
 - Using the PlanAhead tool, or
 - Importing an existing PXML file.
4. Synthesize the design in the PlanAhead tool with all partition states set to **implement**. This increases the incremental capability of Xilinx® Synthesis Technology (XST) to generate individual NGC files for each partition.
5. Create any necessary constraints, such as:
 - Timing constraints, for example:
 - PERIOD
 - OFFSET IN
 - OFFSET OUT
 - Floorplanning constraints, for example:
 - I/O pin LOC
 - AREA_GROUP
6. Implement the design with all partition states set to **implement**.
7. Promote synthesis and implementation results on any successful (correct static and timing results) partitions.
8. Iterate on synthesis and implementation while importing promoted partitions all within the PlanAhead tool.

Netlist Design Preservation Flow

This section discusses the Netlist design preservation flow.

Netlist Design Preservation Flow Steps

The following steps outline the Netlist design preservation flow.

1. Run bottom-up or incremental synthesis on the design outside the PlanAhead tool.
2. Create a new netlist-based PlanAhead tool project that:
 - Uses the synthesis results from the previous step
 - Reads in any existing UCF constraint files
3. Define partitions by:
 - Using the PlanAhead tool, or
 - Importing an existing PXML file
4. Create any necessary constraints, such as:
 - Timing constraints, including:
 - PERIOD
 - OFFSET IN
 - OFFSET OUT
 - Floorplanning constraints, including:
 - I/O pin LOC
 - AREA_GROUP
5. Implement the design with all partition states set to **implement**.
6. Promote implementation results on any successful partitions.
Successful partitions are those with correct static and dynamic timing results.
7. Iterate synthesis outside the PlanAhead tool.
8. Iterate implementation while importing promoted partitions using the PlanAhead tool.

Team Design Flows

The Team Design flow:

- Is a hierarchical design method.
- Uses partitions to allow a large, complex design to be broken up into smaller logical blocks.

These blocks can be implemented independently and simultaneously. This allows each block to be individually designed, implemented, and verified in context with the rest of the design.

When all blocks are complete, the entire design is brought together in an assembly run in which results can be imported and preserved.

Team Design Flow Team

The Team Design flow team consists of:

- One Team Leader (TL)
- One or more Team Members (TM)

Team Leader

Xilinx® recommends that the Team Leader be:

- Experienced with the ISE® Design Suite
- Familiar with the target architecture

The Team Leader is responsible for:

- Design, synthesis, implementation, and verification of the top level logic
- Creation of a top level User Constraint File (UCF) containing timing and floorplanning constraints
- Final assembly of the design

Team Members

There is no required number of Team Members. The number of Team Members typically equals the number of blocks into which the design can logically be broken. The Team Members are responsible for the design, synthesis, implementation, and verification of the partition assigned to them.

Team Design Flow Overview

The Team Design flow:

- Uses partitions to allow independent timing closure and verification of each module by importing each Team Member block into the final assembled design.
- Is an iterative process in which each Team Member periodically publishes the latest version of their block for the Team Leader to assemble.
- Allows for any timing issues on the partition interfaces to be discovered and fixed early in the design cycle.

As the design approaches finality, and the placement of each partition is optimized, the final assembly may simply be a run that imports all partitions in the design.

If timing is not met on the final assembly:

- Some partitions may need to have the partition preservation level relaxed, or
- A partition state may need to be set to *implement*.

Updates to an already assembled design can be made in a similar manner. Only the updated partitions need to be implemented. The other partitions (including the top partition) can be imported.

High Level Team Design Flow Diagram

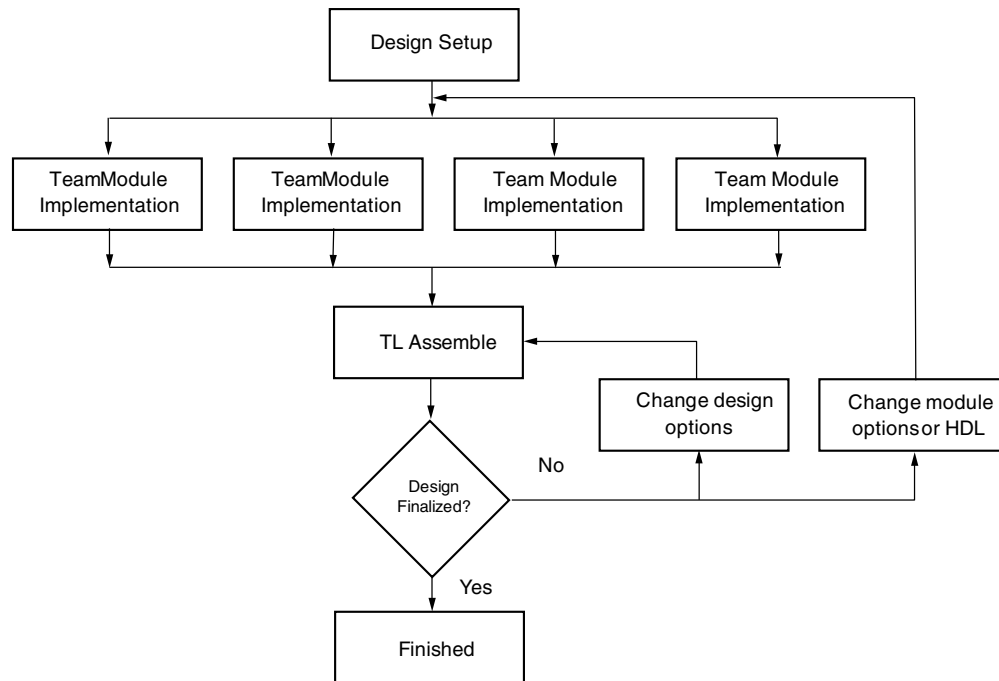

X12122

Figure 7-1: High Level Team Design Flow

Team Design Flow Setup

The Team Leader sets up the Team Design flow.

The steps in the Team Design flow setup are:

- [Define Hierarchy](#)
- [Create RTL](#)
- [Project Setup](#)
- [Initial Synthesis](#)
- [Constraint Definition](#)
- [Initial Implementation](#)
- [Promote or Export](#)
- [Project Delivery](#)

Team Design Flow Setup Diagram

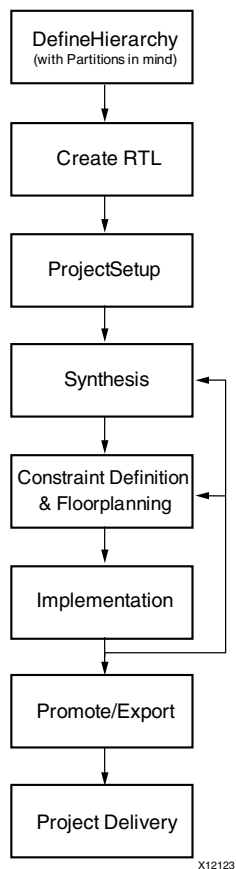

Figure 7-2: Team Design Flow Setup

Define Hierarchy

A correct hierarchy:

- Restricts the effects of optimization and packing limitations.
- Is critical to the success of the design.
- May require adding a level of hierarchy to define a clear boundary at which a Team Member partition is defined.

The Team Leader creates the design plan and identifies the partitions.

Create RTL

The initial setup requires a minimum amount of the design, including:

- The top level module with all I/O ports.
- Correct hierarchy, including instantiations of all Team Member blocks.
- As much global logic (clocking and resets) as possible.
- IP cores in the top partition (optional).

Each Team Member block can range from a black box to full Register Transfer Level (RTL). Module or component declaration is required to define the port directions and port widths.

Project Setup

The ISE® Design Suite and the PlanAhead™ tool both support Team Design flow. Both flows require some initial setup. You must decide on:

- Command line flow or PlanAhead tool flow
- Synthesis tool
- Type of synthesis
- Synthesis and implementation options
- Source control

The Team Design flow allows for considerable flexibility in managing sources. Xilinx recommends that each Team Member have their own copy of the source files. To do so:

- Use a version control system.
- Allow each Team Member to have a local sandbox that can be updated as necessary.

Both the command line flow and the PlanAhead tool flow support this method. PlanAhead tool users can also copy the sources into the project. This allows all Team Members to have a local copy of common sources.

These methods allow one Team Member to update sources without affecting the other Team Members. If all Team Members share the same sources, changes to the source immediately affect all Team Members. This can cause exported implementation data to become stale. This recommendation allows modifications to be tested and verified prior to updating a golden repository.

Initial Synthesis

The initial synthesis should confirm that all modules are correctly defined.

Team Member modules can be:

- Full or partial RTL, or
- A module definition for a black box.

Because of its independent nature, the Team Design flow:

- Does not support a flat top-down synthesis flow.
- Requires either:
 - A bottom-up synthesis flow, or
 - A top-down incremental synthesis flow

For bottom-up synthesis, the Team Member partitions are synthesized out of context with respect to the top partition. For this reason, the Team Members require only the synthesized netlist for the top partition. Implementation is in context.

The Team Design flow is based on the Xilinx Synthesis Technology (XST) incremental flow supported in the ISE Design Suite. In this flow, each Team Member partition is synthesized in context with the top partition. For this reason, each Team Member:

- Requires the top level Hardware Design Language (HDL) code.
- Can import the top partition during synthesis to maintain results across all Team Member partitions.

See [Chapter 3, Synthesis Partition Flow](#).

Constraint Definition

The Team Leader creates a top level User Constraint File (UCF) containing:

- I/O logic constraints and attributes, such as:
 - I/O and LOC placement constraints
 - IOSTANDARD timing constraints
 - OFFSET IN timing constraints
 - OFFSET OUT timing constraints
- Global clock timing and placement constraints, such as:
 - LOC constraints for BUFG, PLL, and MMCM components
 - PERIOD constraints
- The placement of each Team Member partition using the AREA_GROUP constraint.

Because the Team Leader manages the clocking and global resources to ensure that each partition has access to needed resources, the Team Leader must be familiar with the target architecture.

Initial Implementation

All implementations, including Team Member implementation runs, are in context with the top level logic. Because most of the design has not yet been created, the initial implementation may not yet yield meaningful placement or timing results.

Implementation can verify that:

- All modules are properly resolved.
- Partitions are correctly defined.
- All timing and physical constraints have correct syntax.

A partition defined as a black box is supported for synthesis and implementation with no special options or attributes. Even if some or all Team Member partitions are black boxes, it is still possible to implement these blocks because of the partition flow. The NGDBuild tool issues a warning that the partition is being implemented as a black box.

Promote or Export

Synthesis and implementation results can be *promoted* or *exported* at any stage.

During the initial design setup, it is unlikely that there will be any useful implementation data for a top partition or a Team Member module. Nonetheless, it is possible that the top level logic has a completed IP core that was also partitioned.

Because each Team Member implements in context with the top partition, the IP core can be exported for each Team Member to import during their implementation runs.

In the XST incremental flow, the Team Member can import the top level synthesis results to achieve a consistent top level across all Team Member partitions. This is not necessary if the Team Member uses a bottom-up synthesis flow, because each Team Member synthesis is out of context with the top partition.

Project Delivery

The Team Leader provides the project files to each Team Member when:

- Partitions have been defined.
- Constraints have been created.
- The design has been synthesized and implemented.

Command Line Project Delivery

The command line project delivery includes:

- Synthesis projects
- HDL code
- UCF files

PlanAhead Tool Project Delivery

The PlanAhead tool project delivery includes a copy of the Team Leader project for each Team Member.

The Team Leader uses the **File > Save Project As** command to give all Team Members their own copy. This ensures that all Team Members have identical data to start their development phase.

Team Member Responsibilities

Each Team Member is responsible for the development, verification, and timing closure of their module. This process is repeated throughout the design cycle.

The required steps for each Team Member are:

- [Develop and Update Module \(Team Member\)](#)
- [Module Synthesis \(Team Member\)](#)
- [Implementation \(Team Member\)](#)
- [Export or Promote \(Team Member\)](#)
- [Import \(Team Member\)](#)

Team Member Development Flow Diagram

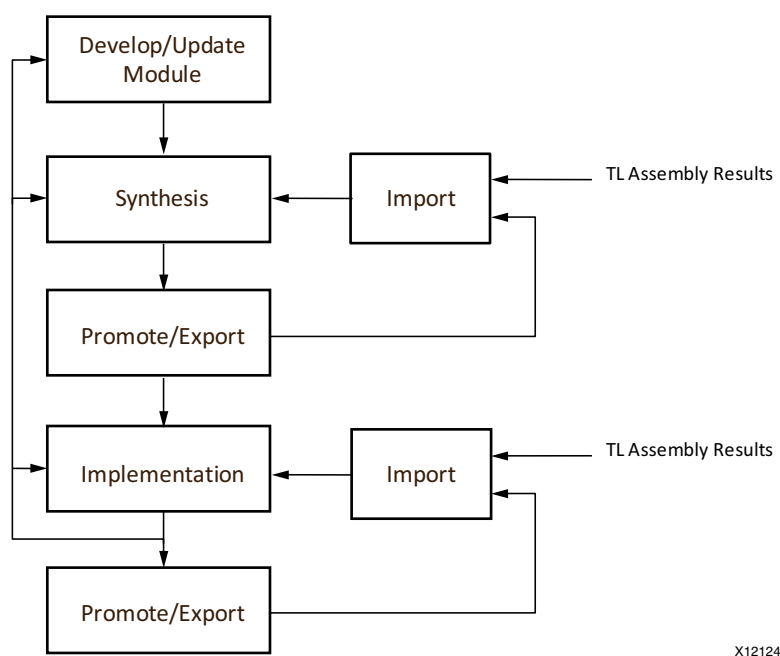

Figure 7-3: Team Member Development Flow

Develop and Update Module (Team Member)

Developing and updating the module involves creating or modifying HDL code.

The Team Member:

- Creates or modifies their HDL code.
- Delivers any changes to the Team Leader if:
 - The partition interface changes, or
 - A new feature is implemented, or
 - There is any change to the Team Member partition.

The Team Leader:

- Updates the top level.
- Delivers the top level to the other Team Members.

Module Synthesis (Team Member)

Each Team Member module can be synthesized:

- Independently from the top partition using a bottom-up flow.
The Team Leader provides the top level netlist to each Team Member for implementation.
- In context with the top partition using an incremental flow.
 - Each Team Member requires the top level HDL code to synthesize their module in context with the top partition.
 - The results from the latest Team Leader run can be imported to prevent the top level logic from varying among Team Members.

Implementation (Team Member)

The Team Member implements the block in context with the top partition.

Xilinx recommends that you:

- Set the top partition to *implement* in most cases.
- Always set the other Team Member blocks to *import*, or *implement* them as a black box.
- Import other Team Member partitions from a Team Leader assembly run that met all partition interface timing.

For information on closing timing when other Team Member partitions are implemented as black boxes, see [Black Box Usage](#) in [Chapter 1, Partitions](#).

Methods for Closing Timing

The Team Member uses all available methods to close timing, including:

- Creating physical constraints such as:
 - AREA_GROUP
 - LOC
- Creating special timing constraints, such as
 - Multi-cycle paths
 - False paths
- Using tool options
- Using tools such SmartXplorer

Delivering Constraints

It may not be necessary to deliver all constraints to the Team Leader if the Team Member partition is being *imported*. However, the constraints should be readily available in case the Team Leader needs to *implement* the Team Member partition.

Team Leader Actions

As the Team Member delivers a new version of their block to the Team Leader, the Team Leader:

- Validates the timing with the latest version of the design.
- Exports new results for all Team Members.

Implement or Import

Xilinx recommends that each Team Member *implement* (instead of *import*) the top level for implementation until the design begins to converge. The Team Member can then decide whether to *import* or *implement* the top partition.

Export or Promote (Team Member)

To prevent unexpected results in the final assembly, Xilinx recommends that each Team Member *export* (command line) or *promote* (PlanAhead tool) their results to the Team Leader frequently throughout the design process. This process allows potential issues to be identified and fixed when during development.

Import (Team Member)

Each Team Member can *import* or *implement* other partitions for synthesis and implementation. While there is considerable flexibility in this task, Xilinx recommends that each Team Member:

- *Import* the top partition during synthesis, if using incremental synthesis.
- *Implement* the top partition during implementation, at least until the design is complete enough that the exported results from an assembly run accurately represent the placement and routing required by the final design.
- *Import* (or black box) other Team Member blocks during synthesis, if using incremental synthesis.
- *Import* (or black box) other Team Member blocks during implementation.

Note: Xilinx recommends that each Team Member import a Team Member block from the promoted Team Leader data, not directly from other Team Members. This ensures that all Team Members are working on the same version of the design.

Team Leader Responsibilities

The Team Leader manages the assembly flow. The goal of the assembly flow is to achieve a completely assembled design that:

- Is fully placed and routed.
- Meets timing.

Assembly may be easy or difficult depending on:

- How full and how fast the design is, and
- How closely the Team Members work together throughout the design flow.

Assembly is an iterative process. As each Team Member obtains new results to share with the Team Leader and the other Team Members, they export this data to the Team Leader for an assembly run.

Based on the results of the assembly run, the Team Leader either:

- Works with individual Team Members to resolve issues, or
- Exports the successful results to all Team Members.

Assembly Flow Diagram

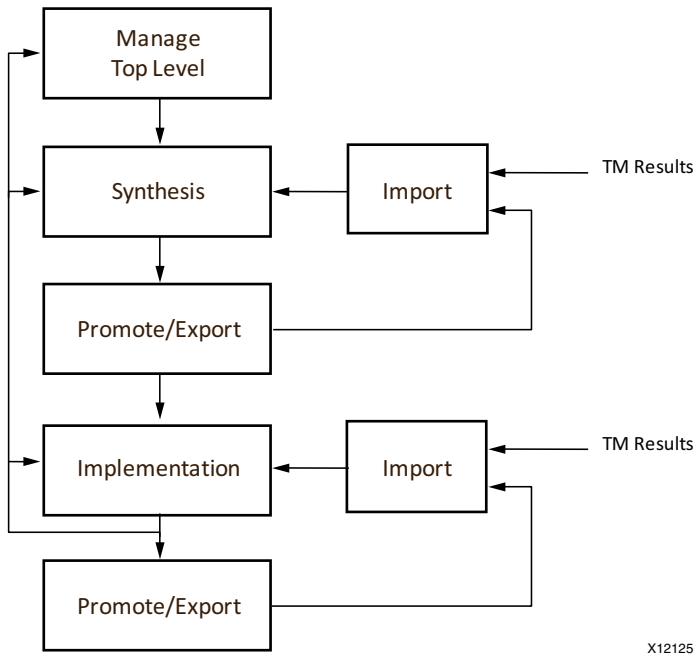

Figure 7-4: **Assembly Flow**

Manage Top Level (Team Leader)

The Team Leader develops and maintains the top level.

Depending on how much logic is in the top partition, the Team Leader may continue to develop the top partition throughout the whole design process as the Team Members continue to develop their blocks.

If the top partition is mainly I/O and clocks, little additional development work may be required after the initial design setup.

Synthesis (Team Leader)

When using the incremental XST flow, the Team Leader can:

- Obtain the latest RTL code from each Team Member and synthesize the design as a whole, or
- Import the latest results from the exported synthesis results of each Team Member.

Unless there is a need to re-synthesize the entire design, importing the latest NGC files is sufficient. This helps ensure consistency among the Team Leader and Team Members.

Implementation (Team Leader)

Implementation in the assembly phase uses the latest results from each Team Member. The Team Leader:

- Addresses any timing issues within the top partition.
- Identifies timing issues between Team Member partitions.
- Manages the constraint files.

Team Member User Constraint File (UCF)

Each Team Member can have a User Constraint File (UCF) in addition to the top level UCF. The Team Member UCF contains timing or placement constraints specific to the Team Member block.

To incorporate these constraints into the Team Leader implementation, the Team Leader:

- Manually concatenates the files, or
- Adds multiple UCF files to the PlanAhead tool project, or
- Specifies multiple UCF files at the command line (NGDBuild tool)

If there are multiple UCF files, there must be no overlapping constraints. If two constraints constrain the same logic with different values, the last constraint read in by the implementation tools prevails. This conflict can lead to unpredictable results.

Import or Implement Team Member Blocks

During implementation, the Team Leader must *implement* or *import* each Team Member block.

- *Implementing* each Team Member block:
 - Allows for greater flexibility in the placement of the top partition.
 - May be necessary early in the design cycle to identify timing issues.
- *Importing* each Team Member block can take place as:
 - The block becomes more complete, and
 - Partition interface timing is met.

Final Assembly

Final assembly occurs when every Team Member block is final. At this stage:

- Each Team Member block is imported.
- The top partition can be *implemented* or *imported* depending on the timing results.
- The preservation level on a Team Member block can be relaxed.

Relaxing the preservation level allows minor placement and routing adjustments to a Team Member block that is being imported.

- Individual partitions can be set to *implement* if:
 - Small changes are made to one Team Member block, or
 - Timing does not converge on the assembly run.

Promote or Export (Team Leader)

As each Team Member provides the Team Leader with more complete versions of their blocks, the implementation results begin to converge. The Team Leader exports (or promotes) the latest synthesis and implementation results to each Team Member.

Note: Xilinx recommends that each Team Member import a Team Member block from the promoted Team Leader data, not directly from other Team Members. This ensures that all Team Members are working on the same version of the design.

In most cases, the Team Leader exports the implementation data only. However, the Team Leader can also:

- Promote the synthesis results so that all Team Members have the latest netlist for every other Team Member block.
- Iterate on synthesis of the top level while importing each Team Member block.

Import or Implement (Team Leader)

The Team Leader decides whether to *import* or *implement* each Team Member block for:

- Synthesis
- Implementation

Import or Implement Team Member Blocks for Synthesis

The Team Leader decides whether to *import* or *implement* each Team Member block for synthesis (when incremental synthesis is used). Xilinx recommends that the Team Leader:

- Import the Team Member results, or
- Use the XST **read_cores** option to read in the latest NGC file for each block.

Import or Implement Team Member Blocks for Implementation

The Team Leader decides whether to *import* or *implement* each Team Member block for implementation. Xilinx recommends that the Team Leader *import* the Team Member block whenever possible.

If interface timing to the top level or other Team Member blocks is not met, it may be necessary to *implement* some or all Team Member blocks until interface timing is stable.

Change the Preservation Level (Team Leader)

The Team Leader can change the preservation level of imported partitions to:

- Placement, or
- Synthesis

Change the Preservation Level to Placement

The Team Leader can change the preservation level of imported partitions to *placement* if routing conflicts occur. Changing the preservation level to *placement* allows the router to change the routing.

Change the Preservation Level to Synthesis

The Team Leader can change the preservation level of imported partitions to *synthesis* if:

- Timing is not met, or
- Placement conflicts occur.

Changing the preservation level to *synthesis* allows the implementation tools to make minor changes to placement and routing. If the Area Group constraint requirements for the Team Design flow are followed, no placement conflicts should occur.

Change the Partition State

The Team Leader can change the partition state from *import* to *implement* when:

- Adjusting the preservation level does not allow the design to converge, or
- Small changes are made to an already assembled design.

Design Recommendations for All Partition-Based Designs

The following design recommendations apply to *all* partition-based designs, including the Team Design flow.

- Register signals on both sides of the partition boundary.
- Partition logic into groups that are functionally independent from the rest of the design.
- Keep logic that must be packed together inside the same partition.

Design Recommendations for Team Design Flow Only

The following design recommendations apply specifically to the Team Design flow:

- [Floorplan Team Member Blocks to a Specific Region](#)
- [Provide a Stage of Pipeline Registers](#)
- [Black Box Modules](#)
- [Top Level Design](#)

Floorplan Team Member Blocks to a Specific Region

Each Team Member block (excluding the top level team leader logic) must be floorplanned to a region of the device using AREA_GROUP constraints. These constraints:

- Control the placement of the logic.
- Prevent placement conflicts during assembly.

Overlapping AREA_GROUP Constraints

Overlapping AREA_GROUP constraints between team members are not supported.

Controlling the Routing of the Block

Use AREA_GROUP constraints to control the routing of the block. Routing conflicts can occur during assembly:

- In designs that are heavily congested with routing.
- In team member blocks that are next to or near another team member block.

Controlling the routing of each team member block can:

- Remove or reduce routing conflicts.
- Make assembly more robust.

Since the routes must be controlled in the individual team member runs, make the decision to control routing early in the design cycle.

Additional Required Constraints

Two additional constraints are required to control routing on an AREA_GROUP.

- CONTAINED=ROUTE
Directs the router to use only those routing resources owned by the AREA_GROUP.
- PRIVATE=NONE
Allows logic from the top level to be placed inside a team member AREA_GROUP.

Note: While this is the normal behavior of an AREA_GROUP, this constraint must currently be explicitly set when using CONTAINED=ROUTE.

These constraints are applied to the team member block whose routing it controls.

Constraint Syntax Example

The following syntax example for these constraints uses an instance called **cpuEngine**.

```
INST "cpuEngine" AREA_GROUP = "pblock_cpuEngine";  
AREA_GROUP "pblock_cpuEngine" RANGE=SLICE_X64Y60:SLICE_X105Y119;  
AREA_GROUP "pblock_cpuEngine" CONTAINED=ROUTE;  
AREA_GROUP "pblock_cpuEngine" PRIVATE=NONE;
```

Behavior of CONTAINED=ROUTE

The following important information describes the behavior of CONTAINED=ROUTE.

Components Owned by the Partitioned Instance

The partitioned instance owns only those components with explicit RANGE constraints.

Paths That Contain Routing

Routing is contained only in paths in which both drivers and loads are owned by the team member partition.

A path can logically belong to the team member block, but either a driver or a load is not physically owned by the partition. Examples include global logic residing in the middle of the device, such as:

- BUFG
- MMCM

- SYSMON
- ICAP

Paths Not Physically Owned by Team Member Partition

Paths not physically owned by the team member partition may use routing resources outside the team member area.

- These paths are not contained, and are potential routing conflicts during assembly.
- To avoid or minimize these paths, keep clocking logic and special components in the top level partition.

Paths Physically Owned by Team Member Partition

Routing is contained in paths that are physically owned by the team member partition. These paths can use only those routing resources owned by the team member partition.

If routing with the partition's AREA_GROUP is over-utilized, it may be necessary to add RANGE constraints for components not used by the partition. Adding these additional range constraints may help if:

- A team member partition does not use some components (for example, block RAM or DSP components), and
- The slice RANGE spans these unused components.

Adding RANGE constraints for these unused components:

- Allows the team member block to own the associated routing resources.
- Increases the routing available to the partition.
- Potentially improves routing, timing, or both.

Provide a Stage of Pipeline Registers

If possible, provide a stage of pipeline registers for timing critical paths going from one partition to another in the top partition. These timing critical paths include:

- Team Leader to Team Member
- Team Member to Team Member

Because of the Area Group requirement of Team Design flow, this allows greater flexibility to meet timing to logic that is placement-restricted (for example, Team Member blocks).

Black Box Modules

Black box modules are supported. If a Team Member module does not yet exist, or if a black box is desired for timing or run time benefits, it can be left as a black box for both synthesis and implementation. See [Black Box Usage](#) in [Chapter 1, Partitions](#).

Top Level Design

The top level design:

- Contains all I/O buffers.
- Is limited to a small amount of logic.

What constitutes a small amount of logic is open to interpretation, and is often design dependent. In general, the more logic in the top partition, the more complicated the final

assembly. Child partitions inside the top partition that belong to the Team Leader help keep the amount of logic implemented during assembly to a minimum.

Command Line Flow

The ISE Design Suite command line flow requires no special switches or tools. All partition information is stored in the PXML file.

SmartXplorer

The Team Leader and the Team Members can use SmartXplorer to identify the implementation options that work well for the particular design. See [Using SmartXplorer in Partitioned Designs](#) in [Chapter 5, PlanAhead Tool Partition Flow](#).

PXML Files

When running the Team Design flow from the command line, each Team Member (including the Team Leader) manages their own PXML file. The PXML file must be named `xpartition.pxml`.

For sample PXML files, see:

- [Sample PXML File \(Team Leader\)](#)
- [Sample PXML File \(Team Member\)](#)

Command Line Flow Directory Structure

There is no required directory structure for a TD project. Source files are commonly controlled with a version control system such as Perforce or CVS. Each Team Member checks out a local sandbox from the repository.

The following sample directory structures can be used to begin the project.

Team Leader Command Line Flow Directory Structure

- TL
 - Synth
Synthesis Results of the top partition and Team Member partitions
Note: For bottom-up or incremental synthesis projects
 - HDL
 - VHDL or Verilog source files for the Team Member block
 - Black box module definitions for Team Member partitions that do not yet exist
 - UCF
 - Top level UCF files
 - TM-specific UCF files
 - Impl
 - Top level implementation results
 - Latest version of each Team Member design
 - `xpartition.pxml`

- XImpl
 - Exported or Promoted results of the latest implementation
Team Members can import the top partition and other Team Member blocks from this directory. If some Team Members lack easy access to this location, choose a more suitable *export* location.
- Assemble
 - Final implementation of design in which each Team Member block is imported.
 - The top partition can be implemented or imported depending on timing results.

Team Member Command Line Flow Directory Structure

- TM
 - Synth
 - Synthesis results of the Team Member block for a bottom up synthesis project, or
 - Results of the top partition plus the Team Member block (incremental synthesis in context with the top partition)
If little HDL exists for the Team Member block, this should be the synthesis results of a proxy HDL file in which all inputs and outputs are registered for interface timing purposes to other partitions.
 - HDL
 - VHDL or Verilog source files for the entire design
 - VHDL or Verilog source files for the top partition (if using in context incremental synthesis flow)
 - Black box module definitions for Team Member partitions that do not yet exist
 - UCF
 - Top level UCF files
 - TM-specific UCF files with specific physical constraints to the Team Member partition, such as LOC and AREA_GROUP
 - Impl
 - Implementation results of the Team Member block that imports other Team Member blocks and implements or imports the top partition.
 - `xpartition.pxml`
 - XImpl
 - Exported results of the latest Team Member implementation
Can be used by the Team Leader to import the Team Member block for assembly runs.

If the Team Leader lacks easy access to this location, choose a more suitable *export* location.

Team Leader Command Line Flow Responsibilities

The Team Leader implements the entire design with the latest version of the top partition and each Team Member block. As with all implementations in this flow, a partition is placed on each Team Member block and on the top partition. When a lower level partition is added to the design, Top must be a partition.

Sample PXML File (Team Leader)

```
<?xml version="1.0"?>
<Project Name="impl_1" FileVersion="1.2" ProjectVersion="2.0">
  <Partition Name="/top" State="implement" ImportLocation="NONE">
    <Partition Name="/top/U0" State="implement" ImportLocation="NONE" Preserve="routing">
    </Partition>
    <Partition Name="/top/U1" State="implement" ImportLocation="NONE" Preserve="routing">
    </Partition>
    <Partition Name="/top/U2" State="import" ImportLocation="../../TM3/Ximpl"
Preserve="routing">
    </Partition>
  </Partition>
</Partition>
```

As Team Member blocks become final, and for the final assembly, the state of each Team Member partition can be set to *import*. The **ImportLocation** now points to the directory to which the Team Member partition was exported. After a successful implementation, the Team Leader exports the results to the Team Members.

Team Members can *import* or *implement* the top partition, but should always import other Team Member blocks from this exported Team Leader run.

Team Member Command Line Flow Responsibilities

Each Team Member implements their design in context with the top partition while importing other Team Member partitions. Each Team Member will likely implement the top partition, providing greater flexibility for the individual Team Member block.

As the design converges, and the Team Member tweaks a Team Member block, the top partition can be imported to help preserve interface timing.

After successfully implementing the design, the Team Member:

- Exports the implementation results for the Team Leader.
- Provides the Team Leader with the latest version of the source (netlist and possibly HDL) for their block.

This ensures synchronization of the source and exported partition data, and prevents any false logic change detection errors in the NGDBuild tool.

After running implementation with the latest version of the design, the Team Leader exports the results to all Team Members.

Note: Xilinx recommends that each Team Member import a Team Member block from the promoted Team Leader data, not directly from other Team Members. This ensures that all Team Members are working on the same version of the design.

Sample PXML File (Team Member)

```
<?xml version="1.0"?>
<Project Name="impl_1" FileVersion="1.2" ProjectVersion="2.0">
  <Partition Name="/top" State="import" ImportLocation="../../TL/Ximpl ">
    <Partition Name="/top/U0" State="implement" ImportLocation="NONE" Preserve="routing">
      </Partition>
    <Partition Name="/top/U1" State="import" ImportLocation="../../TM2/Ximpl "
Preserve="routing">
      </Partition>
    <Partition Name="/top/U2" State="import" ImportLocation="../../TM3/Ximpl "
Preserve="routing">
      </Partition>
    </Partition>
  </Partition>
</Project>
```

PlanAhead Tool Flow

While it is possible to perform synthesis outside the PlanAhead tool, and use netlist-based PlanAhead tool projects to implement a Team Design flow, this section assumes the use of RTL PlanAhead tool projects with the XST incremental flow. No special PlanAhead tool settings or licenses are required. See [Chapter 5, PlanAhead Tool Partition Flow](#).

Team Leader Responsibilities (PlanAhead Tool Flow)

The Team Leader follows these steps in the PlanAhead tool flow:

1. Creates an initial RTL PlanAhead tool project.
 - The project *might* contain all source files that exist at this stage of the design.
 - The project *must* contain a top level HDL file which instantiates a black box for the various Team Member modules.
 - The project *should* follow the source management recommendations described in the previous section of this chapter.
2. Defines partitions on the Team Member blocks using the RTL Design view.
 - Defining partitions requires elaboration of the HDL.
 - If the HDL has errors and will not elaborate, partitions cannot be defined.
3. Runs synthesis.
4. Promotes successful results.
5. Adds or creates any necessary global constraints, including:
 - Timing constraints, such as:
 - PERIOD
 - OFFSET
 - FROM:TO
 - Physical constraints, such as:
 - AREA_GROUP constraints for Team Member blocks
 - LOC constraints for clocking logic and I/O

This is referred to as floorplanning.

6. Validates the current design by:
 - Running the PlanAhead tool Design Rules Check (DRC).
 - Running the current design through implementation.

While there may not be useful implementation results at this stage, validating the design provides a check of the design and constraints through the implementation tool's logical and physical DRC checks.

7. Creates one project per Team Member with **Project Save As**.

As each Team Member develops, implements, and promotes their block, this step can be repeated to keep all Team Member projects in sync with the Team Leader project. See the following figure.

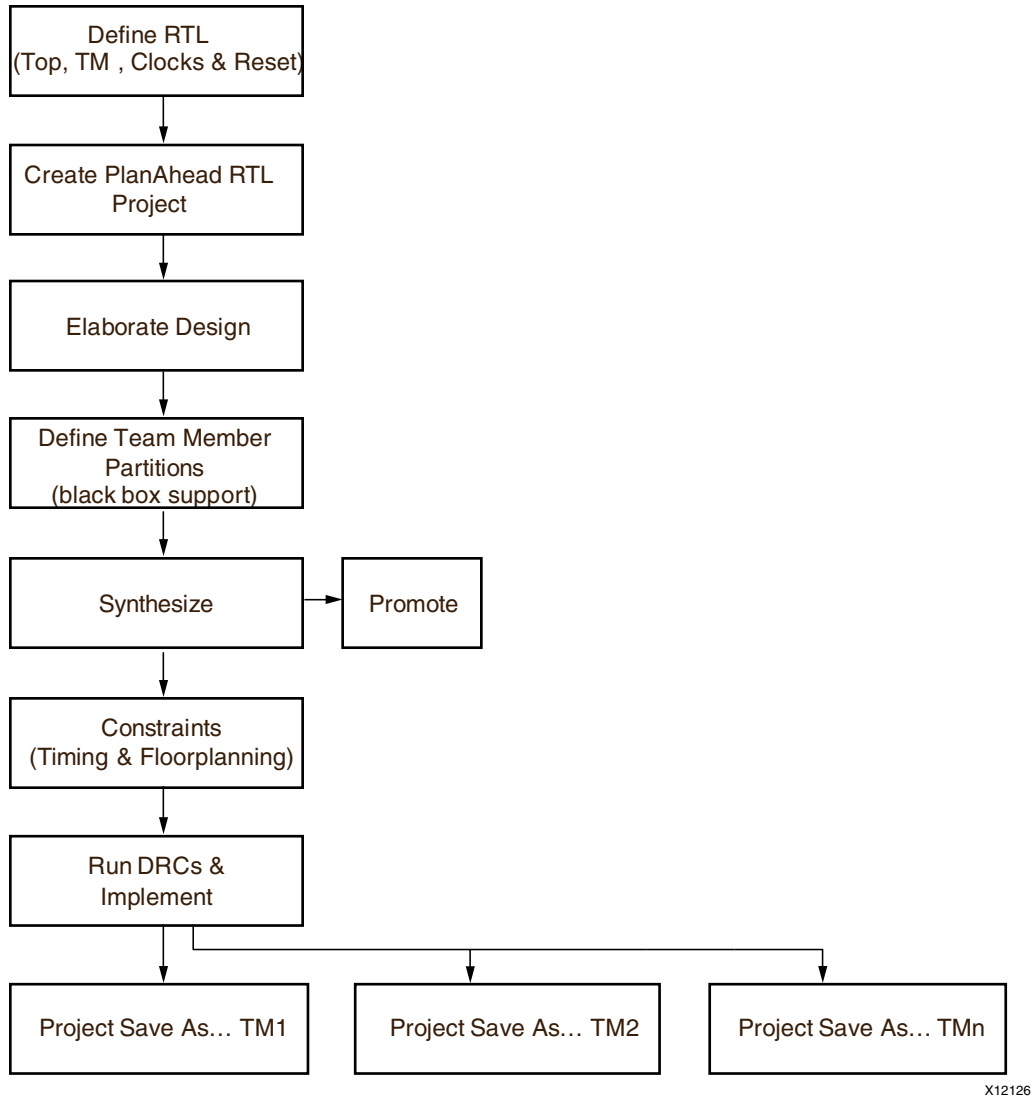

X12126

Figure 7-5: Initial Team Leader PlanAhead Tool Flow

Interface Timing

Specifying the interface timing between partitions in order to meet and maintain timing can be difficult. One partition is often being implemented as another partition is being imported. The tools are unable to place the logic in the ideal locations.

There are two ways to resolve this dilemma, depending on the flow being used.

- [Team Member Partitions as Black Boxes](#)

Constrain the interface logic of one Team Member partition when the other Team Member partitions are defined as black boxes.

- [Team Member Partitions as Interface Logic](#)

Constrain, meet, and maintain interface timing between Team Member partitions when all interface logic is present (no black boxes).

Team Member Partitions as Black Boxes

Interface timing can be budgeted with constraints to the partition pins when:

- The current Team Member is implementing only their logic along with the top partition, and
- Other Team Member partitions are black boxes.

Partition Pin Timing Constraints

The Team Leader initially creates partition pin timing constraints. For an example of constraining proxy logic on a black box module, see [Black Box Usage](#) in [Chapter 1, Partitions](#). The Team Leader then takes the following actions.

Event	Action
<ul style="list-style-type: none"> • Partition pin timing constraints defined 	<ol style="list-style-type: none"> 1. Team Member partitions defined as black boxes 2. Team Leader implements design
<ul style="list-style-type: none"> • Implementation complete, and • Interface timing met 	<ol style="list-style-type: none"> 1. Black box partitions promoted 2. Partition pin locations exported

The Team Members can use this promoted data, along with the appropriate timing constraints, when implementing their block in order to:

- Place the interface logic near the appropriate edge of the partition AG range.
- Meet timing in assembly.

If the locations of the PROXY pins need to be adjusted from the initial Team Leader implementation, use **pr2ucf** to extract the constraints.

```
pr2ucf top_routed.ncd -o partition_pins.ucf
```

These constraints:

- Can be modified manually.
- Cannot be modified using the PlanAhead tool.

The modified locations are passed to each Team Member by:

- Adding the additional UCF to the design flow, or
- Merging the constraints with the top level UCF.

Because the partition pin locations are fixed by means of UCF constraints, the black box modules should be *implemented* (as opposed to *imported*) by each Team Member.

The Team Leader can now:

- Re-implement the black boxes with the modified partition pin locations.
- Re-export (or promote) the results for each Team Member.

Implementing one module with black boxes for the other Team Member partitions can lower memory and runtime. However, this flow runs the risk that the interface timing might not be fully accurate, because:

- No clock skew, fanout, or realistic levels of logic are considered.
- Interface timing issues can arise during assembly.

For more information on using this flow to reduce memory, see [Managing Memory Usage on Large Designs](#) in [Chapter 1, Partitions](#).

Team Member Partitions as Interface Logic

Interface timing can often be ignored early in the design cycle. Each Team Member implements their block while either importing other Team Member blocks, or leaving them as black boxes. Once the interface logic has been defined for a Team Member block, the code is delivered to the Team Leader.

Team Leader Actions

The Team Leader:

- Implements all partitions.
- Identifies and resolves interface timing issues.
- Promotes the results for all Team Members to use.

Team Member Actions

Team Member **A** can continue developing and implementing their block while importing the Team Member **B** block from the promoted Team Leader results.

Team Member **B** does the same for Team Member **A**. The partition interface timing should remain intact.

Flow Advantages

The advantages to this flow are:

- The interface timing is 100% accurate.
- Interface timing issues can be identified earlier in the flow when changes are still being made.
- No special timing or placement constraints have to be created. There is a normal PERIOD in most cases.

Team Member Responsibilities (PlanAhead Tool Flow)

Each Team Member now has a PlanAhead tool project identical to the Team Leader project.

Each Team Member:

1. Develops and adds their sources to the project.
2. Synthesizes, constrains, implements, and promotes their results.

The projects now begin to diverge. Xilinx recommends that Team Members periodically synchronize their projects with the Team Leader project.

Once a Team Member has results that can be used by other Team Members and the Team Leader, the Team Member promotes the synthesis and implementation results to a location that the Team Leader can access.

The Team Leader:

1. Runs synthesis, implementation, or both, using the latest version of the design.
2. Promotes those results for the Team Members to use.

Note: Xilinx recommends that each Team Member import a Team Member block from the promoted Team Leader data, not directly from other Team Members. This ensures that all Team Members are working on the same version of the design.

Debugging Partitions

This chapter discusses debugging partitions, and includes:

- [Implementation Errors](#)
- [Updated Attributed Value Not Used on Imported Partition](#)
- [BitGen DRC Errors](#)
- [ChipScope Support](#)

Implementation Errors

Implementation errors include:

- [A Partition Fails to Import](#)
- [A Design Does Not Meet Timing](#)
- [A Design Does Not Place](#)
- [A Design Does Not Route](#)
- [Slice Utilization Goes Up With Partitions](#)

A Partition Fails to Import

A partition may fail to import for many reasons, including:

- [Changes to the Source Netlist](#)
- [Changes in the Design Analysis Tool](#)
- [PXML File Not Copied to Import Directory](#)

Changes to the Source Netlist

A partition may fail to import if the *source netlist* has changed between:

1. The time when the partition was *exported*, and
2. The time when the partition is *imported*.

This is the most common reason for a failure to import.

Changes in the Design Analysis Tool

A partition may fail to import if the *tool* has changed between:

1. The time when the partition was *exported*, and
2. The time when the partition is *imported*.

There is no guarantee that importing partitions from previous versions will be successful. Attribute values and DRC rules can change from release to release. Imported partitions may need to be modified and reimplemented to accommodate these new requirements. This is especially true for newer architectures that are still being tested.

For example, a design that worked in a previous version may now generate DRC errors on the MMCM such as:

```
ERROR:PhysDesignRules - The calculated CLKIN1_PERIOD frequency/DIVCLK_DIVIDE value of 100.000000 for MMCM_ADV instance clocks/dcm200/DCM_ADV is less than the allowed lower limit of 135.0 MHz, when BANDWIDTH is HIGH or OPTIMIZED. Change BANDWIDTH to LOW to correct this problem.
```

PXML File Not Copied to Import Directory

A partition may fail to import if the PXML file was not copied to the import directory.

The following error message usually indicates that the PXML file was not properly copied.

```
ERROR:HierarchicalDesignC:154 - Import project "./import" is not an XPartition project.
ERROR:HierarchicalDesignC:143 - Error importing Partition "/top/module".
ERROR:HierarchicalDesignC:142 - Error found in XPartition file data.
```

A Design Does Not Meet Timing

If a partitioned portion of a design does not meet timing, relax the preservation level of the imported partitions to *synthesis*. This allows small changes in placement and routing to the imported partitions. Because this gives the tools greater flexibility, timing might be met.

Once timing is met:

- Export the partition.
- Move the preservation level to *placement* or *routing* (optional).

If the design still does not meet timing, it may be necessary to:

- Change the state from *import* to *implement* on one or more partitions, or
- Remove one or more partitions that span critical paths.

Standard flat flow timing closure techniques apply.

A Design Does Not Place

The more partitions there are in a design, and the higher percentage of logic that is imported, the fewer resources are available for the logic being implemented. This may lead to a design that cannot be placed.

The following message during placement may indicate this problem.

```
WARNING: Place:1178 - 4 sites were unavailable during the placement phase because they were already used by routing within preserved Partitions. If the Placer is not able to find a successful solution, the following suggestions might help the Placer find a solution.
1) To allow the Placer to use these sites, back off the preservation level on one or more of the following Partitions. The following Partitions contain unavailable sites:
    Partition /top/Control_Module: 3 (preserve=routing)
    Partition /top/Express_Car: 1 (preserve=routing)
If the problem persists, then careful floorplanning can minimize the number of sites occupied by routing.
```

These sites are not usable because the imported routing makes one or more pins on an otherwise empty component unusable. Logic can be placed in these components if the router has the ability to move imported routing. To do so, change the preservation level to *placement* or *synthesis* on partitions with a high number of unavailable sites. If this is insufficient, you may need to re-implement a partition.

Change Partitions to Implement

Setting the top partition state to *implement* may free up enough resources to allow the placer to find a valid placement. If this is insufficient, you may need to change the other partitions to *implement* as well.

Use the PlanAhead™ tool to analyze which partitions to change to *implement*.

1. Load the placement and routing information in the Results Viewer.
2. Highlight each partition to see where its logic is located in the FPGA device.

Reduce Number of Partitions

Having too many partitions can negatively impact device utilization. Remove partitions on modules that are not on critical portions of the design to free up resources for other logic. This gives the tools greater flexibility to find a solution that meets timing.

Floorplanning

Careful floorplanning can help designs find a permanent placement solution. If all the logic is allowed to spread out throughout the entire chip, the placer may be unable to find resources for the new logic being implemented.

Floorplanning restricts each partition to its own section. If an AREA_GROUP range is added or modified, the exported data of the partition is now out of date. The partition state must be set to *implement* for the next run.

A Design Does Not Route

If a design with imported partitions does not route:

1. Change the preservation level to *placement*.
2. Re-run the PAR tool.

You do not need to re-run the Map tool.

Floorplanning

Just as floorplanning can help solve placement issues, it can also help solve routing issues.

Change Partition Levels to Placement

If changing the preservation level does not yield the desired results, and if floorplanning has not helped, analyze the placed design to determine which partitions need to have the state changed.

Use the PlanAhead tool to analyze which partitions to change to *placement*.

1. Load the placement and routing information in the Results Viewer.
2. Highlight each partition to see where its logic is located in the FPGA device.

Slice Utilization Goes Up With Partitions

Some increased utilization is expected due to the optimization and packing restrictions imposed by partitions. The increased utilization is usually only a few percentage points, and is ideally negligible.

Significantly Increased Utilization

Utilization can increase significantly if the ratio of LUTs to FFs highly favors one over the other.

- In a *non-partitioned* design, the packer can combine some components from **moduleA** with components in **moduleB**.
- In a *partitioned* design, due to packing restrictions, components from **partitionA** cannot be packed with components from **partitionB**. Empty slices must be used for this out-of-balance logic, causing slice utilization to increase.

Area Group and Partition Summary

To check whether a design is affected, review the Area Group and Partition Resource Summary section of the Map Report (.mrp).

Sample Map Report - Partition Resource Summary

```
Partition "/top/moduleA":
State=implement
Slice Logic Utilization:
  Number of Slice Registers:          4,318 (4,318)
  Number of Slice LUTs:              4,337 (4,337)
    Number used as logic:            3,717 (3,717)
    Number used as Memory:           620 (620)
Slice Logic Distribution:
  Number of occupied Slices:          1,750 (1,750)
  Number of LUT Flip Flop pairs used: 5,249 (5,249)
    Number with an unused Flip Flop: 931 out of 5,249 17%
    Number with an unused LUT:       1,508 out of 5,249 28%
    Number of fully used LUT-FF pairs: 2,810 out of 5,249 53%
Number of Block RAM/FIFOs:           3 (3)
Number of BUFDS:                     1 (1)
Number of BUFR:                      1 (1)
Number of GTX_DUAL:                  2 (2)
Number of PLL_ADV:                   1 (1)
```

Utilization Numbers

The Map Report lists two numbers for the utilization:

- The first number shows the resources for the individual partition.
- The second number (in parentheses) shows the resources for the partition and all its child partitions.

This information appears at the top of the Partition Resource Summary section of the Map Report, and can easily be overlooked. Following is an example:

```
Partition Resource Summary:
-----
Resources are reported for each Partition followed in parenthesis by resources for the
Partition plus all of its descendents.
```

Updated Attributed Value Not Used on Imported Partition

Caution! If you update an attribute on an imported MMCM, the tool does not error, but uses the old value. Your changes are lost.

If an attribute for an MMCM (or similar) is modified, but the instance is being imported:

- The old attribute value is imported, overwriting the new value.
- No error or warning message is issued.

When an attribute of an imported partition is modified through Hardware Design Language (HDL) or User Constraint File (UCF) constraints, you must make sure that the partition is implemented. If you do not do so, the new value will not be used.

BitGen DRC Errors

A design may complete the PAR tool, then fail in during the BitGen process. The tool may display Design Rules Check (DRC) errors such as:

```
ERROR:PhysDesignRules:10 - The network <signal_OBUF> is completely unrouted
```

This error is caused by an un-driven output of a partition connected to logic in the parent partition. The Map tool cannot optimize the logic in the parent partition as it can in a flat flow. This results in partially routed signals in the final design, which causes BitGen DRC errors.

This problem can sometimes be corrected by using the **BoundaryOpt** attribute on the partition. This allows the Map tool to trim the unconnected ports.

Because **BoundaryOpt** has limitations, you may need to correct this problem at the Hardware Design Language (HDL) level. In either case, modified partitions must be re-implemented.

ChipScope Support

The ChipScope™ tool supports partitions.

Change the partition state to *implement* on any partition affected by a ChipScope core change.

Additional Resources

Xilinx Resources

- *ISE® Design Suite: Installation and Licensing Guide (UG798):*
http://www.xilinx.com/support/documentation/sw_manuals/xilinx13_4/iil.pdf
- *ISE Design Suite 13: Release Notes Guide (UG631):*
http://www.xilinx.com/support/documentation/sw_manuals/xilinx13_4/irn.pdf
- **Xilinx® Glossary:** <http://www.xilinx.com/company/terms.htm>
- **Xilinx Support:** <http://www.xilinx.com/support/documentation/index.htm>
- **Xilinx Device User Guides:** http://www.xilinx.com/support/documentation/user_guides.htm
- **Xilinx Data Sheets:**
http://www.xilinx.com/support/documentation/data_sheets.htm

ISE Documentation

- **ISE Documents:**
http://www.xilinx.com/support/documentation/dt_ise13-4.htm
- *Command Line Tools User Guide (UG628):*
http://www.xilinx.com/support/documentation/sw_manuals/xilinx13_4/devref.pdf
- *Constraints Guide (UG625):*
http://www.xilinx.com/support/documentation/sw_manuals/xilinx13_4/cgd.pdf
- *Timing Closure User Guide (UG612):*
http://www.xilinx.com/support/documentation/sw_manuals/xilinx13_4/ug612.pdf
- *Xilinx Synthesis and Simulation Design Guide (UG626):*
http://www.xilinx.com/support/documentation/sw_manuals/xilinx13_4/sim.pdf
- *XST User Guide for Virtex®-4, Virtex-5, Spartan®-3, and Newer CPLD Devices (UG627):*
http://www.xilinx.com/support/documentation/sw_manuals/xilinx13_4/xst.pdf
- *XST User Guide for Virtex-6, Spartan-6, and 7 Series Devices (UG687):*
http://www.xilinx.com/support/documentation/sw_manuals/xilinx13_4/xst_v6s6.pdf

PlanAhead Tool Documentation

- **PlanAhead™ Tool Documentation:**
http://www.xilinx.com/support/documentation/dt_planahead_planahead13-4.htm

- **Methodology Guides:**
 - *Floorplanning Methodology Guide* (UG633):
http://www.xilinx.com/support/documentation/sw_manuels/xilinx13_4/Floorplanning_Methodolgy_Guide.pdf
 - *Pin Planning Methodology Guide* (UG792):
http://www.xilinx.com/support/documentation/sw_manuels/xilinx13_4/ug792_pinplan.pdf
 - *PlanAhead User Guide* (UG632):
http://www.xilinx.com/support/documentation/sw_manuels/xilinx13_4/PlanAhead_UserGuide.pdf
 - *PlanAhead Tcl Command Reference Guide* (UG789):
http://www.xilinx.com/support/documentation/sw_manuels/xilinx13_4/ug789_pa_tcl_commands.pdf
- **PlanAhead Tool Tutorials:**
http://www.xilinx.com/support/documentation/dt_planahead_planahead13-4_tutorials.htm
 - *Design Analysis and Floorplanning* (UG676):
http://www.xilinx.com/support/documentation/sw_manuels/xilinx13_4/PlanAhead_Tutorial_Design_Analysis_Floorplan.pdf
 - *I/O Pin Planning* (UG674):
http://www.xilinx.com/support/documentation/sw_manuels/xilinx13_4/PlanAhead_Tutorial_IO_Pin_Planning.pdf
 - *Leveraging Design Preservation for Predictable Results* (UG747):
http://www.xilinx.com/support/documentation/sw_manuels/xilinx13_4/PlanAhead_Tutorial_Design_Preservation.pdf