

Introduction

The XPS Universal Asynchronous Receiver Transmitter (UART) Lite Interface connects to the PLB (Processor Local Bus) and provides the controller interface for asynchronous serial data transfer. This soft IP core is designed to interface with the PLBV46.

Features

- PLB interface is based on PLB v4.6 specification
- Supports 8-bit bus interfaces
- One transmit and one receive channel (full duplex)
- 16-character Transmit FIFO and 16-character Receive FIFO
- Configurable number of data bits in a character (5-8)
- Configurable parity bit (odd or even)
- Configurable baud rate

LogiCORE™ IP Facts	
Core Specifics	
Supported Device Family	Spartan®-3A/3A DSP, Spartan-3, Spartan-3E, Automotive Spartan 3/3E/3A/3A DSP, Spartan-6, Virtex®-4 /4Q/4QV, Virtex-5/5FX, Virtex-6/6CX
Resources Used	See Table 9 , Table 11 , Table 12 , Table 13 , and Table 14
Special Features	N/A
Provided with Core	
Documentation	Product Specification
Design File Formats	VHDL
Constraints File	N/A
Verification	N/A
Instantiation Template	N/Ar
Additional Items	N/A
Design Tool Requirements	
Xilinx Implementation Tools	ISE® 11.4 or later
Verification	ModelSim PE/SE 6.4b or later
Simulation	ModelSim PE/SE 6.4b or later
Synthesis	XST
Support	
Provided by Xilinx, Inc.	

Functional Description

The XPS UART Lite performs parallel to serial conversion on characters received through PLB and serial to parallel conversion on characters received from a serial peripheral.

The XPS UART Lite is capable of transmitting and receiving 8, 7, 6 or 5 bit characters, with 1 stop bit and odd, even or no parity. The XPS UART Lite can transmit and receive independently.

The device can be configured and its status can be monitored via the internal register set. The XPS UART Lite generates an interrupt when data is present in the Receive FIFO or when the Transmit FIFO becomes empty. This interrupt can be masked by using interrupt enable/disable signal.

The device contains a 16-bit programmable baud rate generator and independent 16 word Transmit and Receive FIFOs.

The XPS UART Lite modules are shown in the top-level block diagram in [Figure 1](#).

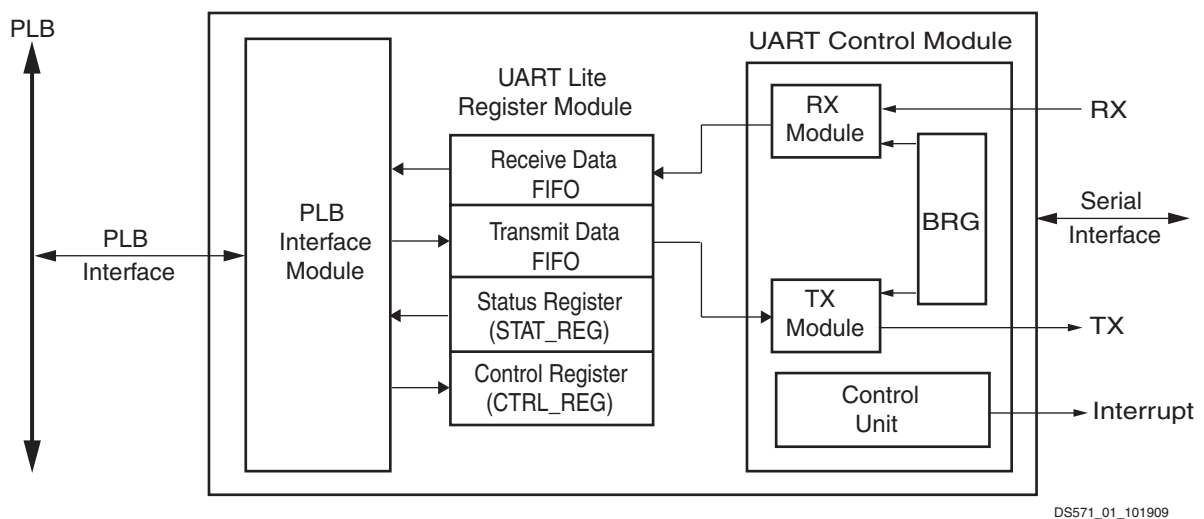

Figure 1: Block Diagram of XPS UART Lite

The XPS UART Lite modules are described in the sections below.

PLB Interface Module: The PLB Interface Module provides the interface to the PLB and implements PLB protocol logic. PLB Interface Module is a bi-directional interface between a user IP core and the PLB bus standard. To simplify the process of attaching a XPS UART Lite to the PLB, the core make use of a portable, pre-designed bus interface called PLB Interface Module, that takes care of the bus interface signals, bus protocols, and other interfaces.

UART Lite Register Module: The Register Module includes all memory mapped registers (as shown in [Figure 1](#)). It interfaces to the PLB through the PLB Interface Module. It consists of an 8-bit status register, an 8-bit control register and a pair of 8-bit Transmit/Receive FIFOs. All registers are accessed directly from the PLB using the PLB Interface Module.

UART Control Module: The UART Control Module consists of RX module, a TX module, a parameterized baud rate generator (BRG) and a Control Unit. It incorporates the state machine for initialization and start & stop bit control logic.

Interrupts

If interrupts are enabled, an interrupt is generated when one of the following conditions is true:

1. When there exists any valid character in the Receive FIFO
2. When the Transmit FIFO goes from not empty to empty, such as when the last character in the Transmit FIFO is transmitted

XPS UART Lite I/O Signals

The XPS UART Lite I/O signals are listed and described in [Table 1](#).

Table 1: XPS UART Lite I/O Signal Description

Port	Signal Name	Interface	I/O	Initial State	Description
System Signals					
P1	SPLB_Clk	System	I	-	PLB clock
P2	SPLB_Rst	System	I	-	PLB reset, active high
PLB Interface Signals					
P3	PLB_ABus[0 : 31]	PLB	I	-	PLB address bus
P4	PLB_PAVAlid	PLB	I	-	PLB primary address valid
P5	PLB_masterID[0 : C_SPLB_MID_WIDTH - 1]	PLB	I	-	PLB current master identifier
P6	PLB_RNW	PLB	I	-	PLB read not write
P7	PLB_BE[0 : (C_SPLB_DWIDTH/8) - 1]	PLB	I	-	PLB byte enables
P8	PLB_size[0 : 3]	PLB	I	-	PLB size of requested transfer
P9	PLB_type[0 : 2]	PLB	I	-	PLB transfer type
P10	PLB_wrDBus[0 : C_SPLB_DWIDTH - 1]	PLB	I	-	PLB write data bus
Unused PLB Interface Signals					
P11	PLB_UABus[0 : 31]	PLB	I	-	PLB upper address bits
P12	PLB_SAVAlid	PLB	I	-	PLB secondary address valid
P13	PLB_rdPrim	PLB	I	-	PLB secondary to primary read request indicator
P14	PLB_wrPrim	PLB	I	-	PLB secondary to primary write request indicator
P15	PLB_abort	PLB	I	-	PLB abort bus request
P16	PLB_busLock	PLB	I	-	PLB bus lock
P17	PLB_MSize[0 : 1]	PLB	I	-	PLB data bus width indicator
P18	PLB_lockErr	PLB	I	-	PLB lock error
P19	PLB_wrBurst	PLB	I	-	PLB burst write transfer
P20	PLB_rdBurst	PLB	I	-	PLB burst read transfer
P21	PLB_wrPendReq	PLB	I	-	PLB pending bus write request
P22	PLB_rdPendReq	PLB	I	-	PLB pending bus read request

Table 1: XPS UART Lite I/O Signal Description (Cont'd)

Port	Signal Name	Interface	I/O	Initial State	Description
P23	PLB_wrPendPri[0 : 1]	PLB	I	-	PLB pending write request priority
P24	PLB_rdPendPri[0 : 1]	PLB	I	-	PLB pending read request priority
P25	PLB_reqPri[0 : 1]	PLB	I	-	PLB current request priority
P26	PLB_TAttribute[0 : 15]	PLB	I	-	PLB transfer attribute
PLB Slave Interface Signals					
P27	SI_addrAck	PLB	O	0	Slave address acknowledge
P28	SI_SSize[0 : 1]	PLB	O	0	Slave data bus size
P29	SI_wait	PLB	O	0	Slave wait
P30	SI_rearbitrate	PLB	O	0	Slave bus rearbitrate
P31	SI_wrDAck	PLB	O	0	Slave write data acknowledge
P32	SI_wrComp	PLB	O	0	Slave write transfer complete
P33	SI_rdDBus[0 : C_SPLB_DWIDTH - 1]	PLB	O	0	Slave read data bus
P34	SI_rdDAck	PLB	O	0	Slave read data acknowledge
P35	SI_rdComp	PLB	O	0	Slave read transfer complete
P36	SI_MBusy[0 : C_SPLB_NUM_MASTERS - 1]	PLB	O	0	Slave busy
P37	SI_MWrErr[0 : C_SPLB_NUM_MASTERS - 1]	PLB	O	0	Slave write error
P38	SI_MRdErr[0 : C_SPLB_NUM_MASTERS - 1]	PLB	O	0	Slave read error
Unused PLB Slave Interface Signals					
P39	SI_wrBTerm	PLB	O	0	Slave terminate write burst transfer
P40	SI_rdWdAddr[0 : 3]	PLB	O	0	Slave read word address
P41	SI_rdBTerm	PLB	O	0	Slave terminate read burst transfer
P42	SI_MIRQ[0 : C_SPLB_NUM_MASTERS - 1]	PLB	O	0	Master interrupt request
UART Lite Interface Signals					
P43	RX	UART Lite	I	-	Receive Data
P44	TX	UART Lite	O	0	Transmit Data
P45	Interrupt	UART Lite	O	0	UART Interrupt

XPS UART Lite Design Parameters

To allow the user to obtain a XPS UART Lite that is uniquely tailored for the system, certain features can be parameterized in the XPS UART Lite design. This allows the user to configure a design that utilizes

the resources required by the system only and that operates with the best possible performance. The features that can be parameterized in the XPS UART Lite design are as shown in [Table 2](#).

Table 2: XPS UART Lite Design Parameters

Generic	Feature/Description	Parameter Name	Allowable Values	Default Value	VHDL Type
System Parameter					
G1	Target FPGA family	C_FAMILY	spartan3, spartan3e, spartan3a, spartan3adsp, aspartan3, aspartan3e, aspartan3a, aspartan3adsp, spartan6, virtex4, qvirtex4, qvirtex4, virtex5, virtex5fx, virtex6, virtex6cx		string
G2	System clock frequency (in Hz) driving the UART Lite peripheral	C_SPLB_CLK_FREQ_HZ	integer (ex. 100000000)	100_000_000	Integer
PLB Parameters					
G3	PLB Base Address	C_BASEADDR	Valid Address ⁽¹⁾	None ⁽³⁾	std_logic_vector
G4	PLB High Address	C_HIGHADDR	Valid Address ⁽²⁾	None ⁽³⁾	std_logic_vector
G5	PLB least significant address bus width	C_SPLB_AWIDTH	32	32	integer
G6	PLB data width	C_SPLB_DWIDTH	32, 64, 128	32	integer
G7	Selects point-to-point or shared bus topology	C_SPLB_P2P	0 = Shared Bus Topology 1 = Point-to-Point Bus Topology ⁽⁴⁾	0	integer
G8	PLB Master ID Bus Width	C_SPLB_MID_WIDTH	log ₂ (C_SPLB_NUM_MASTERS) with a minimum value of 1	1	integer
G9	Number of PLB Masters	C_SPLB_NUM_MASTERS	1 - 16	1	integer
G10	Support Bursts	C_SPLB_SUPPORT_BURSTS	0	0	integer
G11	Width of the Slave Data Bus	C_SPLB_NATIVE_DWIDTH	32	32	integer
UART Lite Parameters					
G12	Baud rate of the UART Lite in bits per second	C_BAUDRATE	integer (ex. 128000)	9600 ⁽⁵⁾	Integer
G13	The number of data bits in the serial frame	C_DATA_BITS	5 - 8	8	Integer
G14	Determines whether parity is used or not	C_USE_PARITY	0 = Do not use parity 1 = Use parity	1	Integer

Table 2: XPS UART Lite Design Parameters (Cont'd)

Generic	Feature/Description	Parameter Name	Allowable Values	Default Value	VHDL Type
G15	If parity is used, determines whether parity is odd or even	C_ODD_PARITY	0 = Even parity 1 = Odd parity	1	Integer

- The user must set the values. The C_BASEADDR must be a multiple of the range, where the range is C_HIGHADDR - C_BASEADDR + 1.
- C_HIGHADDR - C_BASEADDR must be a power of 2 greater than equal to C_BASEADDR + 0xF.
- No default value will be specified to insure that the actual value is set, i.e., if the value is not set, a compiler error will be generated.
- Value of '1' is not supported in this core.
- With a baud rate of 115200, the sample clock is $16 * 115200 = 1.8432$ MHz. With the System clock C_SPLB_CLK_FREQ_HZ running at 10 MHz, the integer ratio for driving the sample clock is 5 (rounding of $\lceil 10/1.8432 \rceil$). The UART Lite would then divide the System clock by 5 resulting in 2 MHz for the sample clock. The baud rate error is $(1.8432 - 2) / 1.8432 \Rightarrow -8.5\%$ which is outside the tolerance for most UARTs. The issue is that the higher the baud rate and the lower the C_SPLB_CLK_FREQ_HZ, the greater the error in the generated baud rate of the UART Lite. Specifications for the baud rate error state that, within 5% of the requested rate is considered acceptable.

Allowable Parameter Combinations

The address range specified by C_BASEADDR and C_HIGHADDR must be a power of 2, and must be at least 0xF.

For example, if C_BASEADDR = 0xE0000000, C_HIGHADDR must be at least = 0xE000000F.

XPS UART Lite Parameter - Port Dependencies

The dependencies between the XPS UART Lite core design parameters and I/O signals are described in Table 3. In addition, when certain features are parameterized out of the design, the related logic will no longer be a part of the design. The unused input signals and related output signals are set to a specified value.

Table 3: XPS UART Lite Parameter-Port Dependencies

Generic or Port	Name	Affects	Depends	Relationship Description
Design Parameters				
G6	C_SPLB_DWIDTH	P7, P10, P33	-	Affects the number of bits in data bus
G8	C_SPLB_MID_WIDTH	P5	G9	This value is calculated as: $\log_2(\text{C_SPLB_NUM_MASTERS})$ with a minimum value of 1
G9	C_SPLB_NUM_MASTERS	P36, P37, P38, P42	-	Affects the number of PLB masters
I/O Signals				
P5	PLB_masterID[0 : C_SPLB_MID_WIDTH - 1]	-	G8	Width of the PLB_masterID varies according to C_SPLB_MID_WIDTH
P7	PLB_BE[0 : (C_SPLB_DWIDTH/8) - 1]	-	G6	Width of the PLB_BE varies according to C_SPLB_DWIDTH
P10	PLB_wrDBus[0 : C_SPLB_DWIDTH - 1]	-	G6	Width of the PLB_wrDBus varies according to C_SPLB_DWIDTH
P33	SI_rdDBus[0 : C_SPLB_DWIDTH - 1]	-	G6	Width of the SI_rdDBus varies according to C_SPLB_DWIDTH

Table 3: XPS UART Lite Parameter-Port Dependencies (Cont'd)

Generic or Port	Name	Affects	Depends	Relationship Description
P36	SI_MBusy[0 : C_SPLB_NUM_MASTERS - 1]	-	G9	Width of the SI_MBusy varies according to C_SPLB_NUM_MASTERS
P37	SI_MWrErr[0 : C_SPLB_NUM_MASTERS - 1]	-	G9	Width of the SI_MWrErr varies according to C_SPLB_NUM_MASTERS
P38	SI_MRdErr[0 : C_SPLB_NUM_MASTERS - 1]	-	G9	Width of the SI_MRdErr varies according to C_SPLB_NUM_MASTERS
P42	SI_MIRQ[0 : C_SPLB_NUM_MASTERS - 1]	-	G9	Width of the SI_MIRQ varies according to C_SPLB_NUM_MASTERS

XPS UART Lite Register Descriptions

Table 4 shows all the XPS UART Lite registers and their addresses.

Table 4: XPS UART Lite Registers

Base Address + Offset (hex)	Register Name	Access Type	Default Value (hex)	Description
C_BASEADDR + 0x0	Rx FIFO	Read (1)	0x0	Receive Data FIFO
C_BASEADDR + 0x4	Tx FIFO	Write (2)	0x0	Transmit Data FIFO
C_BASEADDR + 0x8	STAT_REG	Read (1)	0x4	UART Lite Status Register
C_BASEADDR + 0xC	CTRL_REG	Write (2)	0x0	UART Lite Control Register

1. Writing of a read only register has no effect.
2. Reading of a write only register returns zero.

Receive Data FIFO

This 16 entry deep FIFO contains data to be received by XPS UART Lite. The FIFO bit definitions are shown in Table 5. Reading of this location will result in reading the current word out from the FIFO. When a read request is issued to an empty FIFO a bus error will be generated and the result is undefined. The Receive Data FIFO is a read-only register. Issuing a write request to Receive Data FIFO will do nothing but generate the write acknowledgement. Figure 2 shows the location for data on the PLB when C_DATA_BITS is set to 8.

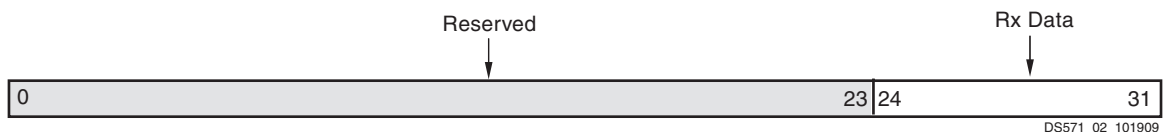

Figure 2: Receive Data FIFO (C_DATA_BITS = 8)

Table 5: Receive Data FIFO Bit Definitions

Bit(s)	Name	Core Access	Reset Value	Description
0 - [31-C_DATA_BITS]	Reserved	N/A	0	Reserved
[(31-C_DATA_BITS)+1] - 31	Rx Data	Read	0	UART Receive data

Transmit Data FIFO

This 16 entry deep FIFO contains data to be output by XPS UART Lite. The FIFO bit definitions are shown in Table 6. Data to be transmitted is written into this register. This is write only location. Issuing a read request to Transmit Data FIFO will generate the read acknowledgement with zero data. Figure 3 shows the location for data on the PLB when C_DATA_BITS is set to 8.

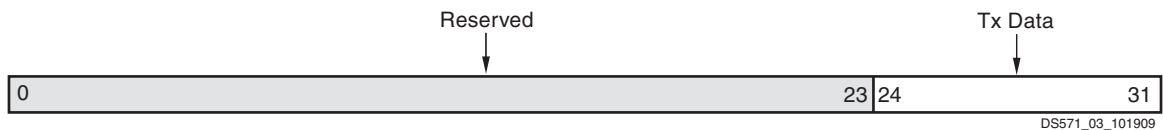

Figure 3: Transmit Data FIFO (C_DATA_BITS = 8)

Table 6: Transmit Data FIFO Bit Definitions

Bit(s)	Name	Core Access	Reset Value	Description
0 - [31-C_DATA_BITS]	Reserved	N/A	0	Reserved
[(31-C_DATA_BITS)+1] - 31	Tx Data	Write	0	UART transmit data

UART Lite Control Register (CTRL_REG)

The UART Lite Control Register contains the Enable Interrupt bit and Reset pin for Receive and Transmit Data FIFO. This is write only register. Issuing a read request to Control Register will generate the read acknowledgement with zero data. Figure 4 shows the bit assignment of the CTRL_REG. Table 7 describes this bit assignment.

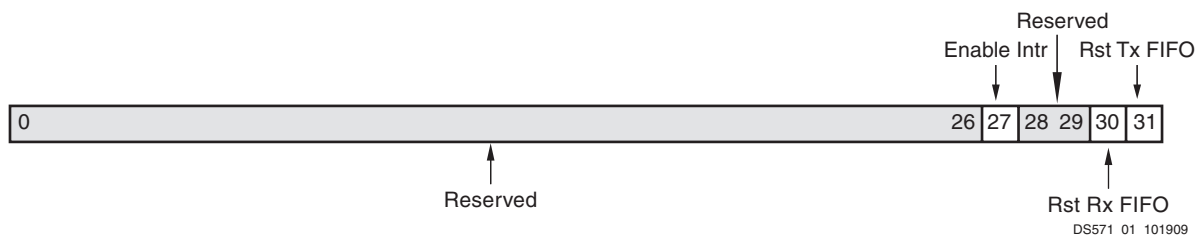

Figure 4: UART Lite Control Register

Table 7: UART Lite Control Register Bit Definitions

Bit(s)	Name	Core Access	Reset Value	Description
0 - 26	Reserved	N/A	0	Reserved
27	Enable Intr	Write	'0'	Enable Interrupt for the UART Lite '0' = Disable interrupt signal '1' = Enable interrupt signal
28 - 29	Reserved	N/A	0	Reserved
30	Rst Rx FIFO	Write	'0'	Reset/Clear the Receive FIFO Writing a '1' to this bit position clears the Receive FIFO '0' = Do nothing '1' = Clear the Receive FIFO
31	Rst Tx FIFO	Write	'0'	Reset/Clear the Transmit FIFO Writing a '1' to this bit position clears the Transmit FIFO '0' = Do nothing '1' = Clear the Transmit FIFO

UART Lite Status Register (STAT_REG)

The UART Lite Status Register contains the status of the Receive and Transmit Data FIFO, if interrupts are enabled, and if there are any errors. This is read only register. If a write request is issued to status register it will do nothing but generate write acknowledgement. Bit assignment in the STAT_REG is shown in Figure 5 and described in Table 8.

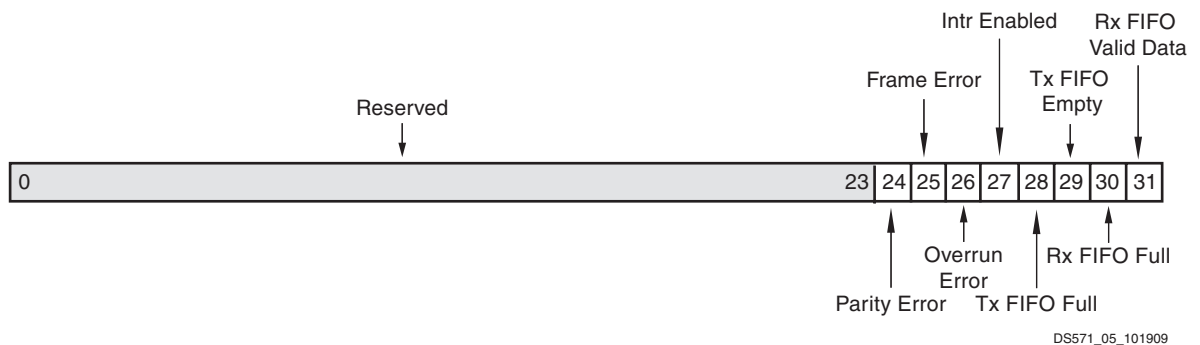

Figure 5: UART Lite Status Register

Table 8: UART Lite Status Register Bit Definitions

Bit(s)	Name	Core Access	Reset Value	Description
0 - 23	Reserved	N/A	0	Reserved
24	Parity Error	Read	'0'	Indicates that a parity error has occurred since the last time the status register was read. If the UART is configured without any parity handling, this bit will always be '0'. The received character will be written into the Receive FIFO. This bit will be cleared when the status register is read '0' = No parity error has occurred '1' = A parity error has occurred

Table 8: UART Lite Status Register Bit Definitions (Cont'd)

Bit(s)	Name	Core Access	Reset Value	Description
25	Frame Error	Read	'0'	Indicates that a frame error has occurred since the last time the status register was read. Frame Error is defined as detection of a stop bit with the value '0'. The receive character will be ignored and not written to the Receive FIFO. This bit will be cleared when the status register is read '0' = No Frame error has occurred '1' = A frame error has occurred
26	Overrun Error	Read	'0'	Indicates that an overrun error has occurred since the last time the status register was read. Overrun is when a new character has been received but the Receive FIFO is full. The received character will be ignored and not written into the Receive FIFO. This bit will be cleared when the status register is read '0' = No interrupt has occurred '1' = Interrupt has occurred
27	Intr Enabled	Read	'0'	Indicates that interrupts is enabled '0' = Interrupt is disabled '1' = Interrupt is enabled
28	Tx FIFO Full	Read	'0'	Indicates if the Transmit FIFO is full '0' = Transmit FIFO is not full '1' = Transmit FIFO is full
29	Tx FIFO Empty	Read	'1'	Indicates if the Transmit FIFO is empty '0' = Transmit FIFO is not empty '1' = Transmit FIFO is empty
30	Rx FIFO Full	Read	'0'	Indicates if the Receive FIFO is full '0' = Receive FIFO is not full '1' = Receive FIFO is full
31	Rx FIFO Valid Data	Read	'0'	Indicates if the receive FIFO has valid data '0' = Receive FIFO is empty '1' = Receive FIFO has valid data

Design Implementation

Target Technology

The target technology is an FPGA listed in the [Supported Device Family](#) field of the LogiCORE IP Facts table.

Device Utilization and Performance Benchmarks

Core Performance

Since the XPS UART Lite core will be used with other design modules in the FPGA, the utilization and timing numbers reported in this section are estimates only. When the XPS UART Lite core is combined with other designs in the system, the utilization of FPGA resources and timing of the XPS UART Lite design will vary from the results reported here.

The XPS UART Lite resource utilization for various parameter combinations measured with Virtex[®]-4 as the target device are detailed in [Table 9](#), Virtex-5 as the target device are detailed in [Table 10](#), Virtex-6 as the target device are detailed in [Table 11](#), Spartan[®]-3E as the target device are detailed in [Table 12](#) and Spartan-6 as the target device are detailed in [Table 13](#)

Table 9: Performance and Resource Utilization Benchmarks on the Virtex-4 FPGA (xc4vlx25-10-ff668)

Parameter Values (other parameters at default value)						Device Resources			Performance
C_SPLB_AWIDTH	C_SPLB_CLK_FREQ_HZ	C_BAUDRATE	C_DATA_BITS	C_USE_PARITY	C_ODD_PARITY	Slices	Slice Flip-Flops	LUTs	F _{MAX} (MHz)
32	100_000_000	19_200	5	FALSE	FALSE	92	77	122	157
32	100_000_000	19_200	6	FALSE	FALSE	93	78	126	167
32	100_000_000	19_200	7	FALSE	FALSE	96	79	128	171
32	100_000_000	19_200	8	FALSE	FALSE	97	80	130	175
32	40_000_000	38_400	8	FALSE	FALSE	97	80	130	175
32	100_000_000	19_200	6	TRUE	FALSE	101	84	133	173
32	100_000_000	19_200	7	TRUE	FALSE	101	85	134	161

Table 10: Performance and Resource Utilization Benchmarks on the Virtex-5 FPGA (xc5vix85-1-ff1153)

Parameter Values (other parameters at default value)						Device Resources			Performance
C_SPLB_AWIDTH	C_SPLB_CLK_FREQ_HZ	C_BAUDRATE	C_DATA_BITS	C_USE_PARITY	C_ODD_PARITY	Slices	Slice Flip-Flops	LUTs	f _{MAX} (MHz)
32	100_000_000	19_200	5	FALSE	FALSE	84	85	127	168
32	100_000_000	19_200	6	FALSE	FALSE	97	84	125	164
32	100_000_000	19_200	7	FALSE	FALSE	89	79	118	162
32	100_000_000	19_200	8	FALSE	FALSE	86	79	122	195
32	40_000_000	38_400	8	FALSE	FALSE	82	78	124	181
32	100_000_000	19_200	6	TRUE	FALSE	97	84	125	164
32	100_000_000	19_200	7	TRUE	FALSE	97	84	125	164

Table 11: Performance and Resource Utilization Benchmarks on the Virtex-6 FPGA (xc6vix115t-1-ft1156)

Parameter Values (other parameters at default value)						Device Resources			Performance
C_SPLB_AWIDTH	C_SPLB_CLK_FREQ_HZ	C_BAUDRATE	C_DATA_BITS	C_USE_PARITY	C_ODD_PARITY	Slices	Slice Flip-Flops	LUTs	f _{MAX} (MHz)
32	100_000_000	19_200	5	FALSE	FALSE	61	80	115	189
32	100_000_000	19_200	6	FALSE	FALSE	64	81	119	166
32	100_000_000	19_200	7	FALSE	FALSE	62	82	121	173
32	100_000_000	19_200	8	FALSE	FALSE	65	83	134	180
32	40_000_000	38_400	8	FALSE	FALSE	64	81	137	186
32	100_000_000	19_200	6	TRUE	FALSE	67	87	124	171
32	100_000_000	19_200	7	TRUE	FALSE	66	88	126	170

Table 12: Performance and Resource Utilization Benchmarks on the Spartan-3E FPGA (xc3s250e-4-ft256)

Parameter Values (other parameters at default value)						Device Resources			Performance
C_SPLB_AWIDTH	C_SPLB_CLK_FREQ_HZ	C_BAUDRATE	C_DATA_BITS	C_USE_PARITY	C_ODD_PARITY	Slices	Slice Flip-Flops	LUTs	f _{MAX} (MHz)
32	100_000_000	19_200	5	FALSE	FALSE	92	77	122	108
32	100_000_000	19_200	6	FALSE	FALSE	91	78	126	109
32	100_000_000	19_200	7	FALSE	FALSE	94	79	128	128
32	100_000_000	19_200	8	FALSE	FALSE	95	80	130	115
32	40_000_000	38_400	8	FALSE	FALSE	96	78	127	110
32	100_000_000	19_200	6	TRUE	FALSE	92	77	122	108
32	100_000_000	19_200	7	TRUE	FALSE	91	78	126	109

Table 13: Performance and Resource Utilization Benchmarks on the Spartan-6 FPGA (xc6slx16-2-csg324)

Parameter Values (other parameters at default value)						Device Resources			Performance
C_SPLB_AWIDTH	C_SPLB_CLK_FREQ_HZ	C_BAUDRATE	C_DATA_BITS	C_USE_PARITY	C_ODD_PARITY	Slices	Slice Flip-Flops	LUTs	F _{MAX} (MHz)
32	100_000_000	19_200	5	FALSE	FALSE	67	80	119	105
32	100_000_000	19_200	6	FALSE	FALSE	79	81	123	100
32	100_000_000	19_200	7	FALSE	FALSE	61	82	121	103
32	100_000_000	19_200	8	FALSE	FALSE	74	83	124	103
32	40_000_000	38_400	8	FALSE	FALSE	63	81	114	103
32	100_000_000	19_200	6	TRUE	FALSE	76	87	129	102
32	100_000_000	19_200	7	TRUE	FALSE	76	88	131	110

System Performance

To measure the system performance (Fmax) of this core, this core was added to a Virtex-4 system, a Virtex-5 system, and a Spartan-3A system as the Device Under Test (DUT) as shown in [Figure 6](#), [Figure 7](#), and [Figure 8](#).

Because the XPS UART Lite core will be used with other design modules in the FPGA, the utilization and timing numbers reported in this section are estimates only. When this core is combined with other designs in the system, the utilization of FPGA resources and timing of the design will vary from the results reported here.

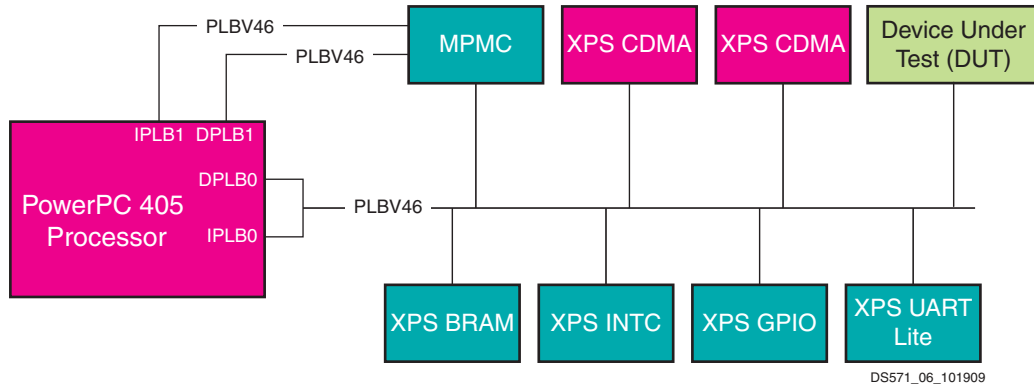

Figure 6: Virtex-4 FX System with the XPS UART Lite Device as the DUT

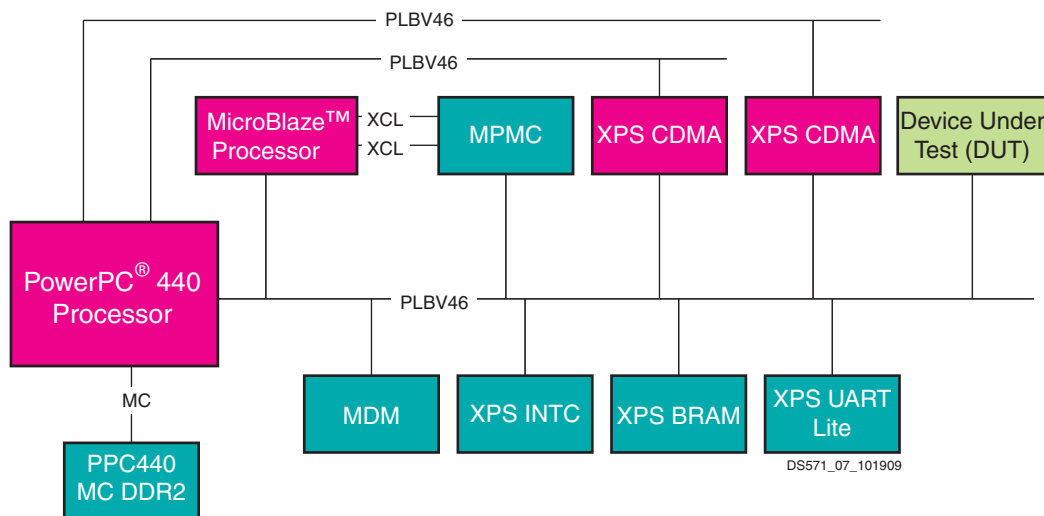

Figure 7: Virtex-5 FX System with the XPS UART Lite Device as the DUT

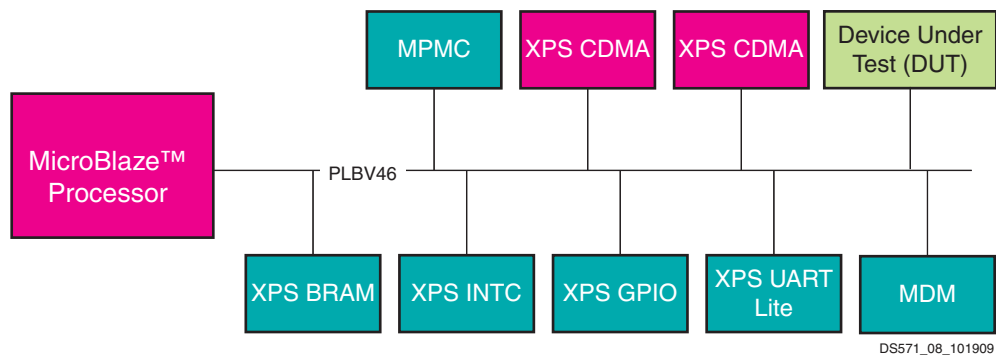

Figure 8: Spartan-3A System with the XPS UART Lite Device as the DUT

The target FPGA was then filled with logic to drive the LUT and BRAM utilization to approximately 70% and the I/O utilization to approximately 80%. Using the default tool options and the slowest speed grade for the target FPGA, the resulting target F_{MAX} numbers are shown in Table 14.

Table 14: XPS UART Lite System Performance

Target FPGA	Target F_{MAX} (MHz)
S3A700 -4	90
V4FX60 -10	100
V5LXT50 -1	120

The target F_{MAX} is influenced by the exact system and is provided for guidance. It is not a guaranteed value across all systems.

Support

Xilinx provides technical support for this LogiCORE product when used as described in the product documentation. Xilinx cannot guarantee timing, functionality, or support of product if implemented in devices that are not defined in the documentation, if customized beyond that allowed in the product documentation, or if changes are made to any section of the design labeled *DO NOT MODIFY*.

Reference Documents

1. IBM CoreConnect 128-Bit Processor Local Bus, Architectural Specification (v4.6).

Revision History

The following table shows the revision history for this document:

Date	Version	Description of Revisions
4/18/07	1.0	Initial Xilinx release.
4/20/07	1.1	Added SP-3 support.
9/26/07	1.2	Added FMax Margin <RD Red>System Performance section.
11/27/07	1.3	Added SP3A DSP to supported devices listing.
1/14/08	1.4	Added Virtex-II Pro support.
4/21/08	1.5	Added Automotive Spartan-3E, Automotive Spartan-3A, Automotive Spartan-3, and Automotive Spartan-3A DSP support.
7/18/08	1.6	Added QPro Virtex-4 Hi-Rel and QPro Virtex-4 Rad Tolerant FPGA support.
9/20/08	1.7	Updated to version v1.01a. Removed Virtex-II Pro support. Modified Interrupts and Register description sections. Modified default value of C_BAUDRATE to 9600 in Table2.
4/24/09	1.8	Replaced references to supported device families and tool name(s) with hyperlink to PDF file.
4/29/09	1.9	Updated figures in system performances section.
7/17/09	2.0	Modified Functional Description section and added Virtex-6, Spartan-6 support.
12/2/09	2.1	Listed supported devices families in LogiCORE Table; updated images, converted to new DS template.

Notice of Disclaimer

Xilinx is providing this product documentation, hereinafter "Information," to you "AS IS" with no warranty of any kind, express or implied. Xilinx makes no representation that the Information, or any particular implementation thereof, is free from any claims of infringement. You are responsible for obtaining any rights you may require for any implementation based on the Information. All specifications are subject to change without notice. XILINX EXPRESSLY DISCLAIMS ANY WARRANTY WHATSOEVER WITH RESPECT TO THE ADEQUACY OF THE INFORMATION OR ANY IMPLEMENTATION BASED THEREON, INCLUDING BUT NOT LIMITED TO ANY WARRANTIES OR REPRESENTATIONS THAT THIS IMPLEMENTATION IS FREE FROM CLAIMS OF INFRINGEMENT AND ANY IMPLIED WARRANTIES OF MERCHANTABILITY OR FITNESS FOR A PARTICULAR PURPOSE. Except as stated herein, none of the Information may be copied, reproduced, distributed, republished, downloaded, displayed, posted, or transmitted in any form or by any means including, but not limited to, electronic, mechanical, photocopying, recording, or otherwise, without the prior written consent of Xilinx.